

# RADIO NEWS

JANUARY  
1946  
35c  
In Canada 40c





**ONLY MECK HAS THE COURAGE TO TELL THIS STORY**



**MONTH  
AFTER  
MONTH**



**Surveys show—**

That approximately 64% of the prospects for new radio sets in your community—have not yet decided where they will buy their postwar radios.

There is still time for independent radio and electrical dealers to keep the radio business where it belongs. Tie in now with the Meck program—the only consumer advertising program devoted to selling the public on the DEALER.

Ask about the Meck Preferential Dealer Plan.

*John Meck*

*Buy Your New Radio  
from Your Radio Dealer  
— HE KNOWS THE INSIDE STORY!*

**FIRST  
WIN THE WAR  
BUY WAR BONDS**



You will select and determine the style you want in your new postwar radio—but it will pay you to depend on my experience as a radio specialist for quality performance, freedom from trouble. That specialist is your local radio dealer.

My years of experience and technical knowledge enable me to choose the best postwar models with the most desirable improvements inside.

That's why many of our dealers have already chosen Meck Radios. They offer you outstanding engineering advances, as well as a reputation for quality firmly established through years of building world-famous electronic products.

Years for good listening.  
*Your Radio Dealer.*  
**MECK RADIOS**  
JOHN MECK INDUSTRIES, Inc., PLYMOUTH, INDIANA

**JOHN MECK INDUSTRIES, INC., PLYMOUTH, INDIANA**



J. E. SMITH,  
PRESIDENT  
National Radio  
Institute  
31st Year of  
Training Men  
for Success  
in Radio



# WIL TRAIN YOU O S AR

## A SPARE TIME OR FULL TIME

# RADIO SERVICE BUSINESS

# WITHOUT CAPITAL

### You Build These and Many Other Radio Circuits with 6 Kits of Parts I Supply

By the time you've conducted 60 sets of Experiments with Radio Parts I supply, made hundreds of measurements and adjustments, you'll have valuable PRACTICAL Radio experience for a good full or part-time Radio job!

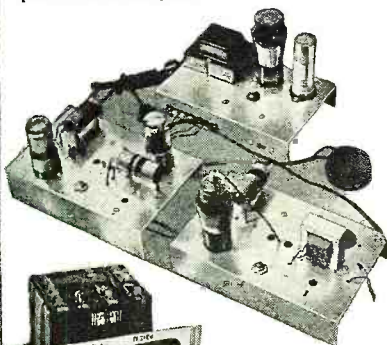

You build the SUPERHETERODYNE CIRCUIT above containing a preselector oscillator-mixer-first detector, I.F. stage, diode-detector-a.v.c. stage and audio stage. It will bring in local and distant stations. Get the thrill of learning at home evenings in spare time while you put the set through fascinating tests!

You build MEASURING INSTRUMENT above early in Course, useful for Radio work to pick up EXTRA spare time money. It is a vacuum tube multimeter, measures A.C., D.C., R.F. volts, D.C. currents, resistance, receiver output.

Building the A. M. SIGNAL GENERATOR at right will give you valuable experience. Provides amplitude-modulated signals for test and experimental purposes.

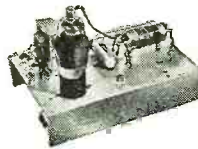

The men at the right are just a few of many I have trained, at home in their spare time, to be Radio Technicians. They are now operating their own successful spare time or full time Radio businesses. Hundreds of other men I trained are holding good jobs in practically every branch of Radio, as Radio Technicians or Operators. Doesn't this PROVE that my "50-50 Method" of training can give you, in your spare time at home, BOTH a thorough knowledge of Radio principles and the PRACTICAL experience you need to help you make more money in the fast-growing Radio industry?

Let me send you facts about rich opportunities in the busy Radio field. See how knowing Radio can give you security, a prosperous future... lead to jobs coming in Television and Electronics. Send the coupon NOW for FREE 64-page illustrated book, "Win Rich Rewards in Radio." Read how N.R.I. trains you at home in spare time. Read how you practice building, testing, repairing Radios with SIX BIG KITS of Radio parts I send as part of your Course.

**Future for Trained Men Is Bright in Radio, Television, Electronics**  
The Radio Repair business is booming NOW. There is good money fixing Radios in your spare time or own full time business. And trained Radio Technicians also find wide-open opportunities in Police, Aviation and Marine Radio, in Broadcasting, Radio Manufacturing, Public Address work, etc. Send for free book which pictures your present and future opportunities.

Think of the boom coming now that new Radios can be made! Think of the backlog of business built up in all branches of Radio! And think of even greater opportunities when Television and Electronics are available to the public! Use only a few hours of your spare time each week to get into Radio NOW. You may never again see the time when it will be so easy and profitable to get started. Mail coupon for complete information.

**Many Beginners Soon Make \$5, \$10 a Week EXTRA in Spare Time**  
The day you enroll I start sending EXTRA MONEY JOB SHEETS to help you make EXTRA money fixing Radios in spare time while learning. You LEARN Radio principles from my easy-to-grasp Lessons - PRACTICE what you learn by building real Radio Circuits with the six kits of Radio parts I send - USE your knowledge to make EXTRA money while getting ready for a good full time Radio job.

**Find Out What N.R.I. Can Do for YOU**  
MAIL THE COUPON for your FREE copy of my 64-page book. It's packed with facts about opportunities for you. Read the details about my Course. See the fascinating jobs Radio offers. See how you can train at home. Read letters from men I trained, telling what they are doing, earning. No obligation. Just MAIL COUPON in an envelope or paste it on a penny postal. J. E. Smith, President, Dept. 6AR, National Radio Institute, Pioneer Home Study Radio School, Washington 9, D. C.

I Trained These Men

SPARE TIME RADIO BUSINESS



"I have a spare time Radio and been very profitable, due to the efficient training I received from your Course. Last year I averaged over \$50 a month."  
-FRED H. GRIFFITE, Route 3, Newville, Pa.

"I am doing radio work in my spare time, and find it a profitable hobby. My extra earnings run about \$10 a week. I certainly am glad I took your N.R.I. Course." - FERDINAND ZIRBEL, Chaseley, North Dakota.



"About six months after I enrolled I am a farmer and just work on radios evenings and stormy days. That brought me a profit of \$600 in the last year."  
-BENNIE L. ARENDS, RFD 2, Alexander, Iowa.

I Trained These Men

FULL TIME RADIO BUSINESS



"Not long ago I was working 16 hours a day in a filling station at \$10 a week. Now I have my own radio business and average over \$60 a week. The N.R.I. course is fine."  
-ALBERT C. CHRISTENSEN, 1116-10th Avenue, Sidney, Neb.

"I am now operating a radio shop for myself and own all my equipment. There are none to sell, but I average \$250 a month."  
-J. M. SCRIVENER JR., Aberdeen, Miss.



"Am making over \$50 a week profit from my own shop. Have another N.R.I. graduate working for me. I like to hire N.R.I. men because they know radio."  
-NORMAN MILLER, Hebron, Neb.

## SAMPLE LESSON FREE

I will send you a FREE Lesson, "Getting Acquainted with Receiver Servicing," to show you how practical it is to train for Radio at home in spare time. It's a valuable lesson. Study it—keep it—use it—without obligation! Tells how Superheterodyne Circuits work, gives hints on Receiver Servicing, Locating Defects, Repair of Loudspeaker, I.F. Transformer, Gang Tuning, Condenser, etc. 31 illustrations.



My Radio Course Includes  
**TELEVISION • ELECTRONICS  
FREQUENCY MODULATION**

## GOOD FOR BOTH 64 PAGE BOOK SAMPLE LESSON FREE

J. E. SMITH, President, Dept. 6AR  
National Radio Institute, Washington 9, D. C.

Without obligating me, mail your Sample Lesson and 64-page book FREE. I am particularly interested in the branch of Radio checked below. (No salesman will call. Please write plainly.)

- |   |  |
|---|--|
| <input type="checkbox"/> Radio Service Business of My Own                   | <input type="checkbox"/> Aviation Radio                  |
| <input type="checkbox"/> Service Technicians for Radio Stores and Factories | <input type="checkbox"/> Operating Broadcasting Stations |
| <input type="checkbox"/> Spare Time Radio Servicing                         | <input type="checkbox"/> Army, Navy Radio Jobs           |
| <input type="checkbox"/> Government Civilian Radio                          | <input type="checkbox"/> Operating Police Radio Stations |
|   | <input type="checkbox"/> Operating Ship and Harbor Radio |

(If you have not decided which branch you prefer—mail coupon for facts to help you decide.)

Name..... Age.....  
Address.....  
City..... Zone..... State..... 4PR

HOW TO TRAIN AT HOME AND Win Rich Rewards in Radio





**AMATEUR**

Introduction to U.H.F. Frequency Measurements.....*Guy Dexter* 32  
 135 to 500 Mc. Signal Generator.....*John Wonsowicz, W9DUT, and Herbert S. Brier, W9EGQ* 35  
 Unusual Transmitter for 28-54 Mc.....*Rufus P. Turner, W1AY* 40  
 International Short-Wave.....*Kenneth R. Boord* 43  
 R.F. Chokes at U.H.F.....*W. J. Stolze* 54  
 A Simple Remote Tuning Device for Receivers..*Capt. E. L. Hannum, Jr.* 76

**COMMUNICATIONS**

The Army's Radio Relay Equipment.....*Andrew R. Boone* 25  
 FM in Canada.....*Dorothy Holloway* 30  
 From Studio to Master Control.....*Henry J. Seitz* 47  
 Listening to the World.....*Christopher Cross* 64

**SERVICE**

Resistance Measurements.....*Shepherd Litt, W2LCC* 44  
 R.F.-I.F.-A.F. Signal Tracer.....*Vincent Cavaleri* 50  
 Television Sweep Oscillators.....*Edward M. Noll* 52  
 Practical Radio Course.....*Alfred A. Gbirardi* 57  
 Television for Urbanized Areas.....*George Duvall* 88

**GENERAL**

For the Record..... 8  
 Spot Radio News..... 12  
 Radio Operated Airplane.....*S. R. Winters* 29  
 Improved Sound Reproducer.....*Christian A. Volf* 38  
 QTC.....*Carl Coleman* 56  
 What's New in Radio..... 68  
 The Signal Corps On—and In—the Air..... 94  
 Letters from Our Readers..... 118  
 Manufacturers' Literature..... 128  
 Within the Industry..... 136  
 Index to Volumes 33-34..... 142

**EDITORIAL**

- OLIVER READ, W9ETI**  
*Editor*
- WM. A. STOCKLIN**  
*Ass't to the Editor*
- JOE MARTY, JR.**  
*Associate Editor*
- HAROLD S. RENNE**  
*Technical Editor*
- RAY FRANK, W9JU**  
*Amateur Radio*
- FRED HAMLIN**  
*Washington Editor*
- E. H. SEHNERT**  
*Chief Draftsman*
- R. S. KUPJACK**  
*Staff Artist*

**ADVERTISING**

- L. L. OSTEN**  
*Advertising Mgr.*
- JOHN RONAN, JR.**  
*Midwest Adv. Mgr.*
- WM. L. PINNEY**  
*Western Adv. Mgr.*



Cover Photo  
 By FRANK ROSS

COPYRIGHT, 1946 ZIFF-DAVIS PUBLISHING COMPANY  
 185 N. Wabash Ave., Chicago 1, Ill.

BRANCH OFFICES: NEW YORK, WASHINGTON, LOS ANGELES, TORONTO



- |  |   |   |
|--|---|---|
| <b>WILLIAM B. ZIFF</b><br><i>Publisher</i>     | <b>C. R. TIGHE</b><br><i>Ass't to the Publisher</i> | <b>GEORGE BERNER</b><br><i>Advertising Director</i>   |
| <b>B. G. DAVIS</b><br><i>General Manager</i>   | <b>H. G. STRONG</b><br><i>Circulation Director</i>  | <b>H. J. MORGANROTH</b><br><i>Production Director</i> |
| <b>HERMAN R. BOLLIN</b><br><i>Art Director</i> |   |   |

Infra-red drying ovens used to dry component parts of a radio chassis after tropicalization treatment. Conveyor belt moves chassis assemblies through the oven at a rate equal to the drying time of the lacquer. Photograph taken at the Farnsworth Television and Radio Corp.'s plant at Marion, Indiana.

RADIO NEWS is published monthly by the Ziff-Davis Publishing Company, 185 N. Wabash Ave., Chicago 1, Ill. Subscription Rates: in U. S. \$3.00 (12 issues), single copies 35 cents; in Mexico, South and Central America, and U. S. Possessions, \$3.00 (12 issues); in Canada \$3.50 (12 issues), single copies 40 cents; in British Empire, \$4.00 (12 issues); all other foreign countries \$4.00 (12 issues). Subscribers should allow at least 2 weeks for change of address. All communications about subscriptions should be addressed to: Director of Circulation, 185 N. Wabash Ave., Chicago 1, Ill. Entered as second class matter March 9, 1938, at the Post Office, Chicago, Illinois, under the Act of March 3, 1879. Entered as second class matter at the Post Office Dept., Ottawa, Canada. Contributors should retain a copy of contributions and include return postage. Contributions will be handled with reasonable care but this magazine assumes no responsibility for their safety. Accepted material is subject to whatever revisions and by-line changes that are necessary. Payment, made at our current rates, covers all authors', contributors', or contestants' rights, title, and interest in and to accepted material, including photos and drawings.

Other Ziff-Davis Publications: Radio & Appliances, Radio-Electronic Engineering, Plastics, Flying, Industrial Aviation, Popular Photography



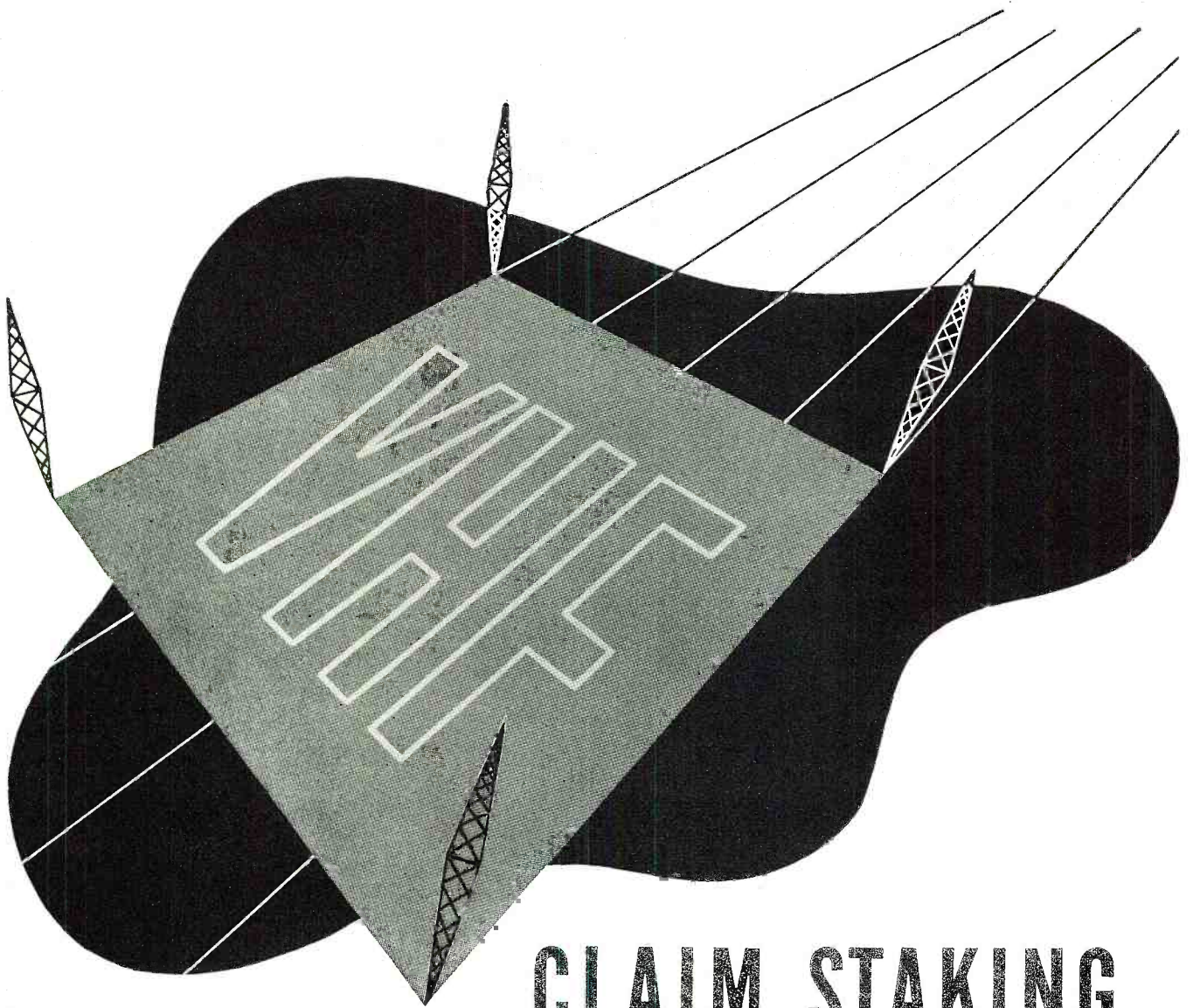

# CLAIM STAKING

## Hallicrafters and Very High Frequency

Based on the facts in the case, Hallicrafters can stake out a very strong claim to leadership in the very high frequency field. The facts include such things as the Model S-37, FM-AM receiver for very high frequency work. The Model S-37 operates from 130 to 210 Mc.—the highest frequency range of any general coverage commercial type receiver.

Hallicrafters further supports its claim to domination in the high frequency field with the Model S-36A, FM-AM-CW receiver. The 36A operates from 27.8 to 143 Mc., covers both old and new FM bands and is the only commercially built receiver covering this range.

*Further developments in this direction can soon be revealed—adding further support to Hallicrafters claim to continued supremacy in the high frequency field.*

HALLICRAFTERS NEW \$600,000 HOME NOW UNDER CONSTRUCTION.



# hallicrafters RADIO

January, 1946



THE HALLICRAFTERS CO., MANUFACTURERS OF RADIO AND ELECTRONIC EQUIPMENT • CHICAGO 16, U. S. A.

COPYRIGHT 1945 THE HALLICRAFTERS CO.



No. 1 IN A SERIES OUTLINING FADA'S COMPLETE DEALER PROMOTION PLAN

# POINT OF SALE

*dealer helps*

**THAT SELL!  
AS THEY TELL!**



Our dealer help plan is so thorough and so extensive that it will gladden the heart of every Fada dealer. From national advertising to point-of-sale promotion, we haven't overlooked a thing.

For example, here are two beautiful neon-light signs available to our authorized dealers. These signs add drama to your display rooms; they attract crowds of new customers to your place. Yes, they build radio sales — Fada sales — because they emphasize the point that Fada radios have been "famous since the very beginnings of radio reception". Both are signs that "sell as they tell".

Write for detailed information on Fada dealer franchise.

YOU CAN ALWAYS DEPEND ON

# FADA Radio

OF THE FUTURE

*Famous Since Broadcasting Began!*



FADA RADIO AND ELECTRIC COMPANY, INC., LONG ISLAND CITY, N. Y.

RADIO NEWS



# I'LL SHOW YOU HOW TO SUCCEED IN RADIO

Here's the right training for Big Post-War Pay!



F. L. Sprayberry, one of the country's foremost Radio Teachers.



A RADIO SERVICE BUSINESS OF YOUR OWN

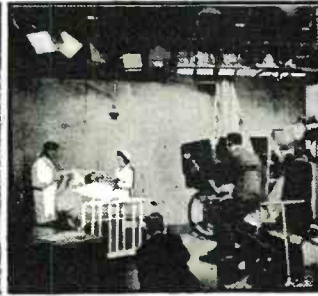

A GOOD JOB IN RADIO & TELEVISION BROADCASTING

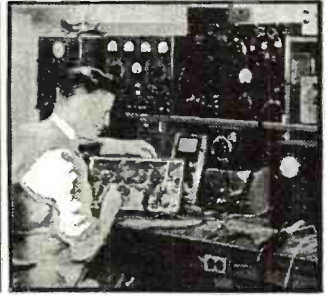

RADIO-ELECTRONIC SERVICE ENGINEER

# BE A RADIO ELECTRONICIAN

NOW YOU CAN PREPARE AT HOME IN SPARE TIME FOR AMAZING OPPORTUNITIES AHEAD IN RADIO — ELECTRONICS — TELEVISION



I SUPPLY A FULL RADIO SET for practical easy LEARNING

SPRAYBERRY TRAINING GIVES YOU BOTH TECHNICAL KNOWLEDGE—SKILLED HANDS

There's only one right way to learn Radio Electronics. You must get it through simplified lesson study combined with actual "shop" practice under the personal guidance of a qualified Radio Teacher. It's exactly this way that Sprayberry trains you. Supplying real Radio parts for learn-by-doing experience right at home. Thus, you learn faster, your understanding is clear-cut, you acquire the practical "know how" essential to a good-paying Radio job or a Radio business of your own.

I'll Show You a New, Fast Way to Test Radio Sets Without Mfg. Equipment

The very same Radio Parts I supply with your Course for gaining pre-experience in Radio Repair work may be adapted through an exclusive Sprayberry wiring procedure to serve for complete, fast, accurate Radio Receiver trouble-shooting. Thus, under Sprayberry methods, you do not have one cent of outlay for manufactured Test Equipment which is not only expensive but scarce.

### DON'T PUT IT OFF!

Get the facts about my training—now! Take the first important step toward the money-making future of your dreams. All features are fully explained in my big, Illustrated FREE Catalog which comes to you along with another valuable FREE book you'll be glad to own. Mail Coupon AT ONCE!

### ATTENTION VETERANS!

The Sprayberry Radio-Electronics Home Study Course has been fully approved for Veterans Training under the G.I. Bill of Rights. This is important to you! It's your opportunity to get our complete Radio Training through Government grant. Find out about your eligibility AT ONCE!

### Prepares You for a Business of Your Own Or Good Radio Job

My training will give you the broad, fundamental principles so necessary as a background, no matter which branch of Radio you wish to specialize in. I make it easy for you to learn Radio Set Repair and Installation Work. I teach you how to install and repair Electronic Equipment. In fact, you'll be a fully qualified RADIO-ELECTRONICIAN, equipped with the skill and knowledge to perform efficiently and to make a wonderful success of yourself.

### JUST OUT! FREE!

"How to Read Radio Diagrams and Symbols" is a valuable new book which explains in simple English how to read and understand any Radio Set Diagram. Provides the quick key to analyzing any Radio circuit. Includes translations of all Radio symbols. Send for this FREE book now, and along with it I will send you another big FREE book describing my Radio-Electronic training.

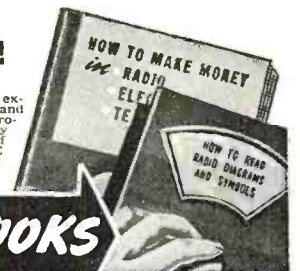

### GET FREE BOOKS

SPRAYBERRY ACADEMY OF RADIO  
F. L. Sprayberry, Pres.  
Room 2516  
Pueblo, Colorado

Please rush my FREE copies of "HOW TO MAKE MONEY IN RADIO, ELECTRONICS and TELEVISION," and "HOW TO READ RADIO DIAGRAMS and SYMBOLS."

Name ..... Age.....

Address .....

City ..... State.....

Tear off this coupon, mail in envelope or paste on penny postcard.



**AUDAX**  
 RELAYED-FLUX  
*Microdyne*

## The Importance of SPECIALIZATION

Aside from outstanding and long-acknowledged technical skill—our “Specialization Formula” is probably as fully responsible for the world-renowned AUDAX quality as any other single factor.

We proudly concentrate all our energies and resources upon producing the BEST pick-ups and cutters. Because we are specialists in this field, much more is expected of us. Because the production of fine instruments like MICRODYNE is a full time job, it stands to reason that we could not afford to jeopardize our reputation—EVER—by making pick-ups a side-line.

Now that Victory is ours, you may expect AUDAX improvements, refinements . . . master-touches to heighten the marvelous facsimile realism of AUDAX reproduction.

**AUDAX COMPANY**  
 500-N Fifth Ave., New York 18, N.Y.

*Creators of Fine Electronic-Acoustical Apparatus Since 1915*

Send for complimentary copy of our informative

**“PICK-UP FACTS”**

★ **BUY WAR BONDS**

*“The Standard by Which Others Are Judged and Valued”*



**W**E HAVE been conducting a survey on the needs of the postwar radio serviceman and amateur. Purpose of the survey was to find out what type of information would be of greatest help to our readers and which would be practical, workable, and informative. As a result we have started the wheels in motion on a special Radio Call Book Edition which will include complete and accurate information on the call letters, location, owner, frequency, etc., of practically every licensed transmitter throughout the world. All services will be included except those which cannot be heard in this country, or a few specialized services that would not be of general interest. So complete will be this call book that no matter what your interest in radio it will serve as valuable reference material either for yourself or as a source of information for your customers.

A complete worldwide listing of all amateur stations will be included and will be kept up to date (as will all other calls) every month in RADIO NEWS. With thousands of new Ham licenses soon to be issued and with many revisions we believe that this service will give the radio amateur the only up-to-the-minute accurate listing possible. In order that your Ham call letters, names, street addresses, etc., be included, we request all amateur readers send their correct listing as soon as possible so that they may be included in the initial issue. Those arriving too late will appear in the supplementary columns to follow. We realize that there has been considerable mortality within the ranks of the amateurs due to the hazards of war. This alone calls for continuous revisions. Maps, charts and other pertinent information will be included in the amateur section and these have been chosen from the best possible sources.

Radio servicemen have for many months past been faced with a continuous barrage of questions from their customers for information on short wave stations throughout the world. Such information has not been readily available. There have been many changes, as you know, as various armies moved in to take over existing enemy short wave transmitters. Many new ones have cropped up and

others have been obliterated. By giving the radio serviceman complete, worldwide listings of short wave stations and information on when to tune for them, he will be able to intelligently answer those questions and to stimulate interest with new customers for all wave receivers. These listings too will be kept up to date monthly. Other services also are of vital interest to the radio serviceman and all of them will be included in our Call Book Edition. Radio servicemen have also been burdened for information on how to tune for short wave programs. This has taken up a great deal of the radio-man's time. Times of broadcast in English for various short wave stations will be listed. With the large number of new services that will use radio there will be greatly stimulated interest in this type of listing. At this writing there is no published list of these new services. A large number of trucks, buses, railroads, etc., will use radio and all of these will be identified.

Marine listings will be very complete and accurate. Many of our readers are owners of small boats and others manufacture various types of marine radio equipment. Ship-to-shore radiophone is becoming commonplace and there has always been a lack of information about their location and frequency.

Complete up-to-the-minute listings of all broadcast transmitters will be included and will include short wave, long wave, FM, AM, relay, facsimile, etc.

The FCC is now receiving many applications for television transmitters. As fast as they are constructed and put on the air, they will be listed immediately in the Call Book or in the supplement.

Fixed services will include police, fire, municipal, geological, and sundry services will all be properly classified and listed.

As mentioned previously, it is our intention to include every licensed transmitter in any service which could be of possible interest to our readers.

We are planning to publish the Call Book yearly and to list supplementary information every month in RADIO NEWS. It's coming soon—watch for it. . . . .O.R.

**RADIO NEWS**



# ORDER YOUR NEW COMMUNICATIONS RECEIVER

NOW from ALLIED... For Earliest Delivery

**Available on Time-Payments  
Trade-ins Accepted**

BE ONE OF THE FIRST to own and enjoy one of these celebrated receivers. All models cover amateur, short-wave, and broadcast bands. War-proved features... plus latest bands. War-developments. Allied is a leader in the distribution of communications receivers. Place your order now for earliest delivery.

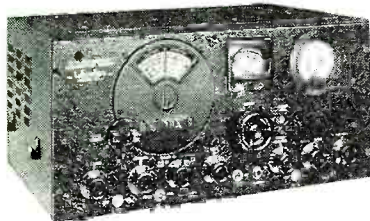

### HALLICRAFTERS S-36A

Hallicrafters' most advanced development in very-high-frequency, high-fidelity receivers. Combines AM, FM, and CW reception. Frequency range 27.8 Mc. to 143 Mc. continuous in 3 bands. Covers old and new FM bands. RF stage with acorn tube. Push-pull high fidelity output

stage. Four position tone control with bass boost. Sharp-broad selectivity switch. Dual purpose "S" and tuning meter. Oscillator compensated for frequency drift. Hermetically sealed transformers and reactors. Beat frequency oscillator, pitch variable from panel. Designed for service in any climate. Net..... **\$415**

PM23 Speaker, Net..... \$15.00

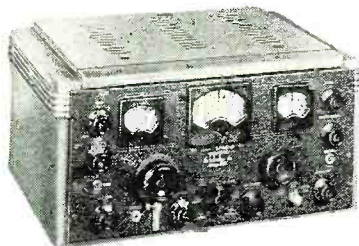

### HALLICRAFTERS SX-28A

Famous Super Sky-Rider. Frequency range 550 kc. to 42 Mc. continuous in 6 bands. Main tuning dial accurately calibrated in megacycles. Separate calibrated bandspread dial. Two r.f. stages. Lamb type 3 stage adjustable noise limiter.

Six position i.f. and crystal filter selectivity switch. Oscillator temperature compensated for frequency drift. Inertia flywheel tuning and pre-loaded gear drive on main and bandspread dials. Push-pull 8 watt output stage. Net..... **\$223**

PM23 Speaker, net..... \$15.00

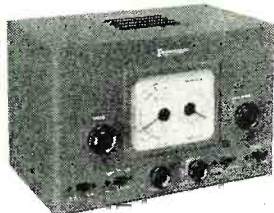

### ECHOPHONE EC-1A

Popular low-cost communications-type short-wave and broadcast receiver, with many new features. Covers entire tuning range from 550 kc. to 30 Mc. in 3 bands. For 115-125 volts AC-DC. Electrical bandspread on all bands with separate tuning control and dial. Dial calibrated in megacycles. Beat frequency oscillator

for CW reception. Automatic noise limiter. Built-in PM dynamic speaker. Headphones or speaker selected by panel switch. Housed in metal cabinet with gray wrinkle baked-on finish. Net..... **\$29.50**

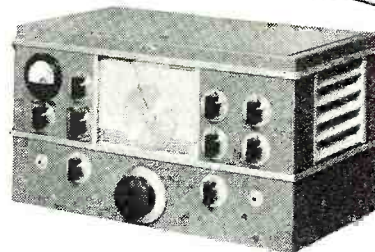

### NATIONAL NC-2-40C

One of National's top receivers. 490 kc. to 30 Mc. range in 6 tuning bands. Definite, accurate calibration for all bands. Actual single dial control.

Stable high frequency circuits. Frequency drift reduction to a negligible value by temperature compensation. Automatic voltage stabilization. Wide range adjustable series-valve-noise limiter. Flexible crystal filter. Phonograph or high level microphone pick-up jack. Special r.f. coupling circuits maintain full sensitivity. Net..... **\$225**

Speaker in matching cabinet, net..... \$15.00

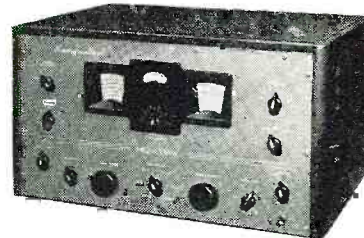

### HAMMARLUND HQ-129X

Designed to meet the most critical demands of professional operators. Full range .54 to 31 Mc., accurately calibrated. 4 calibrated Ham bands and one arbitrary scale. Variable selectivity crystal filter. Low drift beat oscillator for code and

locating stations. Antenna compensator. Voltage regulation. Compensated oscillator to reduce drift during warm-up. Automatic noise limiter. Earphone jack. 3 i.f. amplifier stages. 2 audio stages. For phone or CW. Net..... **\$129**

Speaker, net..... \$10.50

#### Other well-known receivers such as:

Hallicrafters SX-25 .....	\$ 94.50
Hallicrafters S-20R .....	60.00
Hallicrafters S-22R .....	74.50
Hallicrafters S-39 .....	110.00
National HRO .....	197.70
PM23 Speaker .....	15.00

Net, F.O.B. Chicago  
(All prices subject to possible change)

SEND YOUR ORDER TODAY FOR EARLIEST DELIVERY

ALLIED RADIO CORP., L. M. Dezettel W9SFW

833 West Jackson Blvd., Dept. 1-AA-6  
Chicago 7, Illinois

Please enter order for

Date.....

Model.....

Enclosed \$.....

Full Payment

Part Payment (Balance C.O.D.)

Please send full information on Communications Receivers and Time Payment Plan, without obligation.

Name.....

Address.....

City..... Zone..... State.....

# ALLIED RADIO

Everything in Radio and Electronics

833 W. Jackson Blvd. • Chicago 7, Illinois





Now YOU

THIS IS TO CERTIFY THAT  
**Frank's Radio Service**  
 has met the requirements to qualify as  
**RAYTHEON BONDED ELECTRONIC TECHNICIANS**  
*A Surety Bond Has Been Issued by the*  
**WESTERN NATIONAL INDEMNITY COMPANY,**  
 Beginning the \_\_\_\_\_ day of \_\_\_\_\_ 19\_\_\_\_, Bonding This Firm to:

1. GUARANTEE ITS RADIO REPAIR WORK FOR 90 DAYS FROM DATE PERFORMED and REPLACEMENT PARTS FOR 90 DAYS FROM DATE INSTALLED.
2. Use only parts of recognized quality in its repair work.
3. Not charge more than list price for parts installed.
4. Test customers' tubes as accurately and reliably as possible.
5. Keep charges for labor at a fair and reasonable level.
6. Perform only such work as is authorized.
7. Maintain the high quality service indicated by the experience required of all Bonded Electronic Technicians.
8. Maintain and use test equipment essential to good repair work and reliable tube checking.

*Signed and Sealed*

By A. E. [Signature]  
 RAYTHEON MANUFACTURING COMPANY  
A. E. [Signature], District Sales Manager

By [Signature]  
 WESTERN NATIONAL INDEMNITY COMPANY  
A. L. [Signature], Secretary-Treasurer  
 Dist. Offices and Telephone 175 West Jackson National, Chicago 4, Illinois





*can become a*

# BONDED ELECTRONIC TECHNICIAN

If you can qualify for this new, revolutionary Raytheon merchandising program, you can be sure of greater sales and profits than ever before . . . and you can forget your worries about "security" in the peacetime years ahead.

This program is the perfect answer to those who have been suggesting licensing, government regulation and other impractical "remedies" to protect the public from unethical radio service dealers.

The bond certificate illustrated, showing the code of ethics and 90 day guarantee, and backed by one of the nation's largest surety firms, will be issued to *each* service dealer who can meet the necessary qualifications.

It is only one unit in a *complete* plan which includes the largest, most effective selection of displays and helps ever offered to the radio tube industry.

As a Bonded Electronic Technician, you will **STAND OUT** in your community as the **TOP** radio service dealer . . . the one to be trusted with all kinds of radio service, the one in whom the public can have complete confidence.

So for more service business, increased sales of tubes and other parts, apply to your Raytheon distributor to become a Bonded Electronic Technician. Remember, for your protection Raytheon tubes are distributed only by leading parts wholesalers.

*Raytheon*  
*Manufacturing Company*

RADIO RECEIVING TUBE DIVISION

NEWTON, MASS. • LOS ANGELES • NEW YORK • CHICAGO • ATLANTA

**RAYTHEON**  
*Radio Tubes*



DEVOTED TO RESEARCH AND THE MANUFACTURE OF TUBES FOR THE NEW ERA OF ELECTRONICS

January, 1946

11



Designed for



Application

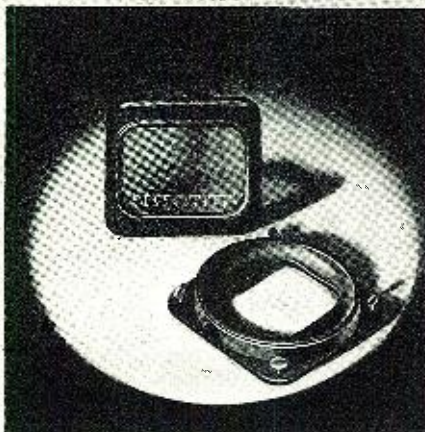

**THE NO. 80075 BEZEL  
FOR  
5" CATHODE RAY TUBE**

Another item in the Millen line of "Designed for Application" components. Bezel of cast aluminum with black wrinkle finish. Complete with neoprene cushion, green lucite filter scale and four "behind the panel" thumb screws for quick detachment from panel when inserting tube. Mounts in 5" diameter panel hole.

**JAMES MILLEN  
MFG. CO., INC.**

MAIN OFFICE AND FACTORY  
**MALDEN  
MASSACHUSETTS**



# Spot Radio News

★ Presenting latest information on the Radio Industry.

**By F. D. WALKER**

Washington Reporter

**A NEW SYSTEM** of assigning call letters to identify amateur radio stations has been issued by the Federal Communications Commission to permit assignment of thousands of additional calls without exceeding a limit of five symbols for any station.

Station calls will continue to be made up of numerals signifying call areas, preceded by letters completing a call for each station distinctive from all others. The number of call areas has been increased from nine to ten. Reassignment of some areas within states will be necessary so that no division of call area will exist and in order to make the various call areas more nearly equal in amateur numbers. FCC intends to make full use of the prefix K in the continental United States rather than in outlying areas only, reserving only distinctive two-letter prefixes for outlying areas, such as KG6AA to KG6ZZ for Guam and KV4AA to KV4ZZ for the Virgin Islands.

Most of the amateurs will prefer to be assigned their former call letters and, although calls are to be assigned systematically rather than on a request basis under the new system, FCC will whenever possible attempt to satisfy that desire. This principle of co-operation has applied not only to renewed and modified licenses, but also to new ones following a period of inactivity, and it will be continued so that if an amateur obtains a new license for his former location it will ordinarily include assignment of the old call without change. It is expected that in the great majority of instances, more than 75 per cent, a former call can be assigned.

The old system of assigning amateur call letters was based on nine call areas, identical with the inspection districts long since abandoned. The call-area boundaries cut through a number of states, tending to cause confusion and delay in processing applications. The areas differed greatly in numbers of amateur stations, with the result that a letter series was exhausted in one area long before half of it was used in another. Particularly unequal was the use of W and K as the initial letters in amateur station calls—the W for all stations in continental U.S. and the K only for the relatively small number in outlying sections.

The new call areas are: (1) New England (six states); (2) New York and New Jersey; (3) Pennsylvania,

Delaware, Maryland, and District of Columbia; (4) Virginia, North and South Carolina, Georgia, Florida, Alabama, Tennessee, Kentucky, Puerto Rico, and Virgin Islands; (5) Mississippi, Louisiana, Arkansas, Oklahoma, Texas, and New Mexico; (6) California, Hawaii, and Pacific possessions other than those included in Area 7; (7) Oregon, Washington, Idaho, Montana, Wyoming, Arizona, Nevada, Utah, Alaska and adjacent islands; (8) Michigan, Ohio, and West Virginia; (9) Wisconsin, Illinois, and Indiana; (0 or zero) Colorado, Nebraska, North and South Dakota, Kansas, Minnesota, Iowa, and Missouri.

## SOON AFTER ANNOUNCEMENT

of the new system of issuing call letters, the FCC sent out an order permitting approximately 60,000 radio amateur operators still in good standing to return to the air on and after 3 a.m., November 15, 1945. Except for a provisional period of operation in the 112 to 115.5 megacycle band from August 21 to November 15, 1945, the amateurs had been off the air since Pearl Harbor. The order provided that all amateur station licenses valid between December 7, 1941, and September 15, 1942, would be validated for a period of six months—to May 15, 1946. The six-month period was designated to permit orderly processing of new as well as renewal and modification applications.

The order assigned the following frequency bands to amateur use, since authority to operate in the 112-115.5 megacycle band ended on the day amateur licenses were revalidated:

28.0 to 29.7 megacycles using type A1 emission.

28.1 to 29.5 megacycles using type A3 emission.

28.95 to 29.7 megacycles using special emission for radiotelephony (FM).

56.0 to 60.0 megacycles using types A1, A2, A3, and A4 emission and, on frequencies 58.5 to 60.0 megacycles, special emission for radiotelephony (FM). This band is available to amateur operation until March 1, 1946, at which time television broadcast stations now assigned to frequencies within the 50 to 54 megacycle band will vacate this band. Then it will be assigned to amateur radio service in lieu of the 56-to-60 megacycle band.

144 to 148 megacycles, using A1, A2, A3, and A4 emissions and special emissions for radiotelephony and radiote-

**RADIO NEWS**



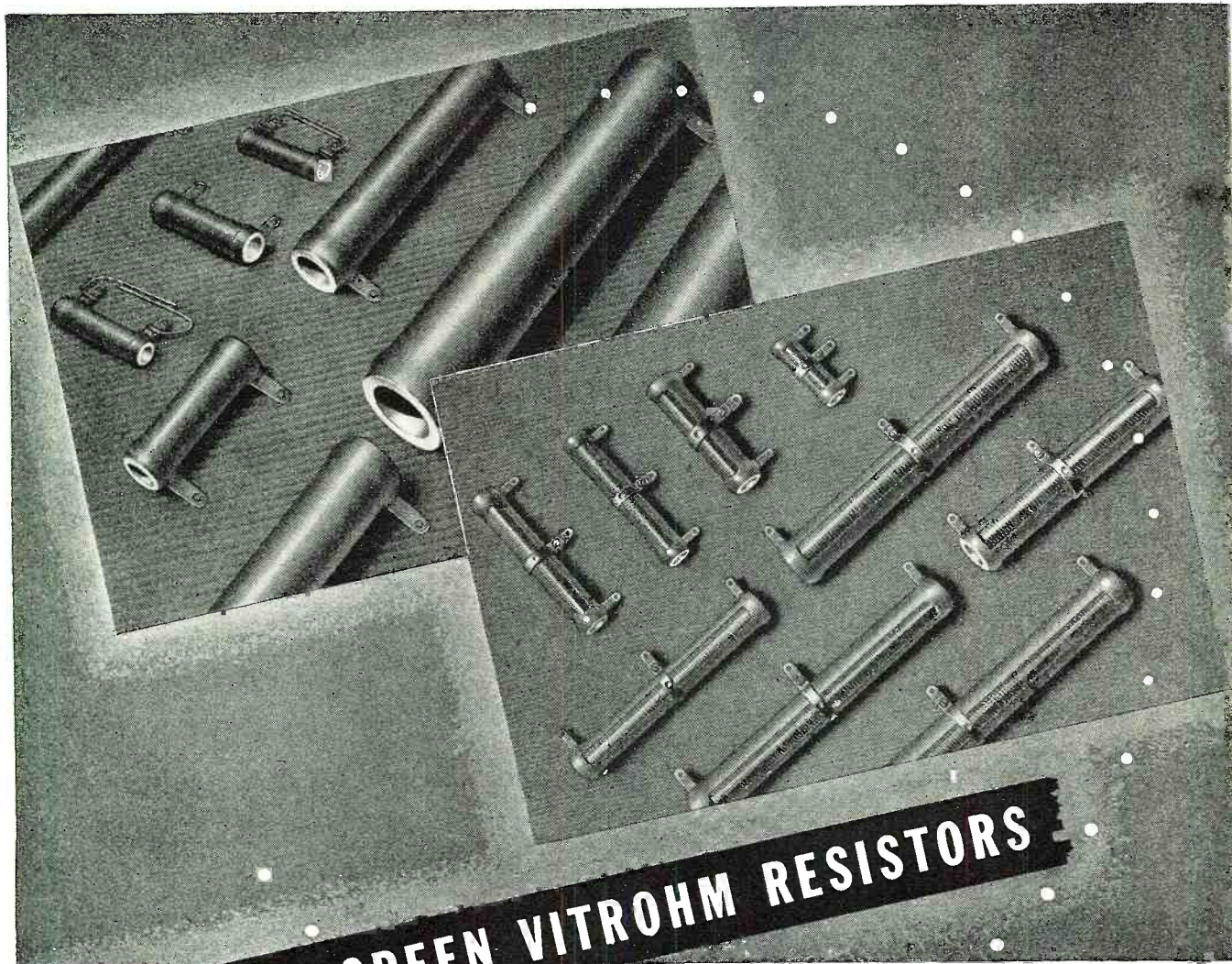

**LOOK FOR GREEN VITROHM RESISTORS**

The Green Vitrohm Enamel used in the manufacture of all Ward Leonard Vitrohm Resistors and Rheostats is an exclusive development of Ward Leonard Laboratories — the result of more than 50 years of intensive research in resistor enamels.

Pick the Resistor with the Green Vitrohm Enamel and you pick the best. Now available at your Radio and Electronic parts distributor.

Write for your free copy of our Radio and Electronic Resistor Catalog.

**WARD LEONARD ELECTRIC CO.**

*Radio and Electronic Distributor Division*

53 WEST JACKSON BLVD., CHICAGO, ILL.



**WARD LEONARD**  
ACCEPTED MEASURE OF QUALITY

**RESISTORS  
RHEOSTATS  
RELAYS**





The  
**SPINTITE  
WRENCH**  
Works Like a  
Screw Driver

Speeds Production on  
the assembly line.

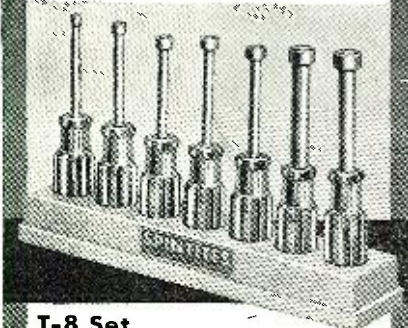

T-8 Set

Seven Standard Hex  
sizes in a Convenient  
Holder.



No. T-51

**CHUCK TYPE  
SPINTITE**

with Seven SPINTITES, three  
Screw Drivers and Ream-  
awl in Leatherette Roll.

Send for Catalog No.  
141 picturing a full line  
of Automobile, Aircraft  
and Radio Tools.



**STEVENS WALDEN, INC.**  
468 SHREWSBURY STREET  
WORCESTER, MASSACHUSETTS

legraphy (FM). The portion of this band between 146.5 and 148 megacycles will not be used, however, by any amateur stations within fifty miles of Washington, D.C., or Seattle, Washington.

2300 to 2450 megacycles, 5250 to 5650 megacycles, 10,000 to 10,500 megacycles, and 21,000 to 22,000 megacycles, using on these four bands A1, A2, A3, A4, and A5 emissions and special emissions for FM.

The new order canceled the following orders: No. 72 and amendments, prohibiting amateur radio operators and amateur radio stations licensed by FCC from exchanging communications with operators or radio stations of any foreign government or located in any foreign country; No. 73, prohibiting portable and portable-mobile radio station operation by licensed amateur operators and stations on frequencies below 56,000 kilocycles; No. 87 and No. 87A, prohibiting all amateur radio operation; No. 87B, suspending the issuance of renewed or modified amateur station licenses.

The new order (No. 130) does not affect amateur operator licenses. Unlike amateur station licenses, operator licenses were issued generally throughout the emergency period. Those operators whose licenses were suspended or whose station licenses were revoked are not covered by the blanket revalidation order.

**LONG-DISTANCE RADIO COMMUNICATION** soon will benefit from war-developed information concerning the ionosphere, according to Signal Corps scientists. Experience obtained during the stress of military urgency and new discoveries concerning the characteristics of the higher atmosphere have reduced the uncertainties of long-range reception.

The ionosphere is the electrically charged atmosphere that encircles the earth many miles above its surface. Because it has the property of reflecting short-wave radio signals, it is the medium that makes it possible to send messages over long distances. Low-frequency or long waves are transmitted mostly along the earth's surface, but high-frequency or short waves are transmitted over much greater distances because they travel into the ionosphere, where they are refracted back to earth and thus overcome the earth's curvature.

The ionosphere is a complicated region composed of several layers, each with different ionic characteristics. The layers change in their height above the earth and also in ionic density from day to night, from winter to summer, and during the progress of the sunspot cycle.

Four different layers of the ionosphere have been identified. The lowest, known as the *D* layer, is about 38 miles above the earth. The *E* layer is about 75 miles, the *F1* layer 110, and the *F2* layer about 250 miles above the earth. These distances are approxi-

mate and are for a summer day. At night, because of the changing solar energy, the *D* layer disappears, the *E* layer retains its relative position, and the *F1* and *F2* layers combine about halfway between their daytime locations to form the *F* layer.

Since it was believed that the sun's energy is the only factor affecting the ionosphere, it was assumed that the ionosphere characteristics would be the same for all points in a given latitude at the same local time. Pursuing that theory, scientists established at different latitudinal locations stations to record ionospheric data. A modified version of radar was employed. A radio pulse was projected vertically, and the time required for it to travel to the ionosphere and back to earth was measured with an oscillograph. By using different frequencies and computing the time for each, the distances and densities of the several ionospheric layers could be ascertained. Notes were taken continuously so that forecasts could be made covering extensive periods.

Considerable success was attained by the application of this latitudinal theory, but the data was not always accurate, particularly with reference to points in Asia. A further study of the disparities led to the discovery that the geomagnetic poles and geomagnetic latitudes have a definite influence on the ionosphere. This involved a revision of the location of stations, since not only geographic latitudes but geomagnetic latitudes as well had to be considered. This discovery and the resultant theory of longitudinal equivalence greatly improved the accuracy of radio propagation forecasts and is an important contribution to long-range communication.

**RECONVERSION PRICING METHODS** for consumer-type radios and phonographs have been listed in detail by OPA. Consumer prices will be about what they were in March 1942. Two kinds of adjustments have been made, however, to iron out inequities that had crept into the retail price picture. First, where retail prices in March 1942 included excise taxes newly imposed in October 1941 at the manufacturing level and pyramided through to the consumer by means of percentage mark-ups at successive levels of distribution, OPA has reduced those retail prices to the point where they include only the original dollar amount of the manufacturer's 1941 excise tax. This policy has been consistently followed, OPA said, on all consumer items on which new wartime taxes were imposed.

Second, in cases where retailers by March 1942 had established individual ceilings higher than those in the manufacturer's October 1941 suggested list of retail prices, OPA has reduced these prices by the amount of the increase over list. Such price increases did not represent any actual increase

(Continued on page 147)



**FOR REAL JOB SECURITY  
NOW AND IN THE FUTURE...**

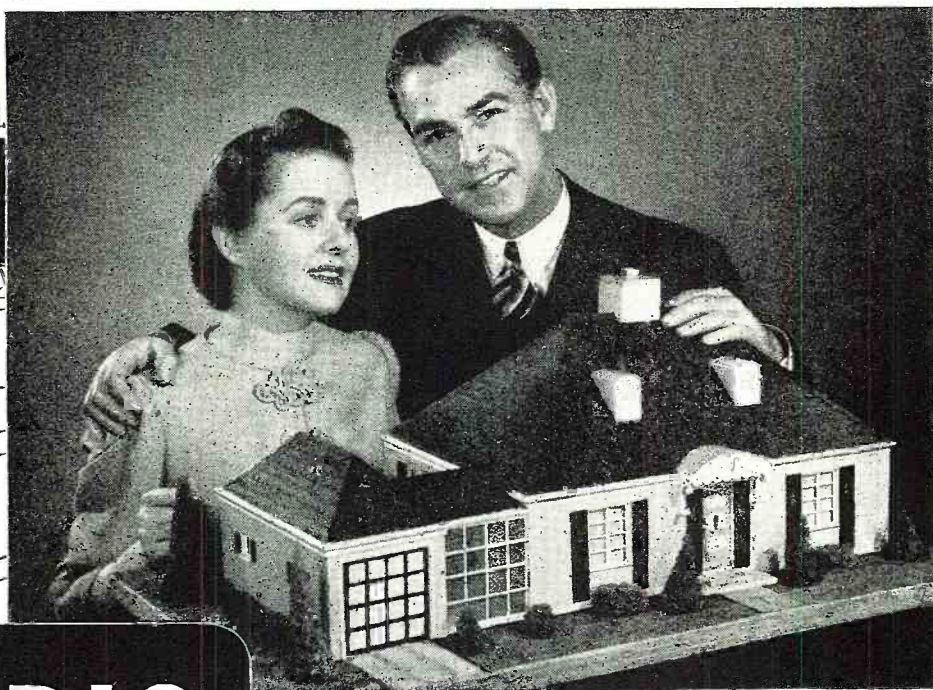
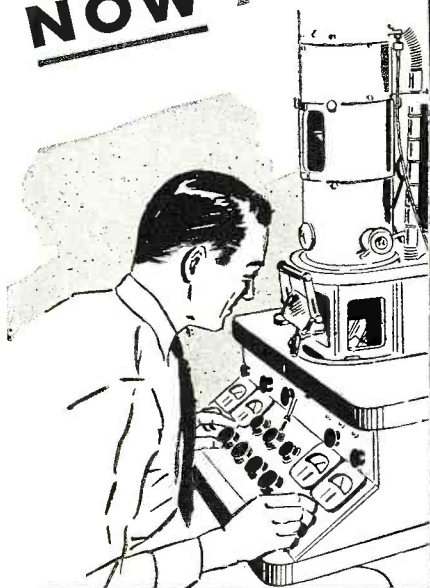

*Learn* **RADIO  
ELECTRONICS**  
AT HOME OR IN  
OUR CHICAGO LABORATORIES

Now that the war is over and civilian production is getting under way . . . choose a field that promises *real job security*. Radio, Electronics—and all the many applications and opportunities of each, are wide open to *trained men!* . . . in broadcasting, manufacturing, merchandising, installing and servicing Communications, Sound Pictures, Transportation, Aviation Radio, etc.

If you are even slightly mechanically minded . . . if you can follow clear, easy-to-understand instructions—you can learn all about Radio-Electronics and its many applications in Television, Radar, etc. DeForest's modern A-B-C Method makes it seem simple. The exclusive home training advantages of actual MOVIES and "Synco-Graphic" Lesson

Texts, prepared under the personal supervision of Dr. Lee DeForest, the "Father of Radio," actually helps make learning *faster-easier* . . . and much more interesting than *ordinary* methods. You make 133 fascinating experiments with 8 Big Kits of Radio Parts and Assemblies, too—a practical "Shop Training" right in your own home. If you prefer, you can take the complete course in our modern Chicago Laboratories . . . in the heart of the Radio Industry.

**SEND FOR FREE BOOKS FOR FURTHER INFORMATION**

Use your *free time today* to store up *practical knowledge and experience for good pay and job security tomorrow!* Mail coupon *now* for complete information—get the big "Victory for You!" book and Equipment folder—see how easy it is for you to get started at once. No obligation.



E. B. DeVry, President  
DeFOREST'S TRAINING, INC.  
2535-41 North Ashland Avenue, Dept. RN-C1  
Chicago 14, Illinois, U.S.A.  
Please send me your "VICTORY FOR YOU!"  
BOOK and EQUIPMENT FOLDER

Name \_\_\_\_\_ Age \_\_\_\_\_

Address \_\_\_\_\_

City \_\_\_\_\_ Zone \_\_\_\_\_ State \_\_\_\_\_

If under 16, check here for special information.  If a veteran of World War II, check here.

**DeFOREST'S TRAINING, INC.**  
CHICAGO, ILL.

January, 1946



## COLLINS 32RA RADIO TRANSMITTER\*



## A deservedly popular 50 watter...

THE COLLINS 32RA\* was introduced in 1939 as a quality designed, quality built radio communication transmitter, broadly adapted to most applications within its power and frequency scope.

It, or its d-c version—the 32RB†—was immediately put into service by airlines for control towers, by oil pipelines for emergency systems, by fishing companies for fleet control, and by other widely different types of industrial users.

It was found to be rugged, simple to operate, easy to service, and so thoroughly and universally satisfactory that a rising commercial demand was halted only by the war. During the entire war the Armed Forces employed thousands of these transmitters. A typical use was

that of control towers on air training fields throughout the country.

\*COLLINS 32RA—Power source: 115 *volts alternating current*. Power output, 50 watts phone; 75 watts CW. Frequency range, 1.5 to 15mc. Four frequencies instantly selected by panel control.

†COLLINS 32RB—Power source: 12, 24, 32 or 110 volts *direct current*. Dynamotor, self-contained. Otherwise identical with 32RA.

If you would like specifications and design data, write us for new, illustrated bulletin. Collins Radio Company, Cedar Rapids, Iowa; 11 West 42nd Street, New York 18, N. Y.

..... IN RADIO COMMUNICATIONS, IT'S ...





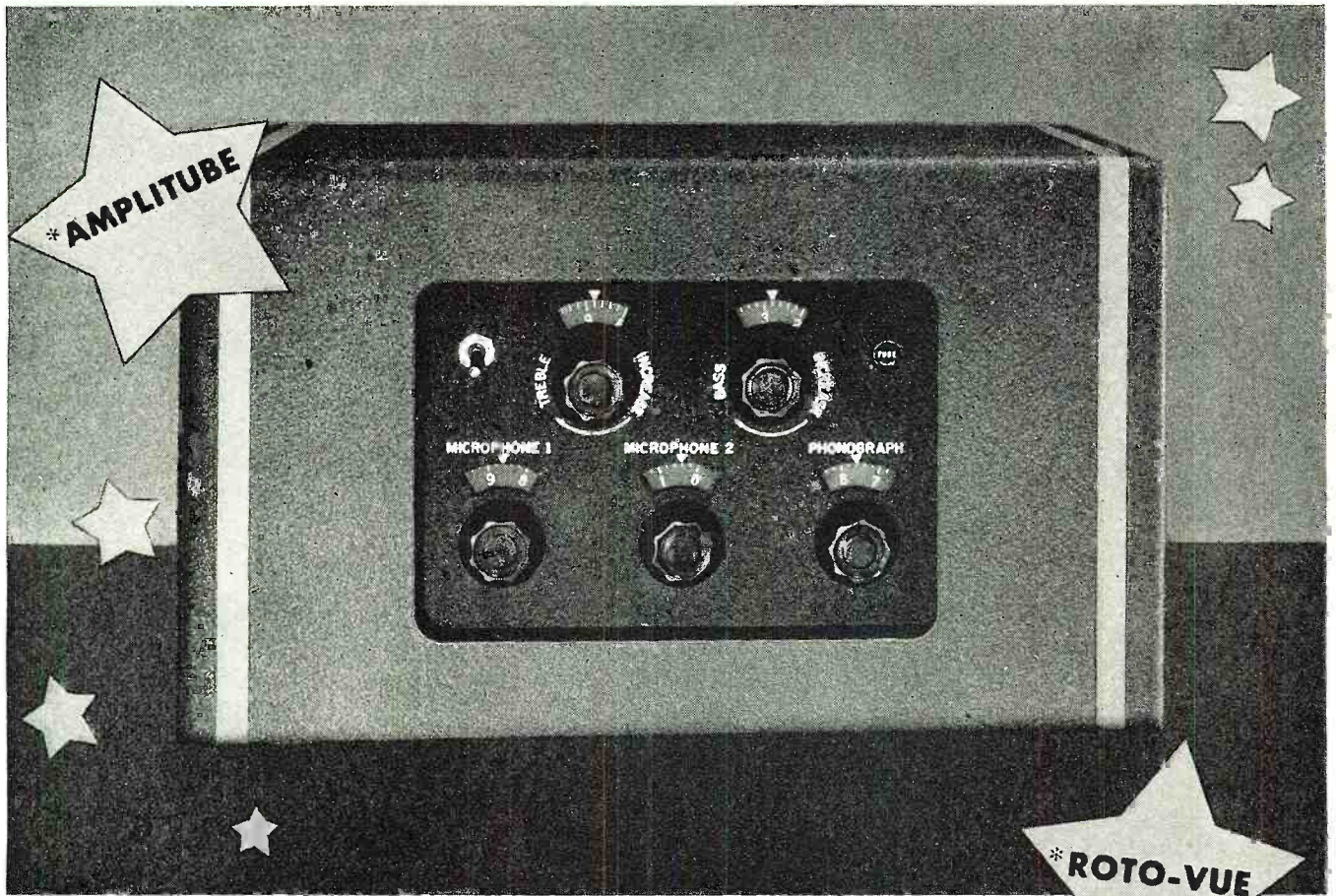

*Ethical Engineering* is the Basis of   
**Eastern's 21 STAR FEATURES**

  **\* UNICABLE**



Ethical engineering at Eastern is the history of many years in the service of sound amplification. The 21 Star Features are the result of intensive experience dating back to the early days of radio—the pioneer 20s! Today this engineering background accounts for the many innovations we have designed for the new 1946 Eastern Amplifiers—the 21 Star Features that produce Eastern's

famous *Quality Performance*. No other amplifiers, regardless of price, incorporate so many novel and useful features. . . . For complete information and price list—for the first edition of our 1946 Catalog—write today! . . . Eastern Amplifier Corporation, 794 East 140th Street, New York 54, N. Y. Dept. 1E.

  **RECESSED CONTROLS**

  **CODED CABLE**

**EASTERN**   **AMPLIFIERS**

\*U.S. Reg'n Applied For.



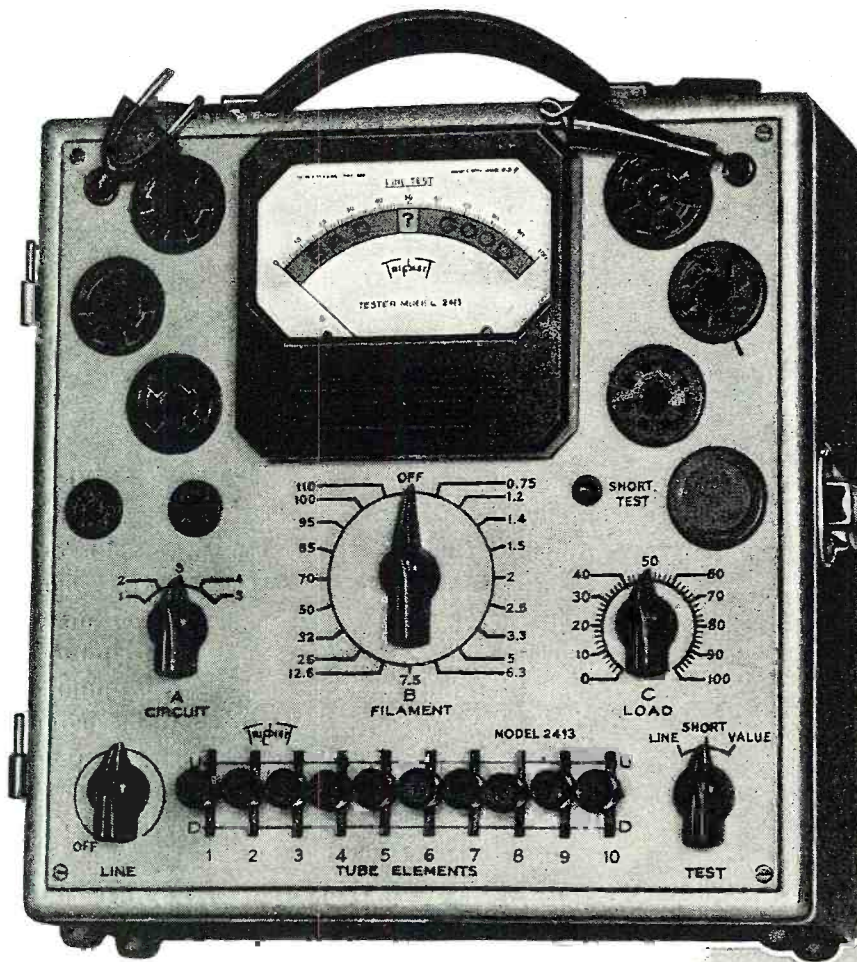

**MODEL  
2413**



is another  
member of the  
**NEW TRIPPLETT**  
Square Line



# The New Speed-Chek Tube Tester

**MORE FLEXIBLE • FAR FASTER • MORE ACCURATE**

Three-position lever switching makes this sensational new model one of the most flexible and speediest of all tube testers. Its multi-purpose test circuit provides for standardized VALUE test; SHORT AND OPEN element test and TRANSCONDUCTANCE comparison test. Large 4" square RED • DOT life-time guaranteed meter.

Simplicity of operation provides for the fastest settings ever developed for practical tube testing. Gives individual control of each tube element.

New SQUARE LINE series metal case 10" x 10" x 5½", striking two-tone hammered baked-on enamel finish. Detachable cover. Tube chart 8" x 9" with the simple settings marked in large easy to read type. Attractively priced. Write for details.

## *Additional Features*

- Authoritative tests for tube value; shorts, open elements, and transconductance (mutual conductance) comparison for matching tubes.
- Flexible lever-switching gives individual control for each tube element; provides for roaming elements, dual cathode structures, multi-purpose tubes, etc.
- Line voltage adjustment control.
- Filament Voltages, 0.75 to 110 volts, through 19 steps.
- Sockets: One only each kind required socket plus one spare.
- Distinctive appearance with 4" meter makes impressive counter tester — also suitable for portable use.



# Triplett



**ELECTRICAL INSTRUMENT CO. BLUFFTON, OHIO**  
**RADIO NEWS**



# Announcing

MODEL  
**A-12**

**GYROPILOT\***

THIS SIMPLE control unit gives the human pilot complete automatically stabilized control of his aircraft at all times.

## A-12 FOR . . .

- Automatic approach and automatic landing
- Perfectly banked turns at *any* air speed—automatically
- Gyrosyn Compass directional control—continuously slaved to the magnetic meridian
- Automatic holding of any selected altitude
- Automatic trim of elevator controls regardless of changing load conditions
- Utmost in passenger comfort—precise control and elimination of over-control, “hunting,” and “wallowing”
- Electrical and mechanical interlocks—automatically insuring proper manual operation
- Automatic and instantaneous synchronization—no matching of pointers or other indications
- Maximum ease of installation and simplified maintenance—any unit can be replaced in a matter of minutes



Our Aeronautical Department invites your inquiries on A-12 Gyropilot installations.

\*TRADE-MARK REG. U. S. PAT. OFF.

**SPERRY GYROSCOPE COMPANY, INC.** GREAT NECK, N. Y.



*Division of the Sperry Corporation*

★  
LOS ANGELES • SAN FRANCISCO • SEATTLE • NEW ORLEANS  
CLEVELAND • BROOKLYN • HONOLULU

**GYROSCOPICS • ELECTRONICS • RADAR • AUTOMATIC COMPUTATION • SERVO-MECHANISMS**



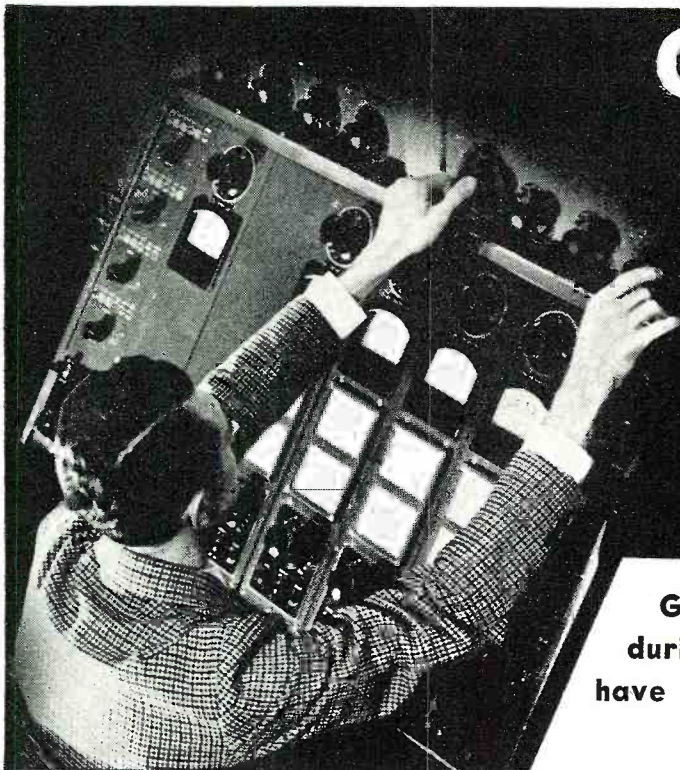

# Get Ready for POSTWAR RADIO ELECTRONICS AND TELEVISION NOW!

Great strides of progress have been made during the war. New equipment, methods, uses have been developed. Keep in the lead yourself with modern

## SHOP METHOD HOME TRAINING BY A GREAT ESTABLISHED RESIDENT SCHOOL



NATIONAL SCHOOLS HAS BEEN BRINGING OPPORTUNITY TO AMBITIOUS MEN FOR MORE THAN A THIRD OF A CENTURY. Above and to the right are two departments in this great school where modern developments are analyzed to provide National students with first-hand knowledge of short cuts and trade secrets. For full details fill out the coupon.

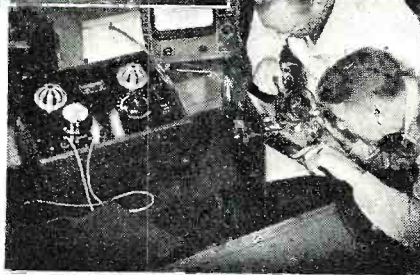

Take your place in the forefront of Radio, Television and Electronic progress. Get your share of the NEW business. War inventions and improvements—walkie-talkies, radar, aircraft control and communications—will quickly be adapted to civilian use. F.M. is winning almost universal acceptance and use.

Everywhere you turn new and important changes in the field of Radio are being put into operation every day. Television is rapidly being perfected. Electronics is being applied to industry and better living. The successful technician MUST KEEP UP WITH PROGRESS if he is going to be sure of his job—GET AHEAD IN BUSINESS.

National Schools presents a Radio and Electronic training system geared to the rapid advancement of the industry itself. Here is an exclusive home training system based on the shop methods as practiced in one of the World's foremost vocational education centers—the actual shops and experimental laboratories of this National institution. Send the coupon on the next page for complete details. Only National can bring you this type of training for only National has the shops, equipment and experimental laboratories for the development and extension of the system.

### Use This Modern Electronic Laboratory



The very essence of National Shop Method Home Training is EXPERIENCE. You get to know Radio and Television circuits by building them yourself. You get

first-hand knowledge of how instruments work by a sound analysis and construction system.

You build a beautifully toned, high fidelity, long distance modern superheterodyne re-

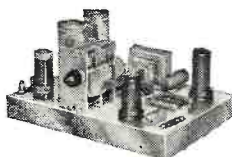

ceiver from the parts furnished with your course. In this way you have a thorough understanding of the superheterodyne principle.

You learn modulation, beat frequency and

signal generation by building yourself a small, operating radio transmitter with National parts. You get to know and understand the process of creating

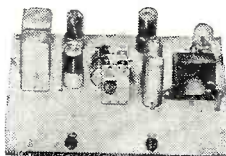

audible signals by electronic means by conducting experiments with a National Audio Oscillator.

You conduct cathode ray experiments to gain a first-hand knowledge of the operation, repair and maintenance of Television equipment. Hundreds of experiments may be performed to gain first-hand experience with your National laboratory equipment.



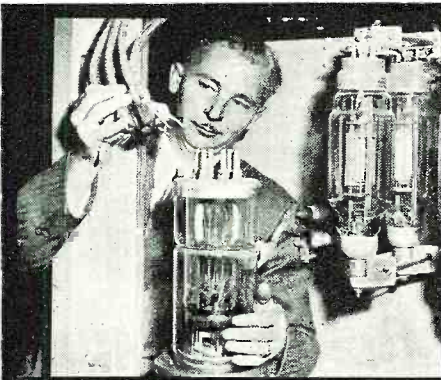

## New Fields

Electronics is already a most important factor in industry. Many manufacturing processes depend on electronic controls—employ electronic processes. In medicine and agriculture too, electronics is being used extensively. Are you ready to cash in on this development in a field that is so close to radio?

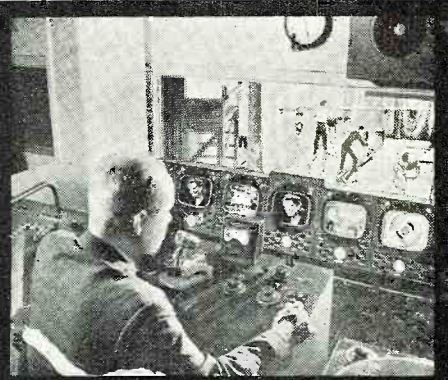

## New Equipment

Every day you learn of new types of radios and improved television—new electronic devices. Fac-simile, F.M., Radar, Sonar—all present new problems of manufacture, operation and maintenance that demand training and experience. Consider your advantages if you have the necessary preparation to tackle this work.

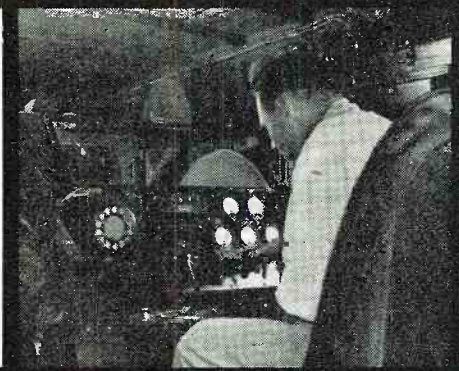

## New Hook-Ups

The relatively simple wiring of the radio receiver of a few years ago is as out-of-date today as one of the first automobiles. The new Radio and Television sets, and Electronic devices demand a thorough knowledge of new principles. National brings its students the results of continuous research and improved methods.

# NEW OPPORTUNITIES

Think what all this great progress in Radio, Electronic power and control and Television means to YOU PERSONALLY—you who are already in Radio or have a natural inclination toward it. The greatest opportunity of a lifetime is right within your grasp.

Compare the job you now have or expect to get when you are out of service or your present war job with the great future presented you by the broad field of Electronics.

Literally tens-of-thousands of technicians are needed in Radio and Television stations and communications companies all over the country—to operate, maintain and repair equipment. The man who **knows modern methods and equipment** is welcome almost at his own price.

Latest figures show that Radio represents a **5-billion dollar industry** and, in the opinion of experts, it is a **secure, well established, basic** type of business offering **steady employment**. Television, according to authorities, offers **half a million openings** right at the start. The man trained

in modern Electronics CAN CHOOSE THE KIND OF INDUSTRY HE WANTS—THE PART OF THE COUNTRY HE PREFERS AND THE KIND OF POSITION MOST SUITABLE.

### You Want Action

With this amazing speed-up training you can progress just as quickly as you wish—start taking advantage of your new found knowledge and experience in a very short time. Send the coupon below and learn the facts about this great educational development. Try out the **FREE SAMPLE LESSON** and see for yourself what you can accomplish so quickly and easily with the remarkable **SHOP METHOD HOME TRAINING**.

In a few months—perhaps only weeks—you may start making good money; maybe accept a **BIG PAY JOB** in industry—**GET INTO A PROFITABLE, LIFETIME BUSINESS OF YOUR OWN**, with little or no capital investment.

Take the first step now. Fill out and mail the coupon below.

# FREE LESSON

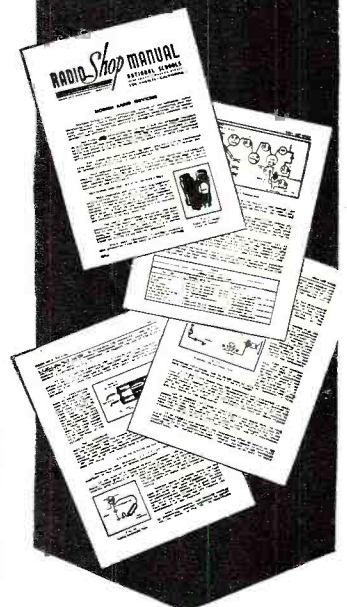

## Get this BOOK

Here is an interesting forecast of the future of Radio and the opportunities present for you in this, and allied fields right now. It is profusely illustrated and describes the jobs waiting for trained men everywhere. Send the coupon below for your copy.

## NATIONAL SCHOOLS

LOS ANGELES 37, CALIFORNIA EST. 1905

### MAIL OPPORTUNITY COUPON FOR QUICK ACTION

National Schools, Dept. RN-1  
4000 South Figueroa Street, Los Angeles 17, California

(Mail in envelope or paste on penny post card)

Mail me FREE the two books mentioned in your ad including a sample lesson of your course I understand no salesman will call on me.

NAME ..... AGE .....

ADDRESS .....

CITY ..... STATE .....

Include your zone number

## Here Are Some Samples of Success in Radio by National Graduates

National Shop Method Home Training wins good jobs, independence and security quickly. Take the word of National men who have established records in their favorite Radio, Television, or other branches of Electronics:



Joseph Grumien, Lake Hiawatha, New Jersey writes: "My latest offer was \$5,800.00 as Radio Photo Engineer but I'm doing well where I am now engaged. I am deeply indebted to National."



Robert Adamsen, Kearney, Nebraska, National graduate, has two radio jobs—makes double pay as a radio instructor and an engineer at Station KGFV. He writes: "I am proud of my National training and appreciate the cooperative spirit."



From O. K. Ivey, Washington, D. C., comes this endorsement: "I believe National offers the best course to be had... Keep up the good work."



Here's a statement from R. R. Wright, Blackfoot, Idaho: "Due to my training at National I was selected to instruct in the laboratory work of Navy and Marines."

Read what hundreds of other enthusiastic students have written about National Training. Send in your coupon today.





RCA's new television camera has a super-sensitive "eye" that sees even in the dimmest light—indoors or outdoors.

## ***A television camera "with the eyes of a cat"***

As a result of RCA research, television broadcasts will no longer be confined to brilliantly illuminated special studios—nor will outdoor events fade as the afternoon sun goes down.

For RCA Laboratories has perfected a new television camera tube, known as Image Orthicon. This tube, a hundred times more sensitive than other electronic "eyes," can pick up scenes lit by candlelight, or by the light of a single match!

This super-sensitive camera opens new fields for television. Operas, plays, ballets will be televised from their original performances in the darkened theater. Out-

door events will remain sharp and clear on your television set—until the very end! Television now can go places it could never go before.

From such research come the latest advances in radio, television, recording—all branches of electronics. RCA Laboratories is your assurance that when you buy any RCA product you become the owner of one of the finest instruments of its kind that science has achieved.

Radio Corporation of America, RCA Building, Radio City, New York 20. Listen to *The RCA Show*, Sundays, 4:30 P. M., Eastern Time, over NBC.

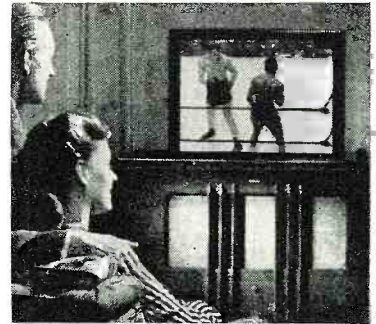

RCA Victor television receivers with clear, bright screens will reproduce every detail picked up by the RCA super-sensitive television camera. Lots of treats are in store for you. Even today, hundreds of people around New York enjoy regular weekly boxing bouts and other events over NBC's television station WNBC.



**RADIO CORPORATION of AMERICA**



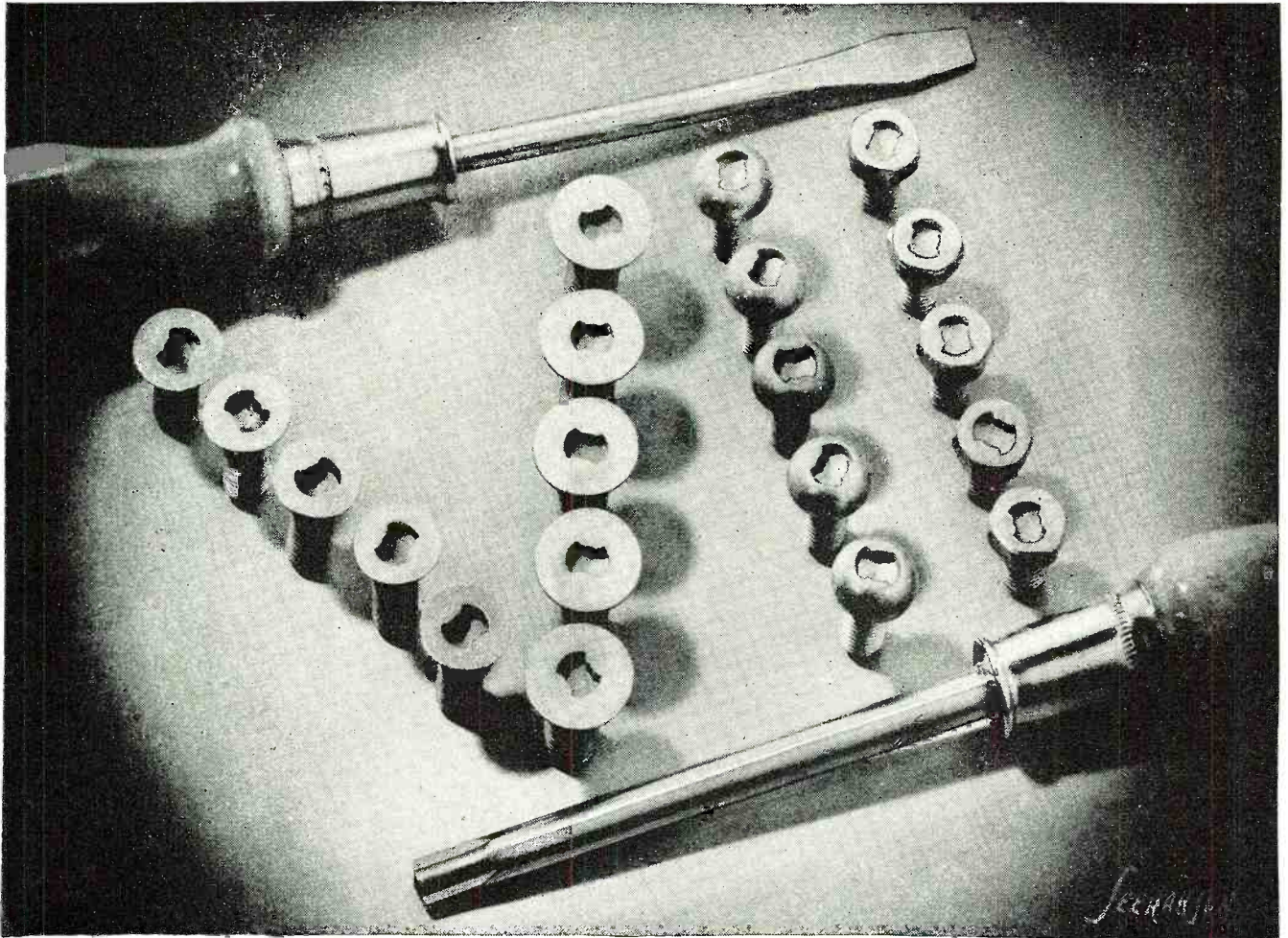

## Seven Major Features

have established  
CLUTCH HEAD as  
the most modern

screw on the market . . . for safer, speedier production and lower final cost.

- I** The wide roomy Clutch, an easy-to-hit target, inviting operator confidence and speed.
- II** Center Pivot entry to prevent canting; deep positive engagement for protection against slippage . . . safeguarding manpower and materials.
- III** No end pressure. The straight-walled Clutch matched by straight-sided driver disposes of "ride-out" tendency as set up by "tapered" drive home.
- IV** CLUTCH HEAD's exclusive Lock-On unites screw and bit as a unit . . . substituting easy one-handed reaching for fumbling with mechanical fingers.
- V** The rugged Type "A" Bit delivers a longer uninterrupted spell of service . . . and may be repeatedly reconditioned to original efficiency by a 60-second application of the end surface to a grinding wheel.
- VI** Simplified field service . . . because CLUTCH HEAD is the only modern screw operative with the ordinary type screwdriver, or any flat blade, of proper width.
- VII** Here again the CLUTCH HEAD Lock-On saves the day. With the Type "A" Bit, rusted-in and frozen-in screws may be withdrawn undamaged and held secure against dropping for re-use.

Because CLUTCH HEAD is "The Screw That Sells Itself," we invite you to personally examine and test these features. Your re-



quest will bring you, BY MAIL, a package assortment of CLUTCH HEAD Screws and sample Type "A" Bit; also fully illustrated Brochure.

**UNITED SCREW AND BOLT CORPORATION**

CLEVELAND 2

CHICAGO 8

NEW YORK 7



# The PROFESSIONAL Receiver



*New* **HQ-129-X** \$129 AMATEUR NET  
LESS SPEAKER

Price subject  
to change  
without notice.

WRITE TODAY FOR  
TECHNICAL BOOKLET

*There is a difference.* The HQ-129-X receiver is designed purely from a professional point of view. The treatment of every detail is based on professional requirements. As soon as your dealer has the HQ-129-X in stock, go in and look it over and try it—you will see, hear and feel the difference.



## HAMMARLUND

THE HAMMARLUND MFG. CO., INC., 460 W. 34TH ST., NEW YORK 1, N. Y.  
MANUFACTURERS OF PRECISION COMMUNICATIONS EQUIPMENT





# The Army's RADIO RELAY Equipment

By **ANDREW R. BOONE**

*Although military in design, the technical knowledge obtained in the operation of this equipment applies equally as well to commercial relay stations, now under construction.*

**T**ELEPHONE and teletype communications cannot easily be installed and maintained over long distances where streams, the sea, mountains, valleys, and other obstacles interfere. Destruction of wires by either enemy or friendly action, or by the ravages of nature, imposes added difficulties in maintaining communications by wire. Too, in warfare of movement, the wires simply cannot be moved forward as rapidly as needed.

The solution, as developed by the U. S. Signal Corps Laboratories in con-

junction with leading American equipment manufacturers, is radio relay. First tactical use of radio relay equipment took place during the Tunisian campaign, when 250-watt FM radio sets were installed between Tunis and Algiers, a distance of 418 miles. Three relay stations, or four *jumps*, were employed, since the high frequency used, while providing good quality, limited the range between a transmitter and its receiver. This circuit carried one channel teletype and no voice. The same equipment was used later

Radio relay installation on Mt. Frazier, elevation 8026 feet, near Lebec, Calif., and the Tejon Pass. This station relays twenty-four two-way conversations. Teletypewriter or facsimile picture transmission may be substituted in place of any of the voice channels.

during the Sicilian and Italian campaigns. During the Anzio beachhead operation this equipment provided practically the only means of communication between the beachhead and the bulk of army forces below the beachhead.

The equipment was regular radio equipment modified to operate in radio relay systems. Its success prompted the rapid and extensive development by Signal Corps Engineering Laboratories, Bradley Beach, N. J., of four different sets, three of which saw combat service before the war ended. These are known as radio sets AN/TRC-1, AN/TRC-5, AN/TRC-6, and AN/TRC-8. AN designates the equipment as both army and navy; T means transportable; R means radio receiving and transmitting; and C designates communications equipment.

Before proceeding to an explanation



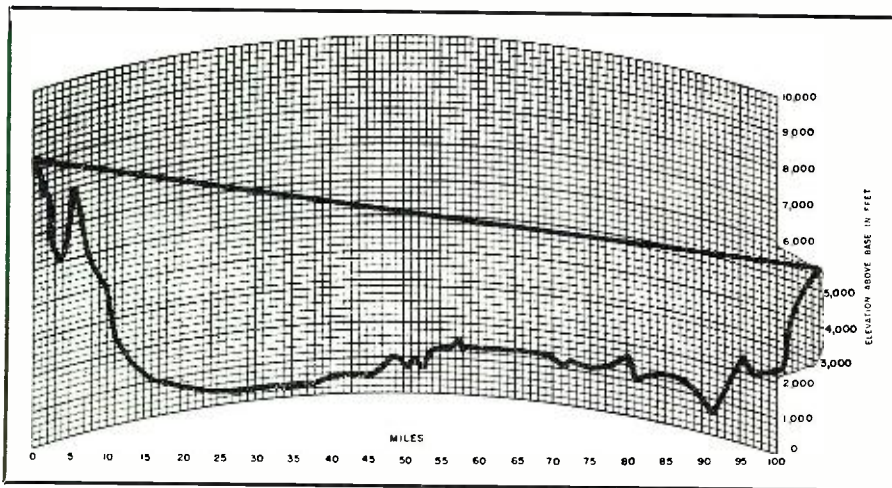

Earth cross-section used to determine transmission path. The straight line indicates line-of-sight path between Mt. Frazier (left) and Blue Ridge Lookout (right).

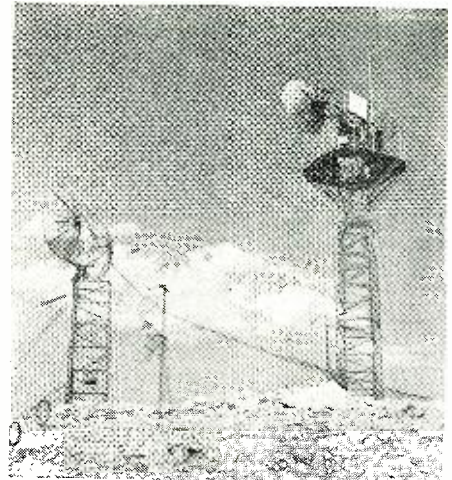

Four different sets of radio relay antennas in operation on Santa Catalina Island.

of the equipment, it should be noted that since late spring of 1945, Signal Corps engineers have been conducting comparative tests of this equipment to determine relative efficiency and so on. California was selected because of the availability of a variety of terrain and climatic conditions comparable to those of the Pacific, the islands and the mountains of the Asiatic mainland. Sites selected were Fort MacArthur, Mount Orizaba, Catalina Island, Mount Frazier, Blue Ridge Lookout, Mount Hamilton, Presidio of San Francisco, and Mount Soledad. All four types of sets are being operated over the same paths, with these ends in view: (1) to obtain information regarding the effects of various atmospheric conditions, called anomalous propagation; (2) to obtain information regarding problems of transportation and supply; (3) to determine ease of installation, operation, and maintenance of equipment; (4) to determine how many relay stations can be used in a system before the system is no longer satisfactory from the stand-

points of quality and reliability; and (5) to learn the effects of aircraft flying in the paths between radio sets.

The California set-up employs all four sets mentioned, operating them in four parallel circuits containing four relay stations over a total radio distance of 510 miles. Three jumps are over 100 miles long, one being 170. One of the chief tasks has been correlation of meteorological data with equipment performance. Had the war continued, the California studies would have provided vital information leading to improved use of radio relay in the field. With victory the viewpoint has shifted. Now data obtained in California is being used by the occupation forces in Europe and the Orient and by the Signal Corps Engineering Laboratories to keep our armed forces "in front" in having available the world's best military communications.

AN/TRC-1 is a frequency-modulated set, operating in the range of 70-100 megacycles with wavelengths between 3 and 4.3 meters, or roughly ten feet.

Radio relay equipment in use at Fort McArthur, showing officer monitoring the circuit. The equipment in the trailer will provide simultaneously a maximum of 24 voice circuits, any one of which may be used for six teletypewriter circuits.

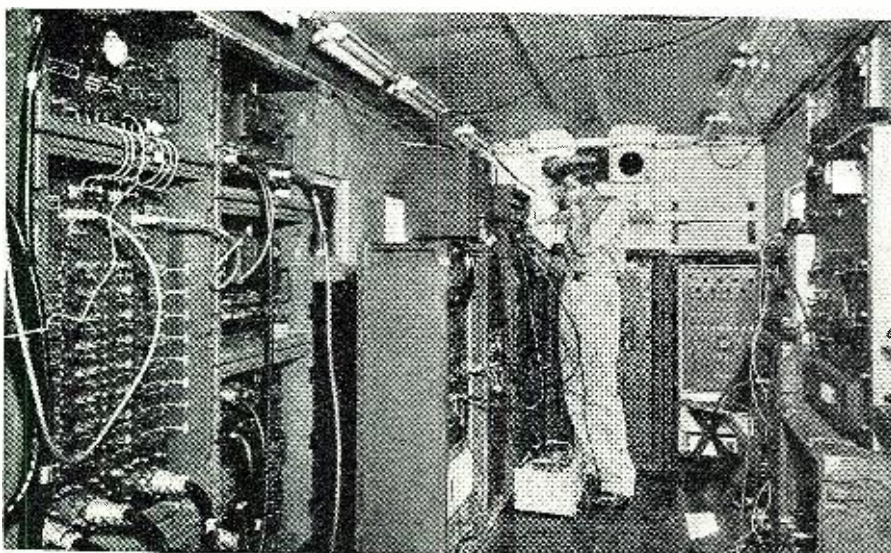

The antenna is of the simple double-HI type—three arms mounted horizontally. The director arm is located on the side pointing toward the next station, with the radiator in the center and the reflector on the rear. The transmitter with its case weighs 108 pounds, the receiver 88 pounds. Transmitter output is 50 watts. The set provides a high-quality circuit to which is connected telephone terminal equipment providing four simultaneous telephone circuits. Normally, six men can keep this station operating on a 24-hour schedule, after having put it into operation within two hours after reaching a location.

Each transmitter and receiver is equipped with sixteen crystals, eight in the 70-80 megacycle range and eight in the 90-100 range. These basic frequencies were so chosen that no transmitting frequency in one range will interfere with any receiving frequency in the other range. At any station, the transmitter works on one range while the receiver operates on the other.

It should be remembered that this set is designed to provide point-to-point circuits over relatively short distances (about 25 miles) when used singly, or over extended ranges (up to 100 miles) by means of automatic relay stations. The range of operating frequencies is high enough to take advantage of the almost complete absence of atmospheric noise and disturbances, particularly static. Also, at these frequencies (70-100 megacycles) a considerable amount of security from unauthorized reception is given because the signals are roughly limited to line-of-sight paths. By the use of frequency modulation, a high signal-to-noise ratio and freedom from man-made noise interference are obtained.

The equipment has been specifically designed with a high-fidelity audio-frequency characteristic to permit the relaying of multi-channel telephone circuits such as those developed for use with the so-called "spiral-four" carrier telephone cable. In this system four simultaneous conversations may be held over a single spiral-four



cable or over a single radio channel. The four channels occupy an audio-frequency spectrum of 200-12,000 cycles. Channel 1, occupying the range 200-2800 cycles, is transmitted as a normal telephone circuit. The three remaining channels occupy the frequencies between 3000 and 12,000 cycles, and are transmitted as single band, suppressed carrier circuits. The signals transmitted over the multi-channel system are such that, if intercepted, only a meaningless jumble of sound could be heard! Since Channel 1 might be understood, it is normally used only for checking and servicing purposes. This station may be used as either a terminal or a relay. When used as a relay station the signals from a distant transmitter are received, amplified, and applied to the input of another transmitter, which relays the same multi-channel signals to the next station without change.

The transmitter is frequency-modulated, using the phase shift method of obtaining frequency deviations. Use of the phase-shift method allows direct crystal control of the mean carrier frequency, a necessity in unattended and portable equipment. The receiver operates on any single pre-set channel in the 70-100 megacycle range and is designed to receive FM signals having a maximum deviation of  $\pm 30$  kc. It employs sixteen tubes in a crystal-controlled double conversion superheterodyne circuit.

It is of historic interest to note that AN/TRC-1 played a large part in our invasion of France, both initially and during later operations. The cross-channel circuit was first used to transmit a single voice circuit or a single facsimile circuit. In the latter case the facsimile equipment transmitted vital "air-recon" information from headquarters of the Ninth Tactical Air Command in England to First Army invasion forces on Omaha beach. Later, multi-channel telephone terminal equipment was installed in England and France and at the relay station on the Isle of Wight to provide several telephone and teletype circuits. Still later these sets, 10,000 of which had been purchased by the Signal Corps before the war ended, performed yeoman service in the Pacific from ship to shore and from island to island. It was over AN/TRC-1 that General MacArthur's famed "I have returned" was broadcast to the Philippines.

AN/TRC-8 is similar in operation, characteristics, and performance to AN/TRC-1. It is a frequency-modulated set operating between 230-250 megacycles and is capable of supplying four high-quality simultaneous telephone circuits. Slightly larger than the first named, the transmitter weighs 135 pounds, the receiver 126. Six of these sets were sent to the European theater in 1944, where they were first used by the First Army. Operation in tactical relay circuits proved very satisfactory. Important was the fact that this set proved more simple to operate than the AN/TRC-1

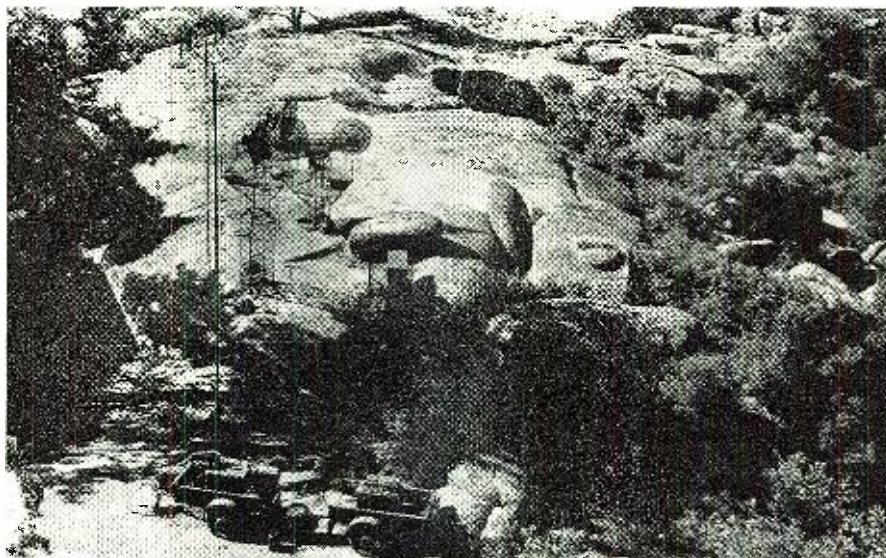

Radio relay installation at Blue Ridge Lookout, near Porterville, California, elevation 5680 feet. This station relays 24 voice circuits in two directions.

and provided communications in a hitherto unused band.

The antenna resembles a double wire gate, the two gates being hinged and serving as reflectors, with a dipole assembly suspended between the gates. The transmitter is a resonant-line reactance oscillator operating at one-third of the desired frequency, driving a power amplifier which operates as a frequency tripler. The carrier is frequency-modulated and the power output is approximately 12 watts. Both high-fidelity and low-fidelity speech frequencies are fed into the audio amplifier stage. The oscillator tube is controlled by the frequency control line (a temperature-compensated transmission line) providing the required frequency stability. Coupling loops from the reactance modulator and tripler tubes also terminate in this line. Output of the reactance modulator tube shifts the oscillator frequency from its nominal value by

changing the reactive current value present in the frequency control line.

The oscillator frequency is adjustable from 76.7 to 83.3 megacycles by the frequency control dial. The tripler stage operates at the third harmonic of the oscillator frequency and delivers a final frequency of 230 to 250 mc. An r.f. output rectifier tube and meter in the output position are connected across the transmitter output circuit. The meter indicates proper tuning, since its reading is proportional to the r.f. output. One tube, half of which amplifies a portion of the speech frequencies, which then are rectified by the other half, serves as a per-cent modulation indicator. The rectified output is measured by a meter, which is calibrated to indicate percentage of modulation.

The receiver is a 15-tube superheterodyne designed to receive FM signals with a frequency deviation of 100 kc. The antenna is coupled to the

AN/TRC-6 radio relay equipment installed in tent at Blue Ridge Lookout. This set represents a new departure in the field of radio communications. The set employs "pulse-position modulation with time division multiplexing."

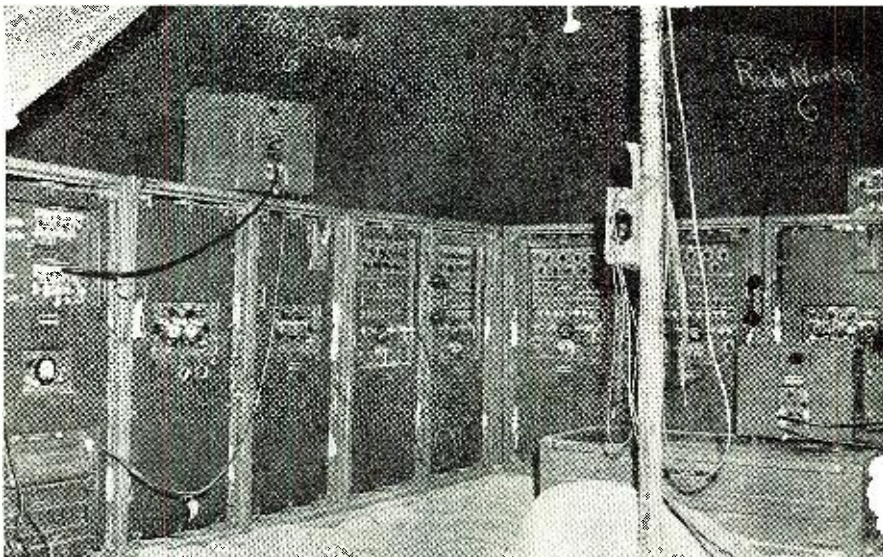





Radio relay terminal at Presidio, San Francisco. Equipment truck and supply tent may be seen in the foreground.

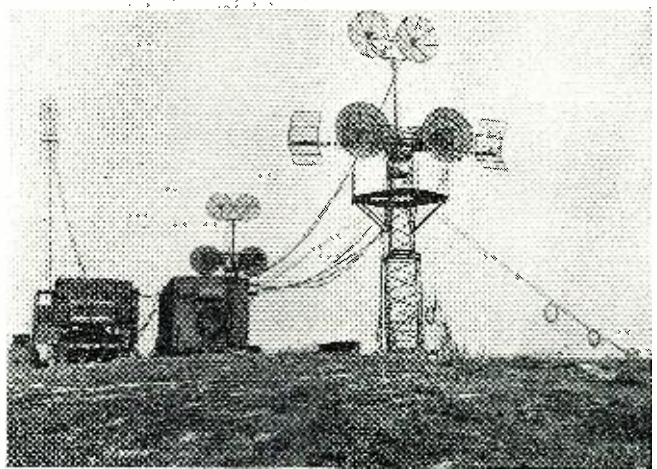

A single antenna tower supports three sets of radio relay antennas for a mobile station near Fresno, California.

receiver by a coaxial line. Signal from the output of the r.f. amplifier tube is coupled to a mixer tube. An oscillator tube produces a local oscillator voltage 30 mc. lower than the signal frequency. This voltage is combined with the received signal in the mixer stage to produce a difference frequency of 30 mc. Most of the gain and selectivity occurs in four i.f. stages, output of the fourth stage being fed into the first and second limiters. These limiter stages remove any amplitude modulation, such as noise, so that a signal of constant amplitude, varying only in frequency, is applied to the following discriminator stage. The discriminator demodulates the signal, and two audio-amplifier stages follow the discriminator. Output of the first audio amplifier is fed into a spiral-four cable at a terminal station, or into a transmitter input at a relay station. This is considered the high-fidelity output. The

other half of the tube operates as a second audio amplifier. A low pass filter, which removes all frequencies above 2800 cycles, permits only low-fidelity signals, 200 to 2800 cycles, to be heard.

AN/TRC-6 represents a new departure in the field of radio communications. When the development of the AN/TRC-6 was undertaken, it was decided to include in the radio set the multi-channel facilities desired, but without the use of extra telephone equipment. The result was a set which employs "pulse-position modulation with time division multiplexing."

By "pulse-modulation" it is meant that the radio frequency waves are sent out in short bursts rather than continuously as in amplitude or frequency modulation. In pulse-position modulation the pulse which transmits the intelligence (speech, teletype, or facsimile) repeats at a regular rate,

so that periodic sampling of the intelligence to be transmitted takes place. When the intelligence is applied, the pulse's time of occurrence is correspondingly varied in position and time. Hence the name "pulse-position modulation." Thus in pulse-position modulation the radio transmitter is turned on for extremely short periods of time (one-millionth of a second) and the intelligence to be transmitted determines the time at which these pulses occur.

In AN/TRC-6, eight separate pulses are used, and the time of occurrence of each is varied in accordance with the intelligence transmitted from one of eight separate channels. No two pulses are allowed to occur at the same time; i.e., they are interlaced. Thus, eight telephone circuits are available for simultaneous use. Each of these circuits may be connected to conventional telephone lines. If de-

(Continued on page 151)

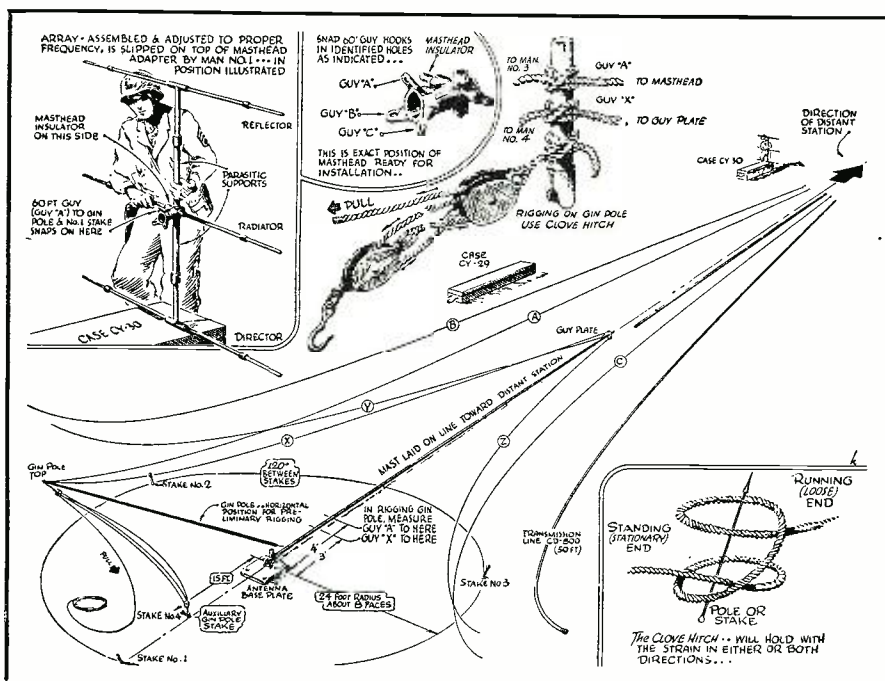

Ground plan and parts layout that is followed in the assembly of portable antenna system AS-19/TRC-1.

Completely assembled antenna system AS-19/TRC-1. This antenna is light in weight and is of the double-H type.

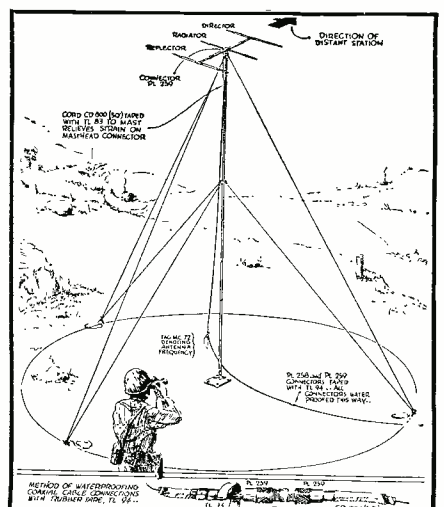



# RADIO OPERATED AIRPLANE

By S. R. WINTERS

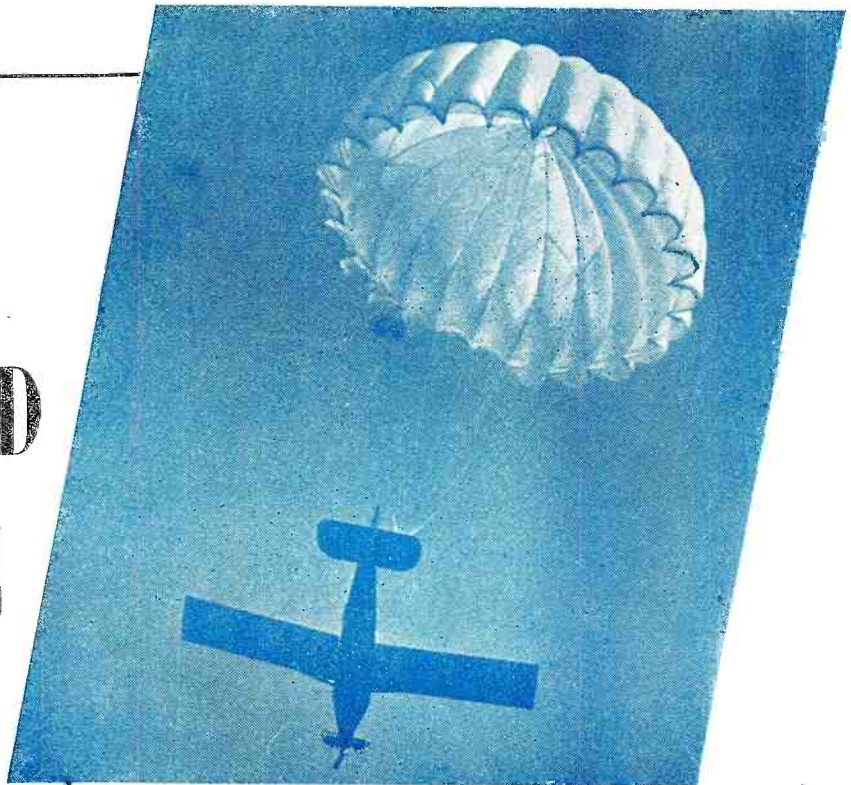

Mission completed, the radio-operated plane gets a comfortable ride to earth by parachute. The pilot on the ground releases parachute from fuselage via radio pulses, automatically killing the plane's motor.

At the remote-control joy-stick of a radio-controlled plane is an antiaircraft officer. By varying the controls, he can bank, loop, and dive the plane to make tracking tough for ack-ack batteries firing live ammunition.

***Radio-controlled planes, the dream of many prewar experimenters, have stepped out of the novice field.***



**T**AKING off, zooming through the skies at a pace of 125 miles an hour, going into dives and banks, and then landing by parachute—performing all these maneuvers solely by means of radio, is a pilotless airplane of the American Air Forces Center at Orlando, Florida. Without a person on board, not only is this unique flying craft guided by ultra-high-frequency radio waves, but its 8-horsepower engine is killed automatically when the plane's landing parachute is caused to spring out of a trapdoor.

As a forecast of pilotless civilian airplanes, when radio waves will start, steer, and land flying craft, this innovation may also be an immediate forerunner of radio-powered planes. In its present phase of being controlled by radio, this miniature plane, with a 12-foot wing span and resembling an overgrown model airplane, utilizes an ultra-high-frequency carrier, which is modulated by five different audio frequencies. Of this number, four frequencies are selected by a stick in the

*(Continued on page 158)*

A catapult is used to project the plane into flight. An officer is shown making preliminary adjustments on plane in preparation for flight.

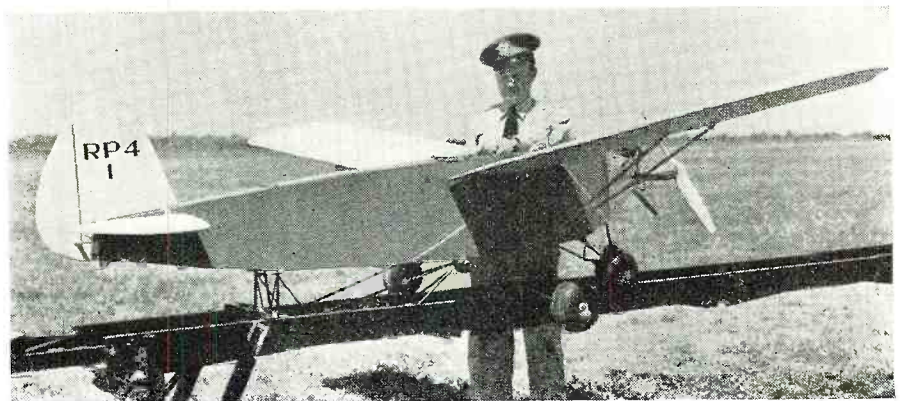



# FM in CANADA

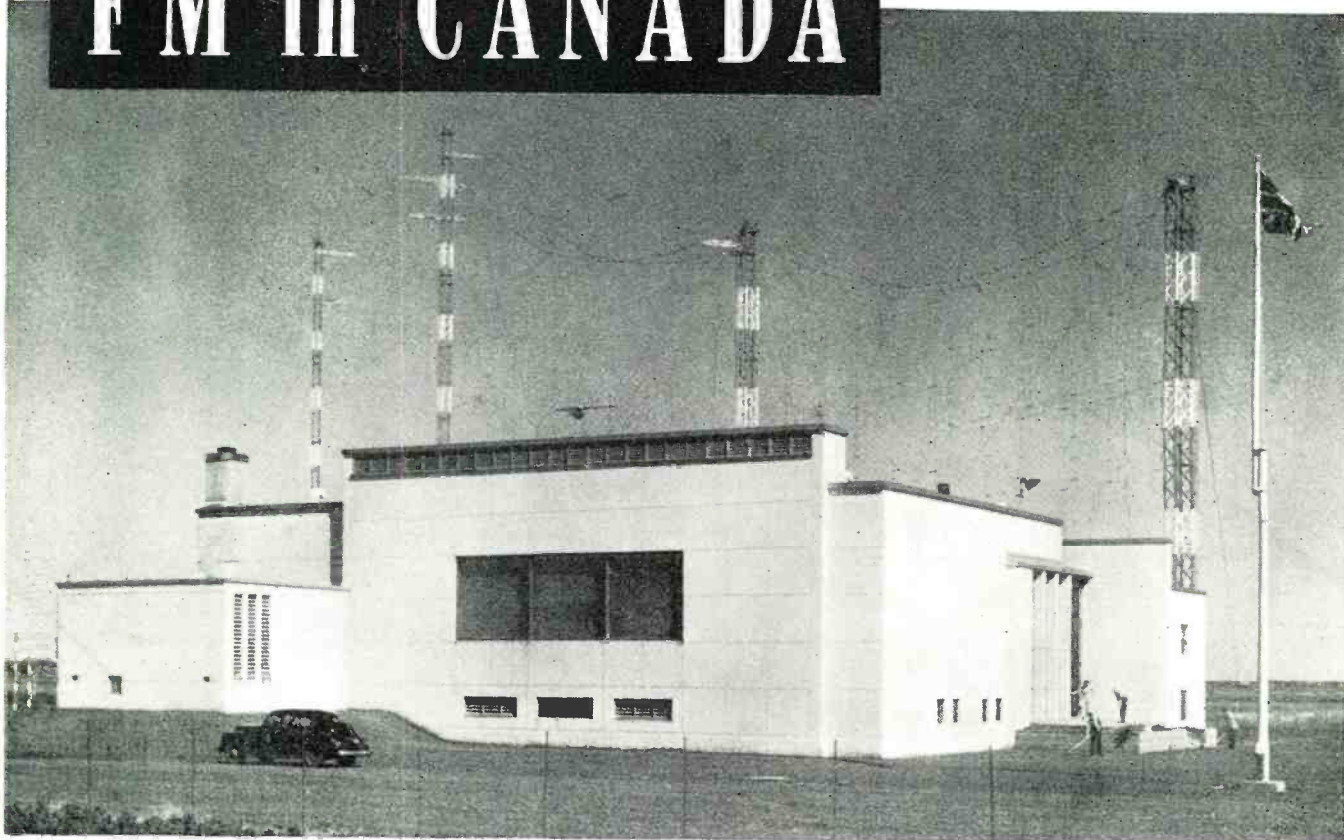

Transmitter building located at the new CBC International Short-wave Service at Sackville, N. B. This building also houses the 50-kw. transmitter for CBA, which is Canada's regional station for the Maritimes. The CBA antenna is to the left of the building shown in the photograph, but the tower itself cannot be seen. The antenna behind the building is used exclusively for the Short-wave Service.

**Highlights of the many controversial problems that confront radio broadcasters in Canada.**

Station CBL, the 50-kw. regional station for Ontario. The transmitter is at Hornby, Ontario, about 25 miles from Toronto.



By DOROTHY HOLLOWAY

**A** BEHIND-THE-SCENES power fight is quietly shaping up over FM north of the border.

Principal contenders are Canada's ninety *private* broadcasters, already on the defensive against what they believe is a move by the Canadian government for still more control over radio, and the Canadian Broadcasting Corporation, spurred on by U.S. activity in FM and what looks like a tight frequency supply along the Great Lakes and northern New York boundaries.

While the Canadian government wants to nail down an FM policy quickly and to press for immediate negotiation with the United States for an allocation of FM channels along the border, the private licensees are playing for time.

Primarily, the private operators fear that Dominion radio authorities may force them into FM before they are ready for the change-over. At the same time they register almost 100 per-cent opposition to any Canadian Broadcasting Corporation policy which might confine *private* operations to the FM field, leaving the government in complete control of the powerful 50-kw. clear-channel and regional outlets

which provide service to the entire country.

Meanwhile, Dominion radio authorities are casting a wary eye southward at an already clearly defined U.S. policy in FM and an allocation which promises to absorb a lion's share of the border frequencies. Their goal is definitely an FM policy for Canada by the first of the year.

The whole picture—under an earlier commitment of the Canadian Broadcasting Corporation to private industry—is slated for a partial airing at a meeting called by CBC to discuss details of an FM allocation. The next step requires approval of any allocation plan by the Department of Transport, which handles the technical end of radio regulation. In any event it will be impossible for Canada to climb aboard the FM bandwagon much before year-end.

Meanwhile, however, the CBC's six-man board of governors has not been idle. A confidential policy memo, under wraps in Canada, lays down tentative policies for FM, certain to meet obstreperous opposition from Canada's private licensees.

Highlights of the CBC proposals are:



1. Canada should adopt the same band frequencies for FM as used by the United States. This is, of course, the 100 channels from 88 to 108 megacycles, of which the U.S. has earmarked 20 bands for use of non-commercial outlets.

2. Steps should be taken to protect Canadian interests in FM channels by the immediate negotiation with the U.S. for a division of channels along the border.

3. The number of FM stations permitted in a given area shall in general be limited to the commercial possibilities of the region. (The CBC has definitely taken the position that "too many FM stations would result in cheap broadcasting." The author of the proposal makes the point: "The method I suggest would justify us (the CBC) to demand reasonable service from all stations, as competition would not be as keen and chances of making reasonable profits would be better." This same policy, under the CBC proposal, would apply to standard as well as FM operations.) A formula will be worked out, defining the number of stations any one area can reasonably support.

4. However (and this proposal will be anathema to private licensees), CBC stations, because of the fact that they do not carry commercial spot announcements and local commercials and are "primarily interested" in regional coverage and network operation, may be added anywhere above the number permitted under 3, above.

5. An FM frequency would be given to any present standard station licensee provided (a) that any time after June 1, 1948, the station could be given a year's notice that it must abandon AM and operate exclusively on FM; and (b) that any FM station operating in conjunction with an AM station "must carry all and the same programs at all times except where a sustaining musical program can be produced for high-fidelity transmission by FM." (The implication here is that CBC approval will be necessary for any broadcast of non-duplicated FM programs, a more or less complete reversal of earlier FCC policy in the AM-FM programming field.)



A typical CBC mobile unit. This particular unit is located at Montreal, but similar ones are located at various CBC production points throughout the country.

6. New applicants for stations will be permitted to operate on FM provided the power and location of the station fits in the allocation plan. (In fact, the CBC member's proposal goes farther. He writes: "Generally speaking, there should be an attempt to use FM for any new application when equipment and receivers are available and widely distributed, *except where AM is essential.*" AM would be essential only where wide coverage is desired, and presumably CBC stations will fill this need under present government goals.)

7. All new FM stations must operate according to a regular schedule for a minimum period of time daily as approved by the CBC.

8. Details of allocation methods will be determined after consultation with the Department of Transport and private industry.

Some parts of Canada, like the U.S., have already reached the saturation point in the standard broadcast band. The CBC memo emphasizes that it is "almost impossible to find a frequency that can be used in southwestern Ontario even with directional arrays to shield stations operating in the U.S."

Clue to CBC thinking in FM is a statement in the memo suggesting that by a proper FM allocation, congestion would be relieved in the standard band and more clear channels could be used for high-power regional service. Private broadcasters see here a thinly veiled move by the Canadian government to confine them to a local and community service in FM, which, under the policies outlined above, would

place them in an even more subsidiary role to the dozen powerful government stations which do the coverage job. The CBC owns and operates all of Canada's 50,000-watters and its stations are generally the highest-powered on the air. In addition, the Government owns, operates, and programs both of Canada's networks, with complete sovereignty over network programs of all kinds.

Glenn Bannerman, president and general manager of the Canadian Association of Broadcasters, prototype of our own NAB, takes the firm position that "the CBC should wait at least five years, until we see what FM can do and have had some actual operating experience, before blueprinting any hard-and-fast policy. FM in its pioneer stages should be left with as few strings as possible."

Private broadcasters "simply won't stomach" the idea of relinquishing their AM channels for FM on any arbitrary date without the benefit of practical experience in the field, Bannerman asserts.

The CAB president also points out that, outside of a CBC FM station in Montreal, there are only two privately operated experimental FM outlets—CFRB, Toronto, and CFCF, Montreal. Ironically, there are only five registered FM sets in the whole Dominion.

Bannerman adds: "I don't like the look of any plan whereby the CBC will limit private broadcasters to FM. That way, they could shut out network operation from any but government stations." Although he was not familiar

(Continued on page 140)

Control room at Vercheres in the CBF transmitter building. This studio is representative of many others found in Canada.

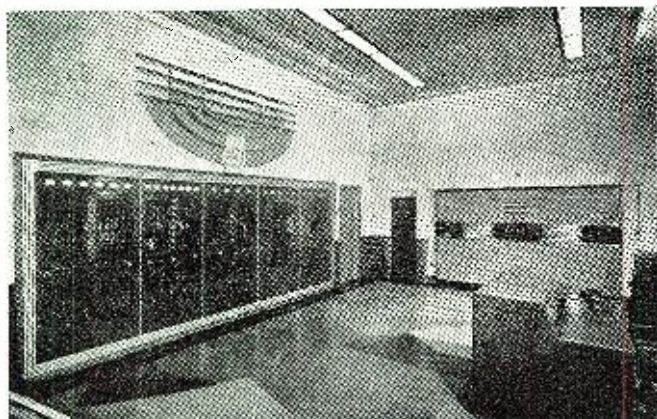

A CBC prewar studio design. The one shown in the photograph is studio "H" located at the Montreal production center.





Fig. 1. This group of absorption wave-meters covers a frequency range of 50 kilocycles to 148 megacycles.



Fig. 2. Special u.h.f. fixed crystal detector employed in microwave frequency meters.

# Introduction To U.H.F. FREQUENCY MEASUREMENTS

By GUY DEXTER

***As amateurs utilize progressively higher frequencies they will encounter many new problems and techniques.***

**S**EVEN of the higher-frequency bands set aside for postwar amateur communications lie above 150 megacycles. They are 220-225 mc. (1.33-1.36 meters), 420-450 mc. (66.7-71.5 centimeters), 1145-1245 mc. (24.1-26.2 cm.), 2300-2450 mc. (12.25-13.05 cm.), 5250-5650 mc. (5.32-5.72 cm.), 10,000-10,500 mc. (2.86-3.0 cm.), and 21,000-22,000 mc. (1.36-1.43 cm.). The widest of these is the 21,000-22,000 mc. band, which has a 1000-megacycle spread. The entire allocation represents a territory of 2185 megacycles in which the amateur will be required to know his frequencies with reasonable accuracy.

Some prewar hams cut through as far as 400 mc. before the shutdown. But to the rank and file these new frequencies are *terra incognita*, and half the fun of opening up above 225 mc. will be discovering how to generate and measure such extremely high frequencies. As fast as official restrictions on wartime technical information are removed, we intend to offer our readers *specific* circuit data for very-high-frequency transmitters, receivers, and frequency meters. In the meantime, we aim to give in this article an over-all picture of the new frequency measuring requirements and to describe as understandably as possible some of the special apparatus which already is being used by non-amateur services.

On lower transmitting frequencies the ham has been inclined to depend

entirely upon crystal frequency ratings. Unless he has employed s.e.o. excitation or *band-edge* crystal control, he has not been too disturbed about carrier frequency measurements. And in general he has been reasonably safe. The picture is altered on the extremely high frequencies by the fact that beyond the 220-225-mc. band, crystal control will not be entirely practicable. The frequency of self-excited oscillator circuits employed in the ultra-high and super-high-frequency regions must be checked, even when some form of stabilization, such as linear or concentric tank circuits, is employed.

The ham will have important neighbors on the sides of each ultra-high-frequency band. These will include government, navigation and air navigation aids (undoubtedly radar), television relay, and non-government fixed and mobile services. He must not disturb these services by out-of-band operation. He will find that, as far as these new bands are concerned, the frequency standards and meters, wavemeters, and monitors he built for the 10-160-meter spectrum are of negligible *direct* value. And if he has not followed u.h.f. progress during the war period, he will find that lower-frequency design and construction tech-

niques will not yield practicable and dependable frequency measuring gear for the microwaves.

The following sections will compare the established systems with which the ham is thoroughly familiar, with the systems that are more favorable to the ultra-highs. We have purposely avoided weighty mathematical and physical discussion, preferring to unveil the picture and to list references for the rugged souls who care to go farther. We have selected two commercial v.h.f. frequency meters for discussion because we feel certain that ham instruments will follow their design.

## Earlier Systems

All carrier frequency measuring instruments may be grouped into two classes, heterodyne and non-heterodyne. The non-heterodyne types are the simplest and least accurate. Heterodyne types include frequency meters and monitors. Familiar non-heterodyne types are absorption wavemeters and Lecher wire systems. Instruments in both classes are familiar to radio amateurs.

*Wavemeters.* Little difficulty has been experienced in obtaining simple coil-capacitor wavemeter operation be-



tween 100 kc. and about 150 mc. At the higher end of this wide range, capacitance of the coil and inductance of the tuning capacitor become an appreciable part of the tuning circuit  $L$  and  $C$  and must be figured into the design. The effect of this extra  $L$  and  $C$  is to lower the highest frequency which may be reached by the wavemeter and to narrow the tuning range. Simple wavemeters of conventional design and arrangement accordingly are not generally employed beyond about 150 mc. Fig. 1 shows a group of simple coil-capacitor wavemeters for covering the range 0.1-148 mc. The separate wavemeter ranges overlap. A well-known example of a single direct-reading wavemeter, equipped with plug-in coils for the 0.5-150-mc. range is the *General Radio* Type 566-A.

**Lecher Wire Systems.** In prior practice the Lecher wire system has taken up where the simple absorption wavemeter has been compelled to leave off. The basic arrangement of Lecher wires is illustrated in Fig. 4. The two stiff, parallel wires or rods,  $A$  and  $B$ , are rigidly supported one or two inches apart. At one end the wires are continuous to form a half-turn "hairpin" coupling loop, which is coupled to the oscillating circuit under test. A short-circuiting bar, which may be slid along the entire length of the wires, is broken at its center to include in its own circuit an indicating device. The latter may be a thermoammeter, thermogalvanometer, flashlamp, glow lamp, or similar r.f. indicator. Some Lecher wire systems make use of a solid bar without an indicator. In such case the indication will be obtained from certain response of the receiver, transmitter, or test instrument to which the wires are coupled. In operation, the loop is loosely coupled to the source of unknown frequency and the shorting bar is moved along the wires until the indicator shows a node. The bar then is slid farther along to discover a second node. The distance, measured in inches or centimeters, between two successive nodes indicates the half-wavelength of the unknown signal. This wavelength may be converted into megacycles. The chart given in Table 1 automatically converts inches into megacycles. This chart has been set up for the new amateur v.h.f. and u.h.f. bands, starting at 220 mc.

An examination of the chart will reveal immediately the practical limitations imposed upon extremely-high-frequency Lecher wire systems. Note that the distance the shorting bar must move between node points along the wires becomes impracticably short in the higher-frequency bands. In band  $A$ , the total travel of the bar to cover the entire band is a little more than  $\frac{1}{2}$  inch; in band  $B$ , just under 1 inch; band  $C$ , less than  $\frac{3}{8}$  inch; band  $D$ , slightly more than  $\frac{5}{32}$  inch; in  $E$  and  $F$ , much less than  $\frac{1}{8}$  inch; and in  $G$ , less than  $\frac{1}{64}$  inch.

**Heterodyne Frequency Meter.** The

general arrangement of the familiar heterodyne frequency meter is illustrated by the block diagram, Fig. 8. In this circuit a signal of unknown frequency is delivered to an aperiodic mixer or demodulator where it is combined with signal voltage from a tunable, calibrated oscillator. The mixer is tuned only in special applications. The system will check frequencies that are fundamentals, harmonics, or sub-harmonics of the local oscillator frequencies. It has been standard amateur practice to operate the local oscillator in a band integral with or lower than the lowest-frequency band in which unknown signals are to be measured. Thus, a heterodyne frequency meter for all-band ham use took the prewar form of an oscillator operated in the broadcast or 160-meter band.

The beat note resulting from mixture of known and unknown signal voltages is amplified in a suitable a.f. section and presented to a zero beat indicator. This type of instrument affords good accuracy when its design is refined, but seldom is practical for measurement of frequencies beyond about the 20th harmonic of the calibrated oscillator frequencies.

High-frequency limitations are imposed upon the simple heterodyne frequency meter by (1) the highest frequency at which tunable oscillators of satisfactory frequency range and stability may be operated, and (2) electron-transit time effects which limit the maximum frequency at which a simple v.t. mixer or demodulator may be operated.

### High-Frequency Developments

**Wavemeters.** The absorption wavemeter has been further refined to project its practical range into the 200-1000-mc. region. A few experimental instruments have reached several thousand megacycles. Several designs have appeared in which rotation of the tuning capacitor rotor plates causes a sliding contact to move along a heavy fractional-turn band-type coil, thus varying inductance simultaneously with capacitance. The capacitor and coil portions are assembled to form a

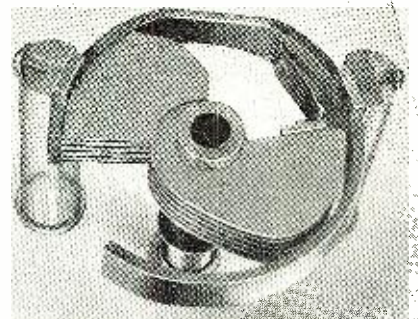

Fig. 3. Contact-type tuning unit used for 60 to 660 megacycles.

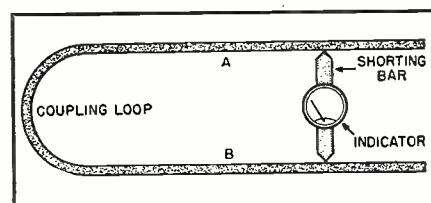

Fig. 4. Lecher wire system.

parallel resonant circuit (series resonant in true wavemeter action). In wavemeters of this type, an ingenious integral assembly of the capacitor and coil minimizes the stray  $L$  and  $C$  components in the circuit. Fig. 3 shows an arrangement of this type employed in the *General Radio* 60-660-mc. tuning unit. Here the capacitor stator is connected (by assembly) to one end of the inductance band, and the sliding contact, wiping the inside of the band, is attached to the rotor plates. An extension of the same principle makes possible coverage of the 400-1600-mc. spectrum with another type of *General Radio* wavemeter. Other special u.h.f. wavemeters employ the butterfly circuit.

**Butterfly Circuits.** In order to eliminate the wiping contact, *General Radio* developed the "butterfly circuit." In this arrangement, inductance and capacitance are varied simultaneously by means of what would appear to be only the capacitor rotor.

Fig. 9 shows a butterfly condenser of the type used extensively for resonant circuits in the v.h.f. and u.h.f. ranges. The stator plates consist in

Fig. 5. Illustrating the mechanical construction of resonant cavities.

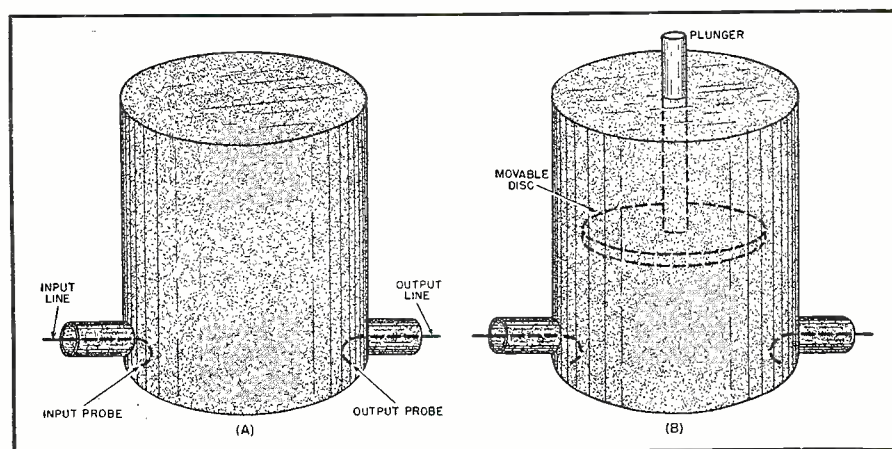



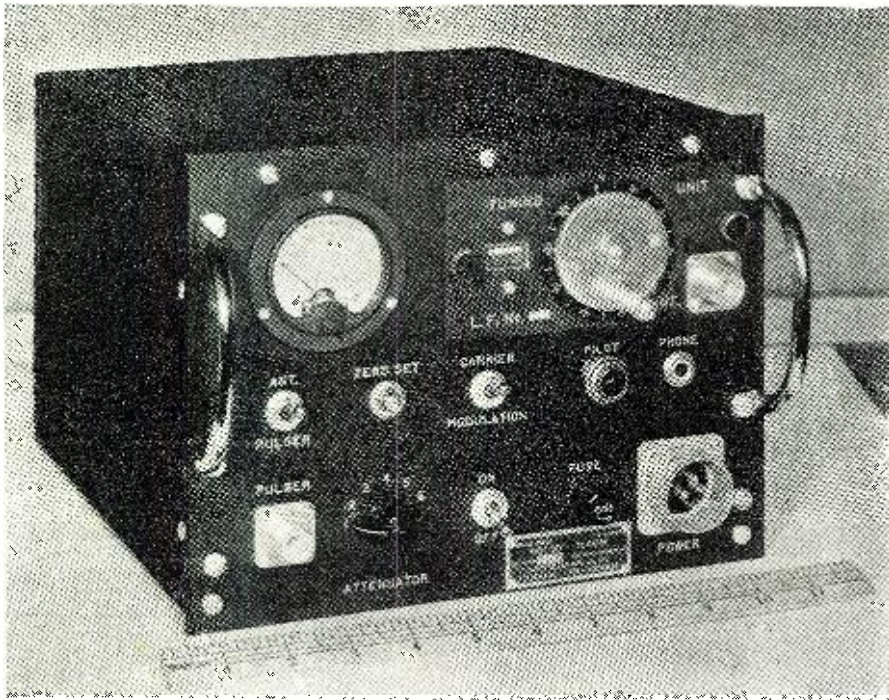

Fig. 6. Front view of the Millen v.h.f. frequency calibrator.

effect of two stator fins connected together by semicircular bands. The bands supply the inductance. The rotor plates are shaped like a butterfly, hence the name. This simple arrangement thus is a coil-variable condenser circuit in which inductance is also varied.

Circuit inductance is lowest when the rotor is in the position shown in Fig. 9. It is highest when the rotor plates are interleaved with the stator plates. Circuit capacitance likewise is lowest when the rotor occupies the position between the stator fins, as shown in Fig. 9. An inductance change as great as  $3\frac{1}{2}$  to 1 may be obtained in practical butterfly circuits. Coupling is effected by placing a small "hairpin" close to one of the "inductance bands." Direct circuit connections may be made on the stator.

While a single butterfly section may be utilized, several similar sections may be stacked (just as variable capacitor plates are) to make a complete butterfly unit. Stacking increases the circuit capacitance and reduces the circuit inductance. Butterfly circuits may be employed as wavemeters as well as in tank positions in u.h.f. instruments. The tuning range of the oscillator section of a heterodyne frequency meter may be extended by sub-

stituting a butterfly circuit for the conventional coil-capacitor circuit. One of the butterfly circuits developed by *General Radio* tunes from 900 to 3000 mc.

**Resonant Cavity.** The principle of the cavity resonator is analogous to that of acoustic resonance in a closed room. This will be familiar to the reader who has noticed how his voice reverberates in a small, tightly closed room. While some *modes of operation* of even a simple cavity may be quite complex to explain, a simple picture is that of very-high-frequency radio energy, injected into the cavity, undergoing multiple reflections (all in the proper phase) back and forth between the inner conducting walls much as sound waves do in a closed room or barrel. The natural resonant frequency of a cavity depends upon the latter's dimensions. However, the size of a resonant cavity is small for high frequencies.

Practical high-frequency cavities are manufactured in various shapes for different applications. The simplest common shapes are cylindrical, spherical, and cubical. Fig. 5 shows two simple cylindrical types which resemble ordinary metal cans. The cavity shown at 5A is a fixed-frequency model, while that at 5B may be varied

in frequency by means of a plunger-driven internal disc or sphere moving between the center of the can and one end. The resonant frequency of a simple cylinder (can) type cavity can be determined approximately by dividing 29,126 by the can radius, in inches. This will be true, however, only for one simple mode of oscillation.

Energy may be injected into and taken from a resonant cavity by means of small antenna probes, inserted into the cavity through concentric lines as shown in Fig. 5A, or simply through properly spaced holes. These are not the only means of excitation, however. For example, wave guides often are used.

Resonant cavities are used as absorption wavemeters or they may be used in place of conventional tuned circuits in u.h.f. instruments, such as frequency meters and oscillators. The cylindrical cavity often is employed as a *frequency standard*, especially when it is temperature controlled.

### Specialized U.H.F. Frequency Meters

*Millen Type 90630.* The block diagram in Fig. 7 shows the arrangement of the circuits in the new Millen Type 90630 frequency calibrator. This instrument covers the 200-700-mc. range by means of two accurately calibrated tunable cavities. Harmonics up to 1500 mc. may be checked with somewhat reduced sensitivity. In this instrument the effects of electron transit time, which limit the highest frequency reached by the best vacuum-tube detectors, have been avoided by employing a high-efficiency *fixed crystal detector*. Fig. 2 is a photograph of this fixed crystal, originally developed for use by the armed services.

When the frequency of a pulse-modulated signal is to be measured, switch *S* is thrown to its left-hand position. The proper cavity is plugged in and tuned to the signal, using the peak voltmeter as a resonance indicator. Crystal detector output voltage is presented to a wide-band (video) amplifier through an input attenuator, and the amplifier output voltage in turn actuates the peak-reading v.t. voltmeter. When the frequency of an unmodulated signal is to be measured, all other operations are the same as just described, except that switch *S* is thrown to its right-hand position, causing detector output currents to flow directly through the d.c. microammeter of the v.t. voltmeter.

An instrument of this type reduces the checking of u.h. frequencies within its range to the simple operation of tuning in the signal and reading its frequency from the dial calibration of the tuned cavity.

Fig. 6 shows a front view of the *Millen* calibrator, with the plug-in variable tuned cavity plainly visible on the right. Fig. 10 shows the two cavities, employed to cover the 200-700-mc. range, removed from the in-

(Continued on page 110)

Fig. 7. Block diagram showing the line-up of the Millen calibrator.

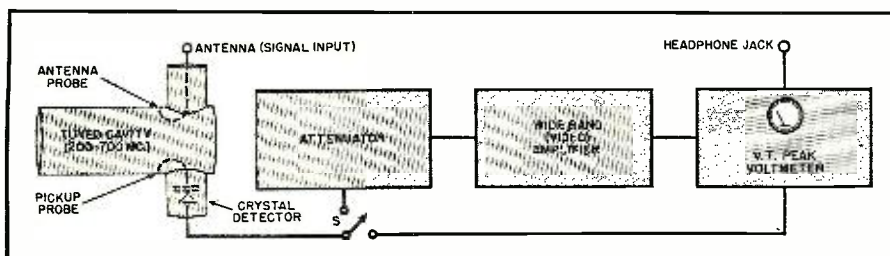



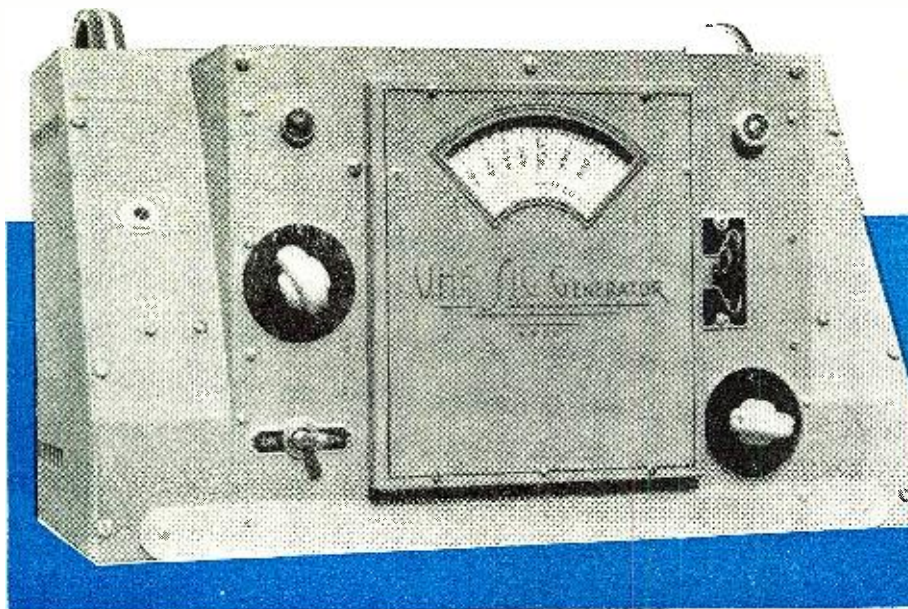

← Fig. 1. Front view of signal generator. The jack mounted on the left is for measuring oscillator grid current. To the left of the dial are, top to bottom, pilot light, modulator tone selection switch, and power supply switch. To the right of the dial, top to bottom, output terminal, dial knob, and attenuator.

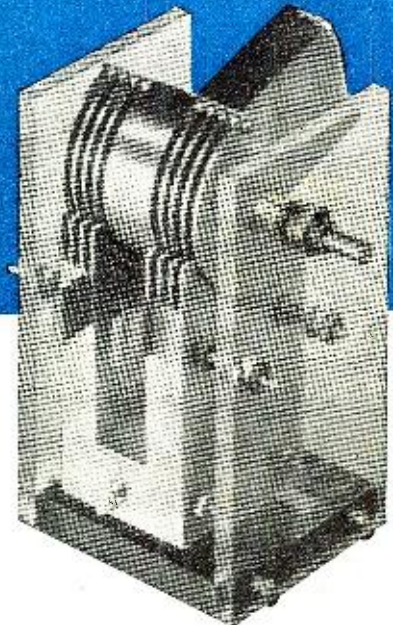

Fig. 2. Close-up of the tank circuit which forms the heart of the r.f. circuit. Unit shown uses a slug not used in the instrument described in the accompanying text.

# 135 to 500mc. SIGNAL GENERATOR

By  
**JOHN WONSOWICZ, W9DUT**  
 and  
**HERBERT S. BRIER, W9EGQ**

*With the trend to higher frequencies, this unit fills the need for an accurate alignment source.*

**S**ERIOUS workers on the u.f.'s often need a signal of known frequency that can be depended upon when making tests and carrying out experiments. This wide-range signal generator fills that need admirably. As can be seen from the diagram, Fig. 3, the circuit is very simple, although there are several tricks involved to get satisfactory results over the entire range of frequencies.

The heart of the instrument is a new tank circuit, a wartime development of the *Pathfinder Laboratories* in Chicago. This tank, with all dimensions, is shown in Figs. 2 and 4. The "slug" extends the range to well over 500 megacycles at the cost of some sacrifice of *Q* on the higher frequencies.

The greatest difficulty in building wide-range equipment is obtaining uniform results on all frequencies. For example, it is often difficult to

get uniform output from an oscillator tuning from one end of the broadcast band to the other. With that in mind the constancy of output from this signal generator can be better appreciated.

Without the slug, the output is constant from 135 to 350 megacycles. Between 350 and 390 megacycles it is down slightly, with the point of lowest output being at 375 megacycles. From 390 megacycles the output slowly increases until the maximum frequency of 465 megacycles is reached. The small variation in output is best shown by the figures on the grid current to the 955. Between 135 and 350 megacycles it is 400 microamperes. At 375 megacycles it drops to 200 microamperes, and at 465 megacycles it is 600 microamperes. When the slug is used the output gradually falls as the higher frequencies are reached, due to the increased losses when the slug is in the field of the coil.

As stated before, the heart of the generator is in the new tank circuit. Full constructional details are given in Figs. 2 and 4. Obviously, any changes in dimensions will result in a change of the frequency range covered. The inside dimensions of the inductance are the most critical. Slight variations in the width or thickness of the legs are relatively unimportant.

The shaft and front bearing are taken from a *Hammarlund* MC series midget condenser. Cut off the shaft about  $\frac{1}{8}$ " in back of the bearing. Then drill and tap the end of the shaft for a 6-32 screw, and thread in a headless brass machine screw  $2\frac{1}{2}$ " long. Drill a hole through the shaft and screw with a No. 55 drill. Through this hole drive a pin to prevent the screw from turning in the shaft. It is essential that the screw be straight and exactly centered in the end of the shaft. If a lathe is available the shaft can be turned down to size and threaded. The rear bearing is a panel bushing with a  $\frac{1}{4}$ " hole. A  $\frac{5}{8}$ " length of the discarded shaft is next cut off, drilled lengthwise, and tapped to fit the 6-32 screw. After the rotor is assembled, this piece is screwed onto the end of the screw and provides the tail-piece which rides in the rear bearing.

All other metal pieces are made



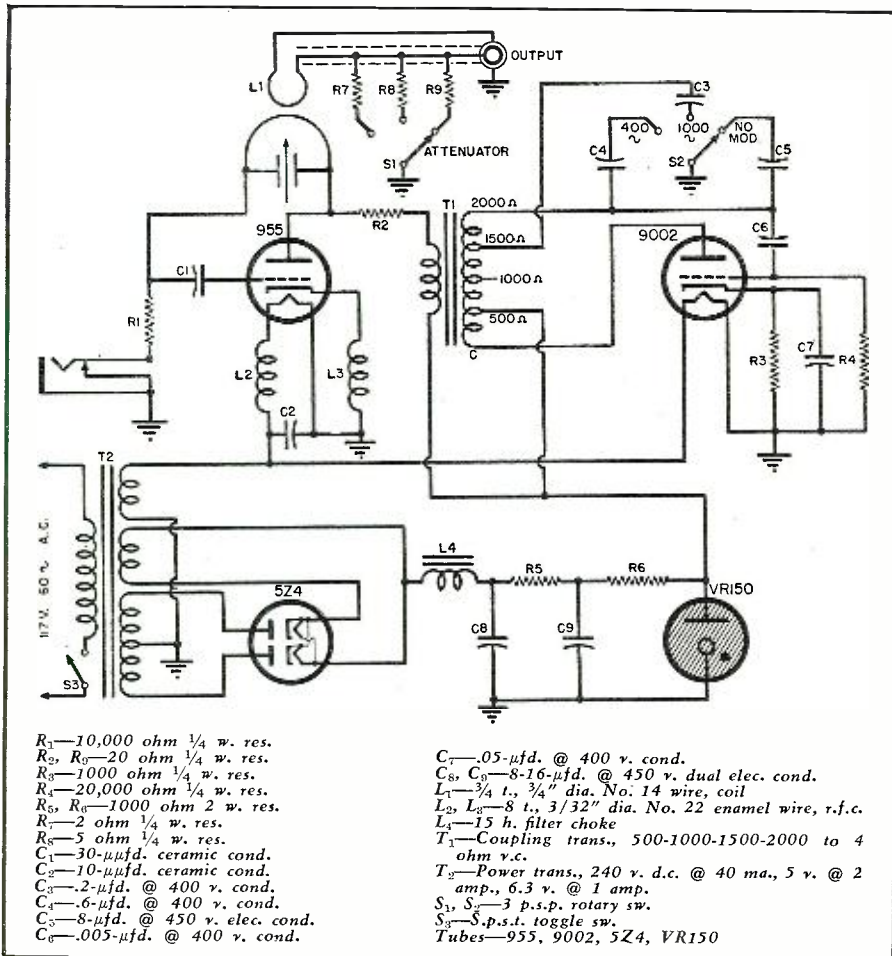
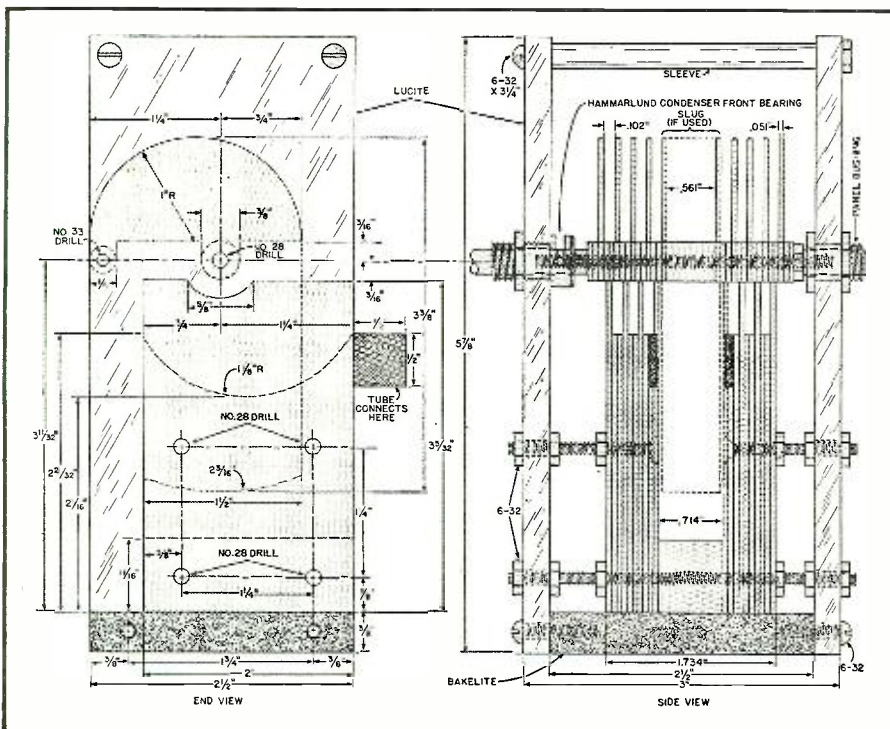

Fig. 3. Schematic diagram of the complete generator showing the simplicity of the circuit.



Fig. 4. Constructional details of the tank circuit used. All parts may readily be made by hand without the use of machine tools. The slug, shown in dotted lines, is used only if it is desired to extend the upper range of the unit from 465 to 500 mc.



from .051" No. 24 ST aluminum. Eight rotor plates are required if the slug is used, ten if it is not. The rotor spacers are ⅜" in diameter, and ten are required. (Each spacer is composed of two thickness of aluminum.) An additional spacer of thick-walled brass tubing .561" long is required if the slug is not used. Eight stators and six stator spacers are required. The bottom spacer consists of 14 pieces 2" x 11/16". The slug is made of 12 pieces held together by countersunk screws tapped into the end pieces. Of course, the slug and bottom spacer may be whittled out of a solid piece of aluminum if desired. The end supports are made of lucite, 5 7/8" x 2 1/2" x 1/4"; and the base is a bakelite block, 2 1/2" x 2 1/2" x 3/8". If the slug is used, it will be necessary to omit the cross braces at the top of the condenser to permit rotation of the rotor and slug.

The reason for repeating "if the slug is used" is that this instrument was finally built without the slug, because it was decided that the advantage of uniform output outweighed the advantage of a slight increase in the frequency range covered.

On the tank 1/2" square tabs are used to compensate for slight variations in characteristics when tubes are changed. At first an attempt was made to use a 1-7 μfd trimmer for this purpose, but that formed a closed loop at certain frequencies, so it was discarded.

The entire r.f. unit, with the exception of the attenuator, is enclosed in an aluminum box 6" x 5" x 5 1/2" with leads for external connections coming out through grommeted holes. The 955 tube socket mounts on the side wall of the box in such a position that there is just enough room between the grid terminal and the tank for the grid condenser, *C*<sub>3</sub>. This also assures the shortest possible plate lead. One filament terminal is grounded directly at the socket, while the other is by-passed to ground through a 10-μfd ceramic condenser. Filament voltage is fed through a small choke made by winding a short length of No. 22 wire around a nail and then removing the nail. A similar choke is used to ground the cathode.

These chokes and the filament by-pass condenser have an important effect on the smooth operation of the signal generator. In tuning such a wide range there is unavoidable phase shift in the tube and leads. Before they were added, there were frequencies where the output and grid current would drop to extremely low values. By adjusting the spacing between turns in the chokes and varying the point where the condenser was grounded, the low spots were eliminated.

The method is this: Tune the oscillator to the point of lowest grid current, then adjust the chokes and the ground position of the condenser until the grid current is normal. Re-



tune the dial and see if the dead spot has been eliminated or only moved. If it has just been moved, repeat the process. By judicious cut-and-try plus a little luck, the dead spots can be eliminated. In this oscillator one compromise had to be made. The output can be increased at 375 megacycles, but then it drops even more at another frequency. Move the ground point of the condenser in very small steps. Sometimes a movement of 1/16" is all that is necessary.

Feeding the high voltage to the plate of the 955 through a 20-ohm carbon resistor also helped to stabilize the output. When it was fed into the center of the tank, the grid current varied between 50 and 800 microamperes as the oscillator was tuned from minimum to maximum frequency. Feeding the plate voltage to the grid side of the tank gave results almost as bad. The 20-ohm resistor is used as an r.f. choke and is much more satisfactory than the conventional inductance because it has no troublesome resonant points to introduce complications. By-passing the B-plus side of this resistor, and the use of a VR-150, further stabilizes the output.

The attenuator circuit used wastes considerable power but has the advantages of simplicity and of making the output terminal quite "cold." Connecting a load, or even short-circuiting the output, causes negligible frequency shift. More efficient attenuators can be built, but they become quite complicated at these frequencies. This one has proved to be quite satisfactory. One possible change would be to use a four-position switch for  $S_1$ , so that there would be one position available with no resistor across it for preliminary tests of new equipment. The attenuator is coupled to the tank through a three-quarter turn coil, 3/4" in diameter, spaced about one-quarter inch from the tank. Considerable variation in output can be obtained by changing the position of the coil with respect to the tank.

Tone modulation is supplied at a low level at 400 and 1000 cycles by a 9002 audio oscillator. It is designed around a 500-2000 to four-ohm output transformer. Using appropriate taps on the primary permits vigorous oscillations, and varying the amount of capacity across the winding changes the tone. The third position of the tone selection switch kills the audio oscillator by by-passing the output signal to ground through an 8  $\mu$ fd. electrolytic condenser. In this way the current drain on the power supply remains substantially constant, whether or not the audio oscillator is on. The plate current for the u.h.f. oscillator flows through the four-ohm winding for modulation purposes. The percentage of modulation is kept low purposely to prevent appreciable frequency modulation. This low level also permits more accurate spotting of frequencies on superregenerative and other non-selective receivers. Heavier

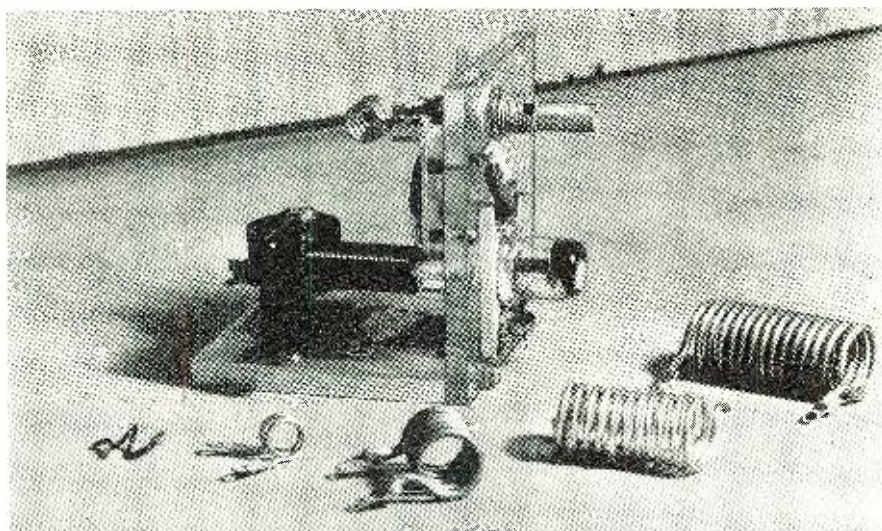

Fig. 5. The receiver and its various coils used for the calibration of the generator.

modulation can be obtained easily by connecting the high-voltage lead of the u.h.f. oscillator to the primary of the transformer.

The choke input power supply is conventional. Nothing in it requires special attention.

An open-ended chassis, 8" x 5" x 2", was sawed in two to make the audio and power-supply chassis. The first is 3 1/2" wide and the other 4 1/4" wide.

The dial is constructed around a *General Electric* No.7761552-GI, 50 to 1 ratio, worm gear dial picked up in an Army-Navy surplus store for fifty cents. It is coupled to the condenser shaft through a pair of 1 to 1 gears, one inch in diameter, obtained at the same place. This allows a five-inch-diameter dial to be used. The dial fastens directly to the condenser shaft by means of a metal collar and two set-screws. It is made of aluminum with a piece of white paper glued to it. The frequency calibration is lettered directly on the paper. A commercial dial like the *National* NPW-O or ACN would make a satisfactory

substitute for this custom-built one. The NPW-O requires a separate calibration chart, while the ACN dial can be calibrated directly. Whatever the type chosen, the dial must be a good one with a large scale and without back-lash if maximum utility is to be obtained from the signal generator.

Using a sloping-front cabinet produces a very pleasing appearance but does make considerable extra work. The various pictures and the sketch show how the panel is cut out and how the false front is added. The cabinet is 14" x 8" x 8".

Calibrating such an instrument is a tedious process unless one has access to an accurately calibrated commercial u.h.f. signal generator, but it can be done by using harmonics of lower-frequency oscillators. Many "all-wave" signal generators give fundamental output up to 60 megacycles or higher, and usable output on higher harmonics. After checking the calibration of such an instrument on its

(Continued on page 114)

Fig. 6. Top view of the generator. The tank circuit and tube may be seen in the shield can.

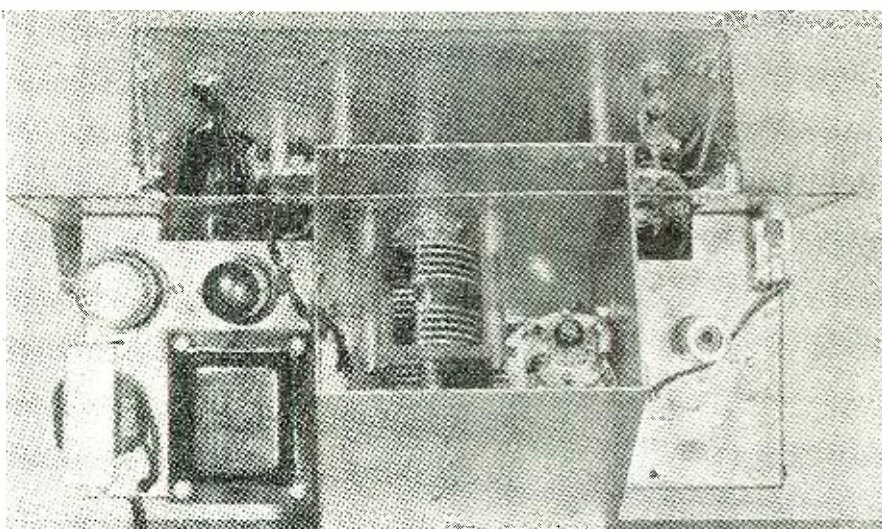



# Improved

By  
**CHRISTIAN A. VOLF**

Director of Research,  
Robinson-Houchin Optical Company



The completed sound reproducer. In this installation a recording unit complete with its amplifier is mounted on top of the cabinet as a single unit.

**Unique home-constructed sound reproducer that provides a non-directional sound distribution.**

WHEN we trace developments of sound reproducers, we fail to find any evidence where old and proven acoustic theories have been given much consideration; instead, many more complicated new theories and applications have been developed by independent research. There are certain fundamentals which govern good acoustical effects. In "Sensations of Tone" by Helmholtz, fundamental formulas covering acoustic principles can indeed be applied to our present-day loudspeaker designs with greater success than all the tried experimental shapes and designs that

have appeared on the market in the past 25 years.

Helmholtz has suggested that echoes and reverberations of musical sounds are the most important agents to quality, as is the importance of the false to the true vocal cords in voice. Helmholtz states that echoes and reverberations should not be absorbed but that we should learn to understand the handling of these factors rather than to destroy them. It can hardly be denied that in the acoustical arts, major attention has been given to the elimination by absorption of all these undesired echoes and reverbera-

tions, while architects and acoustical designers have formulated many fantastic shapes in order to produce good acoustical results in theaters, in large enclosures, or for outdoor application. It is a known fact that our most nearly perfect acoustic conditions are still to be found in some of our older buildings and none of the new architectural designs have come anywhere near producing as good results as we find in old brick structures.

In steel and concrete structures one should not look for good acoustics, regardless of the plasters that may be used on the inner walls. It is not that the concrete mass is detrimental, but the steel girders which form the skeleton of the structure are the deciding factor which tend toward poor acoustics in our modern buildings and churches. Compare the sound effects and distribution from many famous carillons in European countries; they can be heard for miles away. The same is true with relatively small bells in little villages, where the churches are often of brick or wood structure. The chief reason for such good effects is that the bells are not suspended from or anchored to steel girders but are more often suspended from heavy oak plank. As a matter of illustration, one needs only to observe the carillons from the Riverside Church in New York or the Mellon Church in Pittsburgh. They are among our latest and no doubt most costly belfry towers in the country, yet one has difficulty in hearing the carillons with reasonable fidelity a block away. The reason for this poor acoustical result has little to do with the openings in the belfry, or its shape, or the height from which they are suspended; it rests chiefly upon the fact that more than 75% of the total output is carried through the steel girders and grounded directly into the foundation of the church proper. As evidence, those who are familiar with the famous carillons in various European countries can best bear witness to the great difference represented in the beauty of the sounds coming from our famous cathedrals and the carillons in Mechlin, Ghent, Antwerp, Bruges, and Namur, which far excel results obtained in any of our modern architectural church structures employing carillons.

When sound motion pictures were first introduced into our theaters, many new forms and shapes of amplifying horns were developed in an at-



# SOUND REPRODUCER

tempt to achieve better and more natural hearing results in the many different sizes and types of architectural enclosures, but somehow the problem has never been solved to entire satisfaction. As a matter of fact, it was given up as hopeless more than 12 years ago, when it was decided that we should build theaters to accommodate the loudspeakers which were satisfactory in laboratory tests but were total failures when they were to operate under natural conditions. Many theaters have since been built to suit the sound equipment. One of the largest theaters to be built on Broadway, which received much advance publicity in that it promised to become the last word in perfection in the acoustical arts, turned out to be the biggest flop in sound motion picture theaters. In the *Film Daily Year Book* of 1931 a page was published titled "Remedies for poor acoustics in theaters," but we have still not developed an amplifying system which can become standardized for all forms of theaters. The truth of the matter is, we are still designing theaters to suit the sound system, and when the theater has been completed we often must redesign our sound system to suit the new theater. What finally is arrived at is a fair compromise and acceptable system worked out for each individual theater. This procedure is rather costly and could be avoided by a return to well-known acoustic principles which have proved to be excellent wherever employed.

The foregoing history has been cited merely to convince those interested in the acoustical arts that the selected building material and its mass is of greater importance than the shape within the theater as long as we do not totally disobey certain physical laws of shapes, as was the case in the formula embodied in the ceiling of Radio City Music Hall, the chief objection to which is that, instead of introducing an expansion factor, the ceiling introduced sharp reflective surfaces which resulted in many echoes when it was first tried out. This was expensive to overcome, perhaps the worst acoustical condition ever encountered in any theater before it was tolerably corrected with sound-absorption materials throughout; and then an abnormal increase of loudspeaker units became necessary to overcome the deadening effects on sound. The mistakes made in such outstanding structures are inexcusable if we fol-

low through with the mass of knowledge actually available in the science of acoustics.

The present illustrated directional and non-directional resonator and sound distributor challenges anything heretofore introduced toward perfection of good acoustics within large enclosures as well as for out-of-doors sound amplification. Theoretically and in practice it represents well-known acoustical principles and disobeys none of the acoustical laws. The relationship of air column, mass, and quality of material, as well as form, has been fully considered, as illustrated in the photographs, from which all structural details can be observed. The dimension constitutes a 24" cubicle air column, and the weight mass of this small chamber without any hardware or loudspeaker units installed is exactly 90 pounds. In comparison with any other empty reproducing chamber of similar size, this weight mass will be found three to four times heavier.

Five loudspeaker units of various dimensions can be installed within the 24" cubicle space and a four-sectional dividing section slides into the grooved segments, thereby separating the back of each unit from the next. The resonating box contains no other electrical equipment. The entire unit is preferably suspended from a ceiling height to a level most suitable and in proportion to the total ceiling height; or, when employed in connection with motion pictures, it is placed either directly above the screen, or one unit on each side of the screen—depending on the size of the theater proper.

The same unit can also be employed as a console cabinet, upon which may rest a radio and public-address amplifying system. In this way it forms a complete professional sound-recording unit of highest quality.

A six-way switch is built into the amplifier section, through which each independent unit can be controlled separately, or all five jointly. In substance, it may well be defined as a five-dimensional sound system, since each loudspeaker unit is sharply directional; yet, when all five units are operating, it introduces no directional characteristics whatsoever. This is particularly true when it has been suspended from the ceiling. One becomes aware of a totally new sound effect—that of quantum or mass sound, which theoretically would be the same as the fifth dimension. Helmholtz gave much

(Continued on page 98)

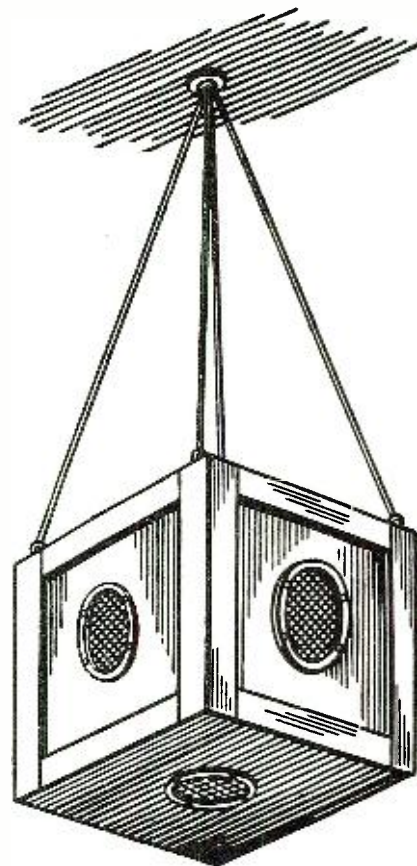

Although this unit may be used in the home, its tonal quality could not be fully appreciated unless it were mounted from the ceiling. In this position all speakers are effectively used.



Sectional view of 24-inch cubical shaped reproducer. The completed assembly excluding hardware and speakers weighs approximately ninety pounds. Five loudspeakers may be installed in the unit.

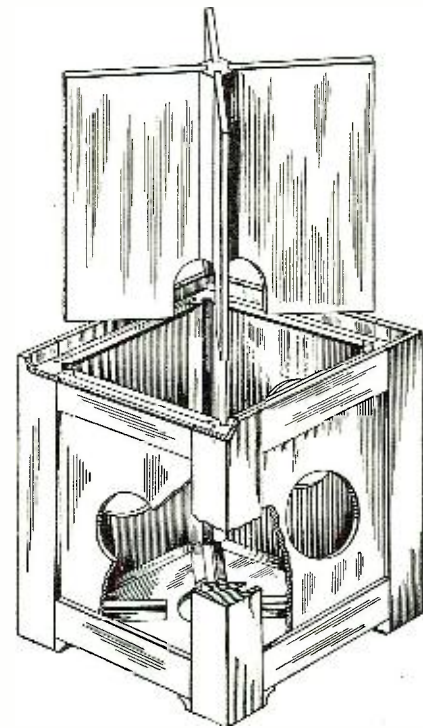



# Unusual TRANSMITTER for 28-54mc.

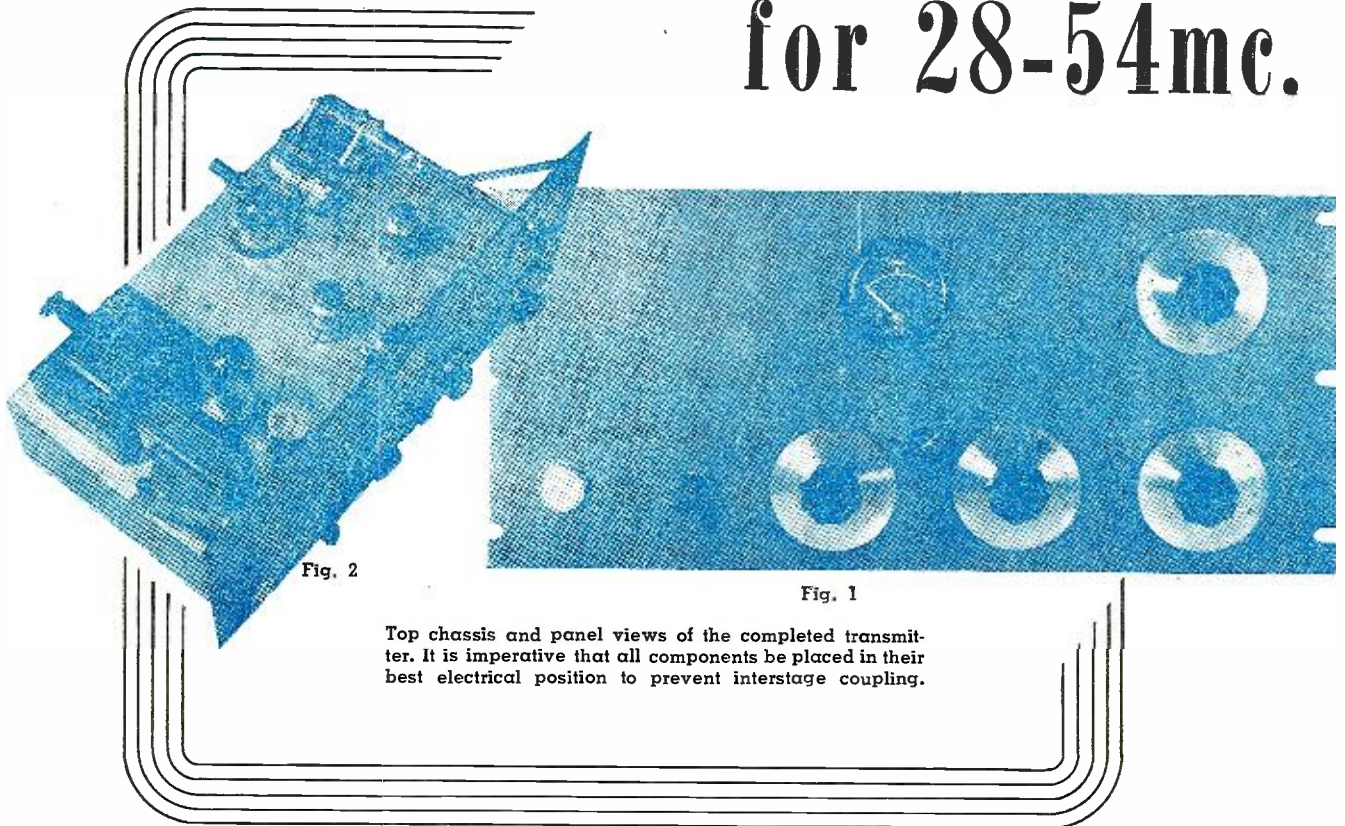

Fig. 2

Fig. 1

Top chassis and panel views of the completed transmitter. It is imperative that all components be placed in their best electrical position to prevent interstage coupling.

**By RUFUS P. TURNER, W1AY**

Consulting Eng., Radio News

## **Constructional details of a thirty-watt transmitter for operation on the 28-54 megacycle amateur bands.**

IN designing the subject 30-watt transmitter for the postwar 28-29.7- and 50-54-mc. bands, it was decided to employ rack panel construction, a minimum of controls, continuous tuning *between* and through-out the two bands wherever possible, crystal switching, and a self-contained power supply. Furthermore, it was decided to place each component in the best electrical position and "let the front panel sort of grow up like Topsy."

In our desire for simplicity we outlawed from the start neutralization and the long string of doublers found in so many crystal-controlled "5-meter" transmitters. Our demands thus dictated use of a dependable 30-watt u.h.f. type beam tetrode as the final amplifier. Low excitation requirements, low plate and screen voltages, u.h.f. efficiency, low cost, and small

physical size recommended the type 815 dual tetrode.

While the 815 normally requires only two-tenths of a watt grid driving power for 30 watts output, considerably more than this must be supplied by the last exciter stage in order to overcome grid circuit losses at 28 and 54 mc. To our discouragement we found that ultra-modern types like the 6AK5 simply would not supply

**EDITOR'S NOTE:** *At the present time the 28-29.7 and 56-60 mc. bands are assigned to amateur operation. By employing the eighth harmonic of the crystal used for the 28-29.7 mc. band, this transmitter will cover the 56 to 60 mc. region. The 50-54 mc. band, for which this transmitter was also designed, has not yet been opened to amateur use. It is anticipated that as soon as present services can be relocated, this band will be opened to the amateurs.*

sufficient u.h.f. driving power when used as doublers and quadruplers. So we fell back on less spectacular, but neither ancient nor old, exciter tubes.

The exciter portion of the transmitter consists of two 7C5 stages—a crystal oscillator-doubler and a doubler-quadrupler. By employing 200- $\mu$ fd. variable tank capacitors in each stage, continuous tuning is made possible without changing coils. The tank of the first stage covers the range 6000 to 15,000 kc. and may be tuned to the fundamental or second harmonic of crystals between 6000 and 7500 kc. The tank of the second stage covers the range 27,000 to 60,000 kc. and accordingly may be tuned to double or quadruple the *output* frequency of the crystal stage. Continuous-coverage exciters of this type do not give the same efficiency at both ends of their tuning ranges. But the characteristic drop in output at one end, particularly evident when quadrupling, can be tolerated since, with the 7C5 tubes, more than enough driving power is available for the 815.

The same continuous tuning feature is utilized in the push-pull grid input section of the 815 stage. Here a different size tuning capacitor is employed, but the coil-capacitor combination tunes from 27 to 60 mc. Continuous tuning is not employed in the 815 plate circuit for the reason that it



does not permit the best  $C$  and  $Q$  values for radiophone operation to be secured at all band settings. The 815 plate coil thus is the only plug-in inductor in the entire transmitter. This slight inconvenience may be tolerated, however, in the interest of modulated plate circuit efficiency.

50-54-mc. operation is obtained from crystals having fundamentals between 6250 and 6750 kc. For this operation the tank of the crystal stage is tuned to the 2nd harmonic of the crystal frequency (low-capacitance setting of the tuning capacitor). The first exciter stage, thus acting as an oscillator-doubler, delivers 12,500-13,500-kc. output. The tank of the second exciter stage is tuned to the 8th harmonic of the crystal frequency (low-capacitance setting of the second tuning capacitor) so that this stage, operating as a quadrupler, delivers 50-54-mc. output. The 815 grid tank is tuned to the same frequency as that of the second exciter stage (low-capacitance setting of the 815 grid tank capacitor) and the "5-meter" coil is plugged into the 815 plate circuit. 6250-6750-kc. crystals now are available at regular ham prices.

28-29.7-mc. operation is obtained from crystals having fundamentals between 7000 and 7425 kc. For this operation the tank of the crystal stage is tuned to the crystal fundamental (high-capacitance setting of the tuning capacitor). The first exciter stage, thus acting as a straight crystal oscillator, delivers 7000-7425-kc. output. The tank of the second exciter stage is tuned to the 4th harmonic of the crystal frequency (high-capacitance setting of the tuning capacitor) so that this stage, acting as a quadrupler, delivers 28-29.7-mc. output. The 815 grid tank is tuned to the same frequency as that of the second exciter stage (high-capacitance setting of the grid tank capacitor) and the "10-meter" coil is plugged into the 815 plate circuit.

A detailed description of the transmitter stages follows:

### Exciter

The complete circuit diagram of the transmitter appears in Fig. 6. We do not take full credit for the exciter section, having "borrowed" it from Heintz & Kaufman. To the original H. & K. design, however, we added the continuous-coverage tank circuits, crystal switching, "voltage-drop" metering circuit, and link-coupled output. After testing a number of likely appearing small u.h.f. tubes, the 7C5 locktals mounted in polystyrene sockets were found the most satisfactory for high doubler and quadrupler output in the 50-54-mc. region.

The first 7C5 stage is a type of grid-plate oscillator circuit with a cathode tank consisting of a  $2\frac{1}{2}$  millihenry pi-wound r.f. choke,  $RFC_1$ , shunted by a .00025- $\mu$ fd. mica capacitor,  $C_2$ . A simple crystal switching circuit is employed and has been found entirely satisfactory. The crystal stage plate

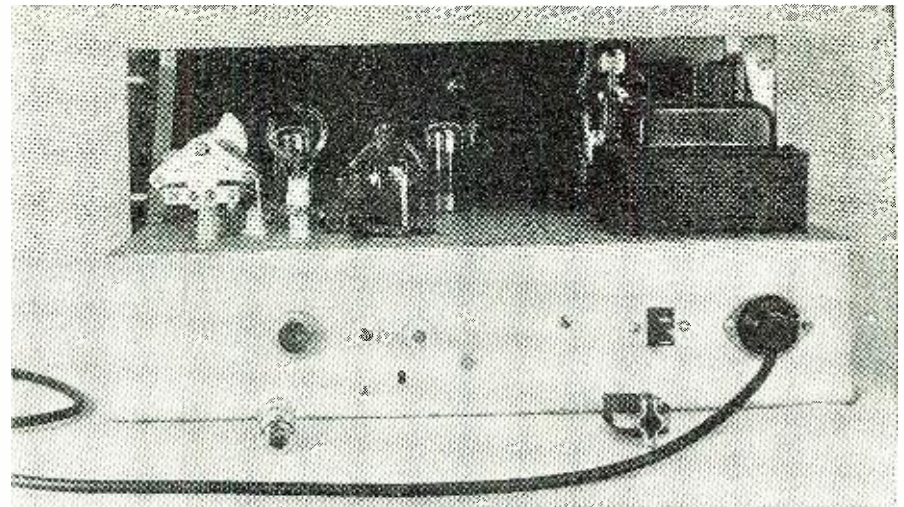

Fig. 3. Rear chassis view of completed instrument shows neatness of final assembly.

tank consists of a 200- $\mu$ fd. midget variable capacitor,  $C_3$ , and coil,  $L_1$ . The latter is 11 turns of No. 22 enameled wire wound on a 1"-diameter low-loss bakelite form, the turns being spaced apart a distance equal to the diameter of the wire.

The interstage coupling capacitor,  $C_6$ , is a miniature bakelite-molded .00005- $\mu$ fd. mica component. Our tests indicated no appreciable advantage in the use of ceramic or mica-button-type units in this position.

The second exciter stage has both

Fig. 4. Mechanical layout showing proper placement of various component parts.

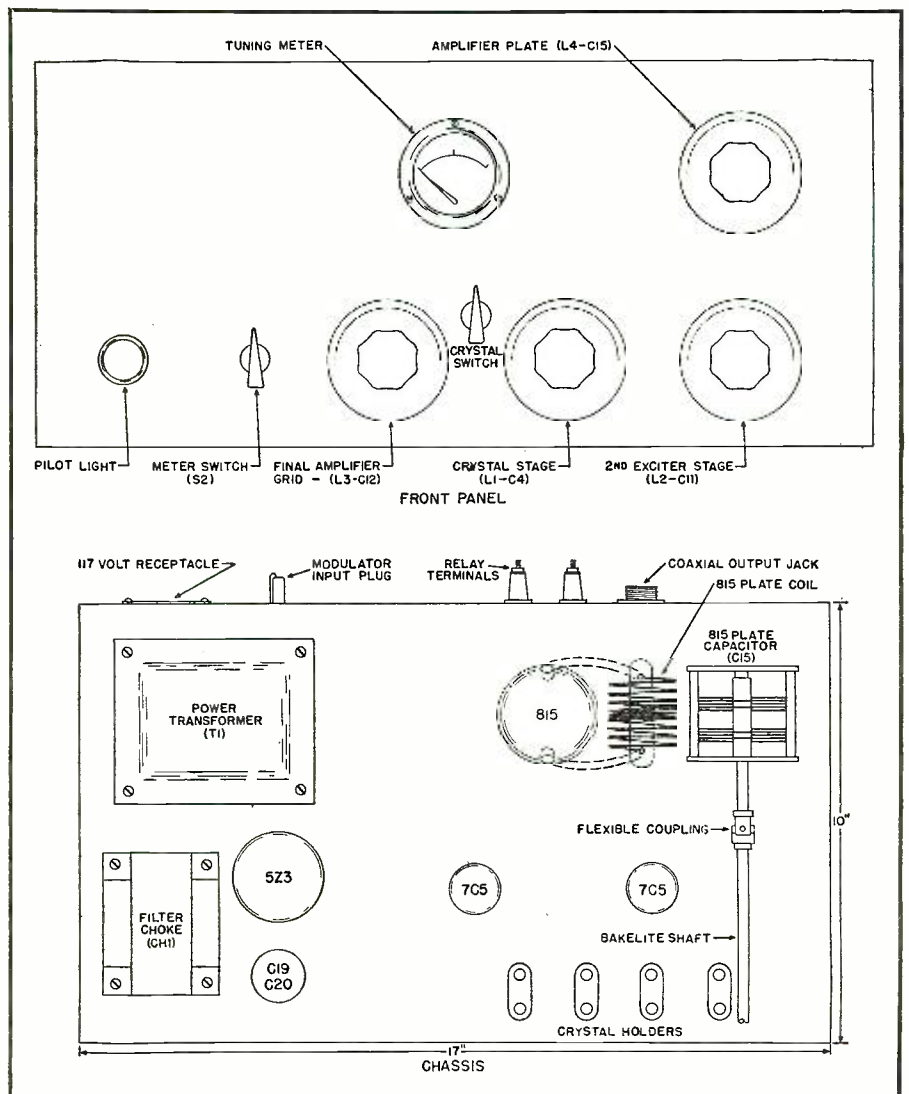



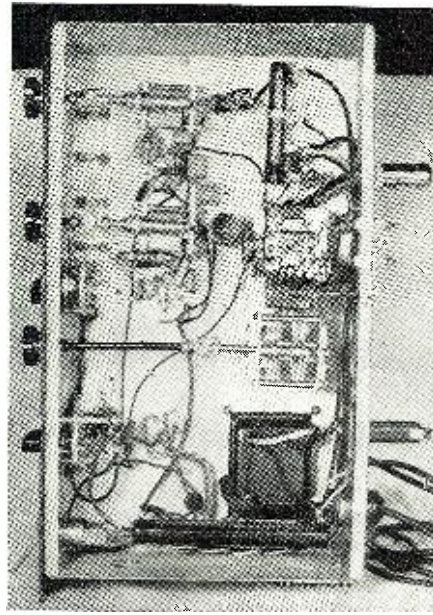
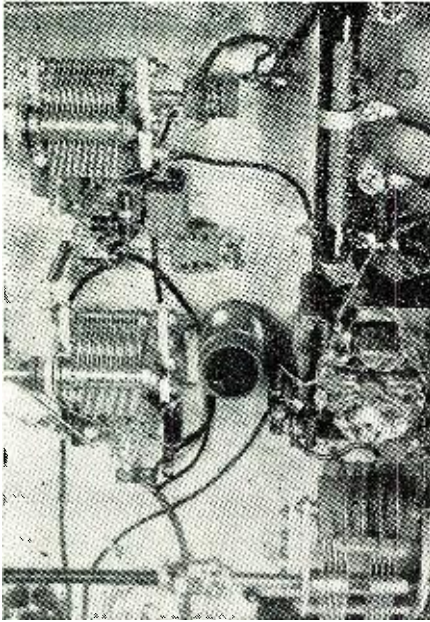

Fig. 5. Left: Close-up under-chassis view of the doubler-quadrupler (top) and oscillator-doubler stages. Right: Complete under-chassis view. Along the back edge of chassis (from top to bottom) can be seen the coaxial output, relay terminals, modulation input jack, and power-line receptacle. The recessed 815 socket can be seen just below the relay terminals. Power supply is at bottom right.

both input and output ends. The link-coupled input circuit was found especially helpful in achieving isolation and removing the necessity for neutralization. The link-coupled output makes it convenient to work the transmitter into various types of antenna couplers or directly into low-impedance, low-loss coaxial antenna feeders.

The grid tank consists of a dual 100- $\mu$ fd. tuning capacitor,  $C_{12}$ , and coil  $L_3$ . The latter is 4 turns of No. 14 enameled wire airwound 1½" in diameter and spaced ¼" between turns. The tap is at the end of the 2nd turn. The link winding is 4 turns of hookup wire closewound on a 1"-diameter bakelite form mounted inside  $L_3$  so that the link winding and the 2nd turn of  $L_3$  are exactly opposite.  $L_3$  is supported directly by soldering its ends to the  $C_{12}$  stator lugs.

The plate tank consists of a dual 50- $\mu$ fd. tuning capacitor,  $C_{15}$ , and coil  $L_4$ . The latter is a plug-in unit having a center-link winding. The coils employed in the writer's transmitter are National AR16-10C (for 28-29.7-mc. operation) and AR16-5C (for 50-54-mc. operation). The 28-mc. coil is seen in position in the photographs, Figs. 1 and 3. The concentric line running from the  $L_1$  link winding to output jack,  $J$ , is a short length of low-loss u.h.f. type coaxial conductor.

The 50-ohm, ½-watt carbon suppressor resistors,  $R_6$ ,  $R_{10}$ , and  $R_{11}$ , are essential to stable, oscillation-free operation of the 815. All three of these resistors must be employed.

When a single milliammeter is employed as the tuning indicator in a  
(Continued on page 120)

cathode and grid-resistor bias. The grid resistor is ¼ megohm,  $R_2$ , and the cathode resistor 500 ohms,  $R_4$ . The plate tank in this stage consists of a 200- $\mu$ fd. midget variable capacitor,  $C_{11}$ , and coil,  $L_2$ . The latter is 2 turns of No. 22 enameled wire wound on a ½"-diameter low-loss bakelite form and spaced ¼" between turns. The link winding is 2 turns of hookup wire wound close to the "B+" end of

$L_2$ . The twisted pair line connecting the link windings of  $L_2$  and  $L_3$  likewise is made of hookup wire.

The central locating plug of each 7C5 tube is grounded to the chassis right at the tube socket by means of the socket terminal provided for this purpose.

### Final Amplifier

The 815 amplifier is link-coupled at

Fig. 6. Complete schematic diagram of the four-tube 28-54 mc. cycle transmitter. The audio power from an externally connected modulator unit is applied in series with the d.c. power supply and plate-screen circuit of the 815 tube.

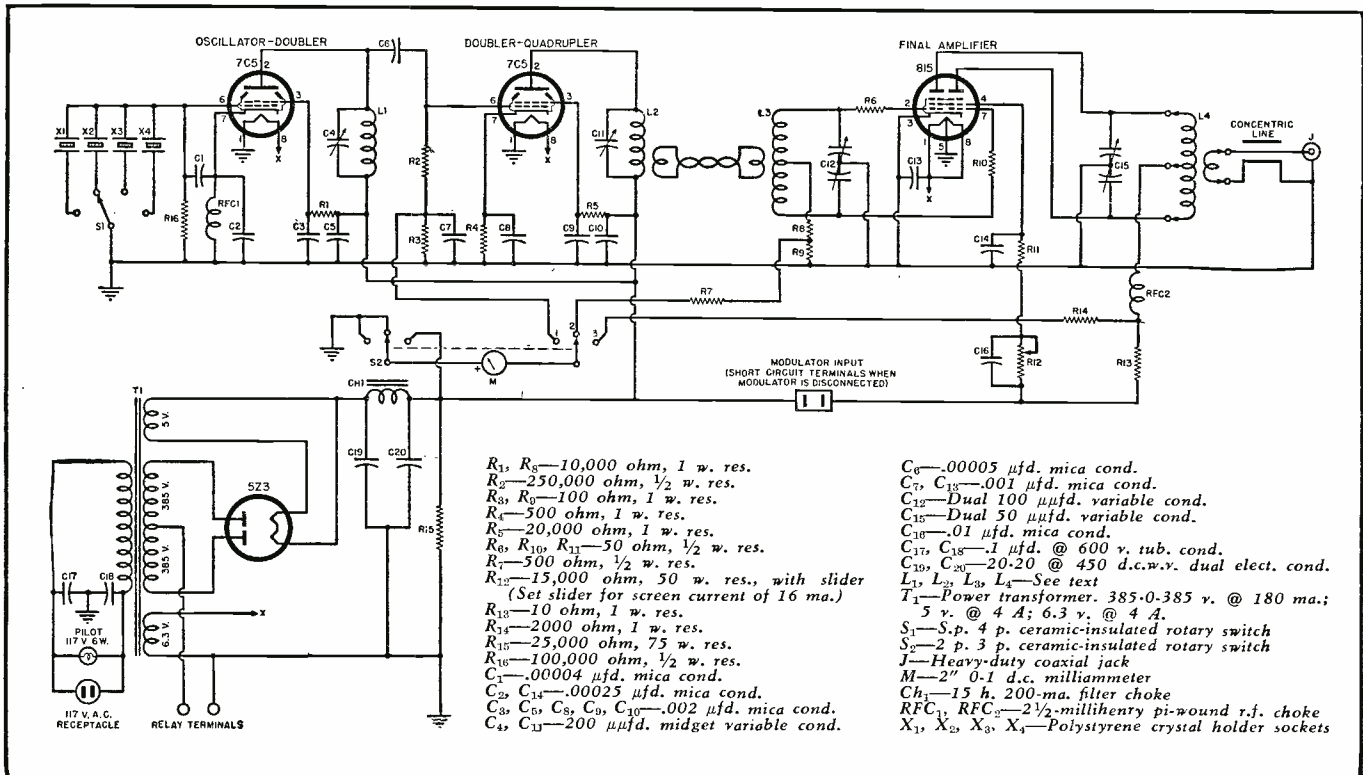



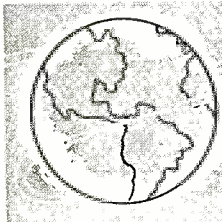

# International

# SHORT-WAVE

Compiled by **KENNETH R. BOORD**

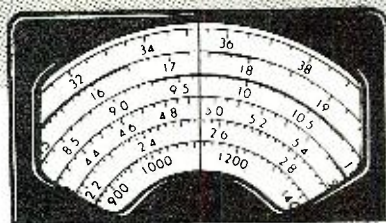

THEY tell us that the proof of the pudding is in the eating. So it is with verifications to the DXer. This was aptly put by Robert E. Hatcher, Virginia, writing in a recent issue of *Universalite* (bulletin of the Universal Radio DX Club): "DX season is here again and this year things will be brighter than in years gone by, as there will be more radio stations on the air and the arrival of those verification cards will begin to find their way to your address. The good old days are on the way, so draw up the chair, dust off the receiver, and hang out the antenna, 'cause there's DX calling you. Logging a station is a wonderful feeling, but the best feeling comes when the postman hands you a verification from some far-off station that you have longed to verify. Yes, the verification is the 'pay-off'."

How do you get a verification? The following suggestions are offered by various veteran monitors:

1. Be certain you *actually* have the station. Listen for *positive* identification.
2. Make as complete notes as possible, listing what *actually* went on during at least 15 minutes of a particular transmission period, preferably longer.

a. Set down local time in your area

and, in parenthesis, if you know it, the local time at the point of transmission. By all means also list GMT, which is used by most transmitters on their own records. (GMT is 5 hours *ahead* of EST.)

b. List what was *actually* heard, giving *exact* time of such items as identification, certain specific recordings, if used, names of musical programs or numbers, and the like.

c. List the frequency and wavelength announced, if given. If the station came in at a different frequency than announced, mention that radiation came in on *approximately* \_\_\_\_\_ *megacycles* on your receiver.

d. Advise them the signal strength. If you have a communications receiver, list the carrier level as R-7, S-5, or the like; if an ordinary home receiver is used, mention reception as *weak*, *strong*, *clear*, *fading*, *code interference jammed by another station*, *so-and-so*, giving that station's frequency and location, too, for check purposes.

e. List what kind of receiver was used, the kind of antenna employed, and state weather conditions at the time you monitored the station; also time of local sunset.

3. Make your report from what you have set down; be *brief*, but *concise* and *specific*. Ask for a verification

of such reception. If you can offer *constructive* criticism and suggestions that would be helpful, do so.

4. Send your report *first-class*, being certain that sufficient postage is affixed to your letter. According to the Post Office Department in Washington, service for the transmission of letters and post cards has been resumed to all European countries to which it was formerly suspended *except* Germany, Austria, and Albania. For changes in postal service to foreign countries consult your local post office.

(NOTE: Some stations will not verify from abroad unless you send along an international reply coupon, which you obtain for ten cents at your local post office; this is good for one unit of first-class postage in most foreign countries. According to the Post Office Department: "In the absence of information to the contrary, it is assumed that international reply coupons will be accepted by all countries to which mail service is in operation *except* Nicaragua, Italy, and Vatican City State." It is further stated that "due to conditions brought about by the war, this Department has been unable to maintain an adequate supply of international reply coupons, and for that reason the stock at certain post offices may become depleted. If one post office is unable to furnish these coupons upon demand, inquiry should be made at other offices in the locality.")

Some DXers prefer to send reports *first-class airmail*; information as to foreign airmail service also can be obtained at your local post office.

5. Summarizing, make your letter *brief*, but comment on the quality of reception and give suggestions that might be helpful to the station to which you are reporting. If you know the language of the transmitting country, write in that language; otherwise write in English. And be certain you have the correct address on the envelope, as well as your own correct return address on both the envelope and the report. *Then wait and hope*—give the station ample time to reply—(two to six months in most instances) before you write a second time. If you don't get a reply the first time and have not sent an international reply coupon, it is suggested you send an IRC with your second re-

(Continued on page 82)

Listening Post of Gilbert L. Harris, North Adams, Mass. During the war, Harris picked up an Arab station which few people were able to receive; it was being used by the Germans as a "blind" to agitate racial prejudice. He also picked up the communications from Admiral Byrd when he was at the South Pole. Gil's main receiver is an NC-200 used with an RME-DB-20 and LF-90. The second receiver is a Hallicrafter Sky Traveler Model S-29. Atop the RME-DB-20 is a Motorola FM tuner that feeds into the NC-200 receiver. Atop the FM tuner is a barometer. Aerials include one vertical 12-foot antenna on roof for FM; one 60-foot doublet that runs N-S; also one single wire antenna of about 35 feet that runs E-W. He has also a 14-foot antenna inside his radio room, to be used only if bad storms break down the outside antenna system.

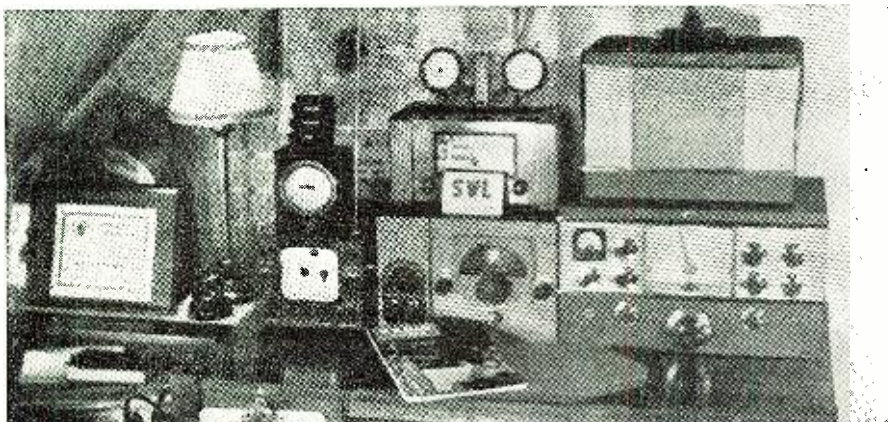



# RESISTANCE MEASUREMENTS

By Shepherd Litt, W2LCC  
Superior Instruments Co.

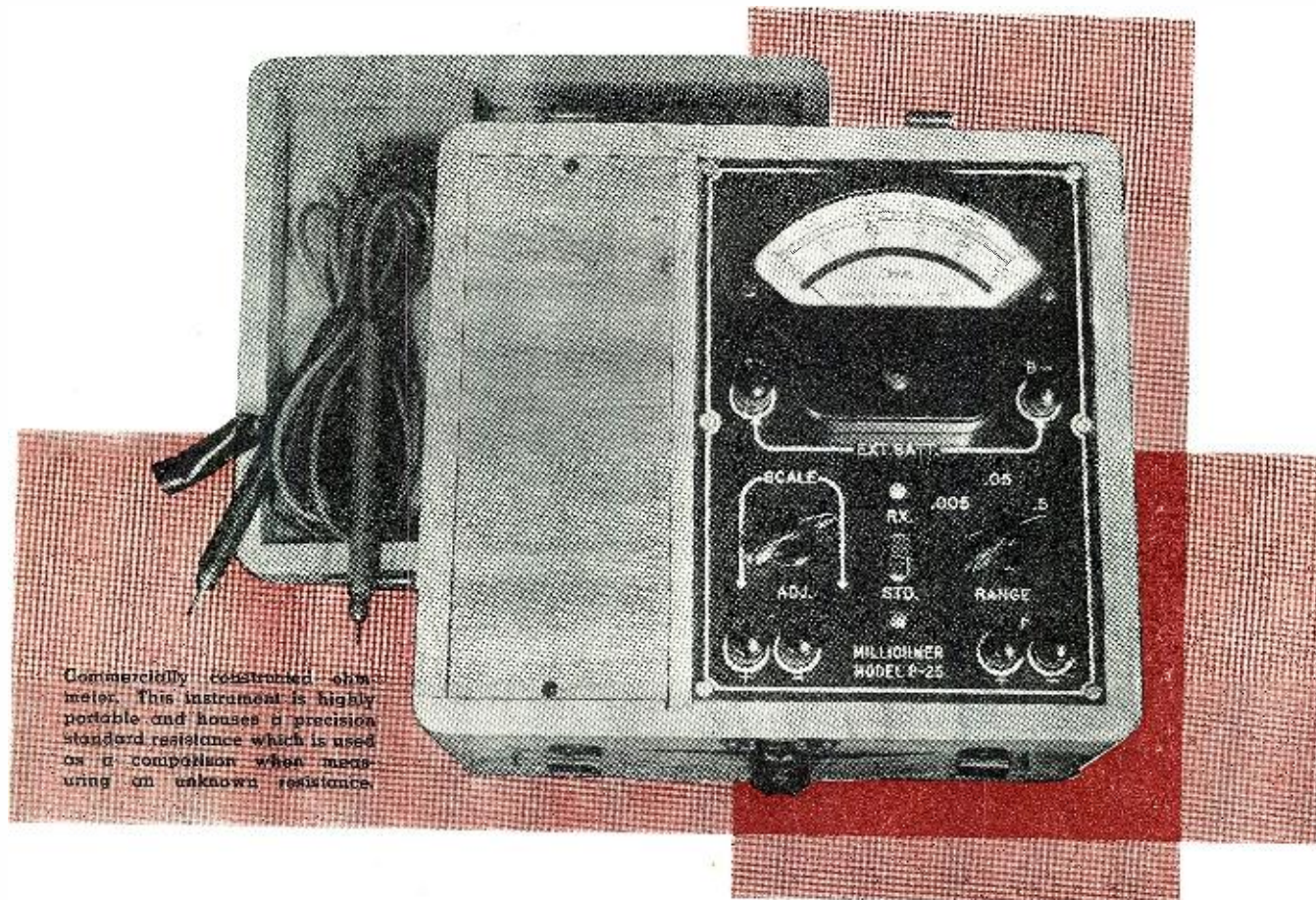

Commercially constructed ohmmeter. This instrument is highly portable and houses a precision standard resistance which is used as a comparison when measuring an unknown resistance.

***A review of the various methods used in the measurement of resistance, from the simplest form to the more highly accurate laboratory methods. Examples are presented whenever their use is justified and formulas worked out so that anyone, with a small working knowledge of mathematics, can make accurate measurements.***

**A**CCURATE resistance measurements are an essential part of laboratory procedure. For some types of work, an accuracy of  $\pm 2\%$  is adequate, while under other circumstances, much higher accuracy is necessary. This article discusses several methods of resistance measurement including the simple ohmmeter, the wheatstone bridge, and the Kelvin bridge.

Among the simplest methods that can be employed in the measurement of resistance is the so-called ammeter method. This method, illustrated in Fig. 1A, employs a source of potential, an ammeter or milliammeter, and the unknown resistance.

Ohm's law states that  $R = E/I$ . Resistance is equal to the voltage im-

pressed across a circuit divided by the current flowing through the circuit. If we employ a 1.5-volt cell as a source of potential and impress this voltage across an ammeter and unknown resistance in series, and the ammeter reads .2 ampere, the *circuit* resistance is 7.5 ohms. Note that 7.5 ohms is not the resistance of the *unknown resistance*, but is the resistance of the *entire circuit* (unknown resistance, ammeter, connecting wires and internal resistance of the cell).

To determine the resistance of the resistor, it is necessary to deduct the ohmage of the ammeter, wires, and internal resistance of the cell from 7.5 ohm total. In order to obtain high accuracy in this method, several points must be borne in mind.

1. Use a large cell having low internal resistance (a storage battery is ideal).
2. Use large-diameter connecting wires having low resistance.
3. Use an ammeter having a very low resistance.
4. Know the resistance of the ammeter.
5. Be sure that the ammeter is accurate.

For values of resistance above 10 times the resistance of the ammeter, the ammeter resistance, the connecting wires, and the internal resistance of the cell may be disregarded. The accuracy of the ammeter method can be further increased by employing a standard resistor and basing the calculations on this standard (Fig. 1B).

**RADIO NEWS**



Assuming that the standard resistance is 10 ohms, then, with the switch in position No. 1 the ammeter reads 1 ampere. With the switch in position No. 2 the ammeter reads .25 ampere. Since the amount of current passing through a resistance is inversely proportional to its resistance, then

$x : 10 = 4 : 1$ ; or the resistance of the unknown is 4 times the resistance of the standard, or 40 ohms.

**Voltmeter Method**

Should no ammeter be available, a voltmeter may be used (Fig. 1C). If  $E_1$  is the impressed voltage read by the voltmeter, and  $E_2$  the voltage read when the unknown resistance is placed in series with the voltmeter, then

$$\frac{E_1 - E_2}{E_2} \times \text{resistance of meter} = X_R$$

As an example, if the meter (having a resistance of 10,000 ohms) in position 1 reads 6 volts (the battery voltage) and in position 2 reads 4 volts, then

$$X_R = \frac{6 - 4}{4} \times 10,000 = \frac{2}{4} \times 10,000,$$

or 5,000 ohms.

This is a very important formula and most commercial ohmmeters use this principle.

The voltmeter method is simple and can be used to read higher resistances than the ammeter method. The main disadvantage of the voltmeter method is that the meter must be capable of close reading and its resistance must be known.

The voltmeter method can also be used in conjunction with a standard resistance to improve its accuracy. It will be described later on under Laboratory Measurements, as it is capable of high precision.

**Ohmmeter Method**

The common ohmmeter is a variation of the voltmeter method. There are two types of ohmmeters, the series type (Fig. 2A) and the shunt type (Fig. 2B).

In the *series type*, a battery, a milliammeter, and a resistor are connected in series with the unknown resistor. As such, the resistor and the meter constitute a voltmeter which can be brought to full scale to correspond to the voltage of the battery. The value of the resistance required can be computed by Ohm's law.

If a 1-ma. meter and a 4.5-volt battery are used, the series resistor would then be 4500 ohms.

This can be made up by using a 3000-ohm resistor and a 1500- or 2000-ohm adjustable control. With the unknown resistance terminals shorted, the meter is made to read full scale by varying the adjustable control. The unknown resistor is then put in the circuit and the reading noted. If the unknown resistance were to be 4500 ohms, the total resistance in the circuit would

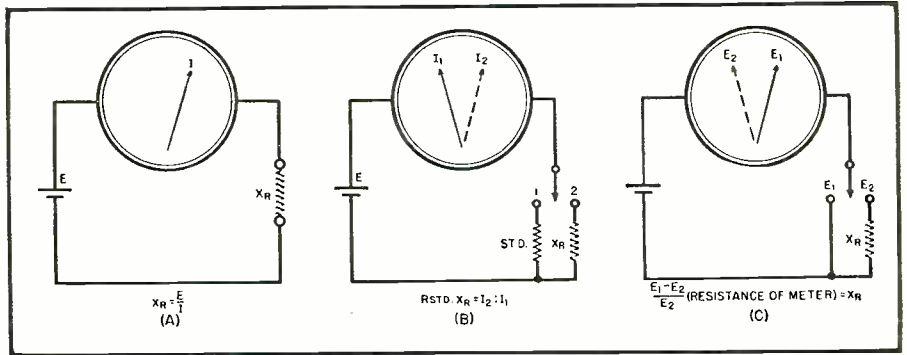

Fig. 1. (A) Diagram illustrates ammeter method of measuring resistance. (B) Similar to that of (A) with the exception that a standard resistance is used as a comparison. (C) Diagram illustrates voltmeter method of resistance measurement.

be 9000 ohms and the 1-ma. meter would become a 9-volt voltmeter. Since a 4.5-volt battery is being used as a source of potential, the meter will read half scale. A resistance lower than 4500 will cause the meter to read more than half scale, while a resistance greater than 4500 ohms will cause the meter to read less than half scale. Zero resistance, therefore, will correspond to full scale and would appear to the right of the meter scale. If a meter having a regular linear scale is used, the scale can be changed to an ohmmeter scale by employing the following formula:

$$\frac{R_2}{R_1 + R_2} \times \text{divisions on meter}$$

when  $R_1$  = meter resistance (as a voltmeter),  $R_2$  = unknown resistance.

Using the above-mentioned meter and battery as an example, and if the meter is a 1-ma. type with 4500 ohms internal resistance and with 50 divisions on the scale, and the battery is 4.5 volts, a 4500-ohm resistor would read:

$$\frac{4500}{4500 + 4500} \times 50 = \frac{4500}{9000} \times 50 = .5 \times 50,$$

or 25 divisions on the 50-division scale. A 10,000-ohm resistor would read 16 divisions on the same scale, and a 500-ohm resistor would, in like manner, read 45 divisions.

The above method is the method employed by the writer in calculating the resistance scales for one manufacturer in the instrument field.

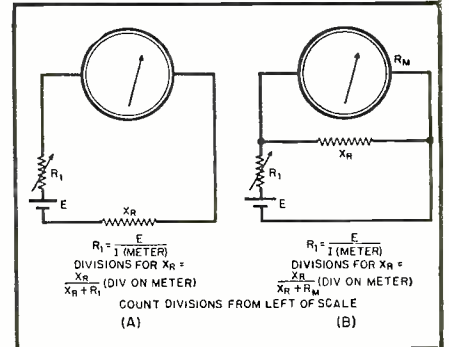
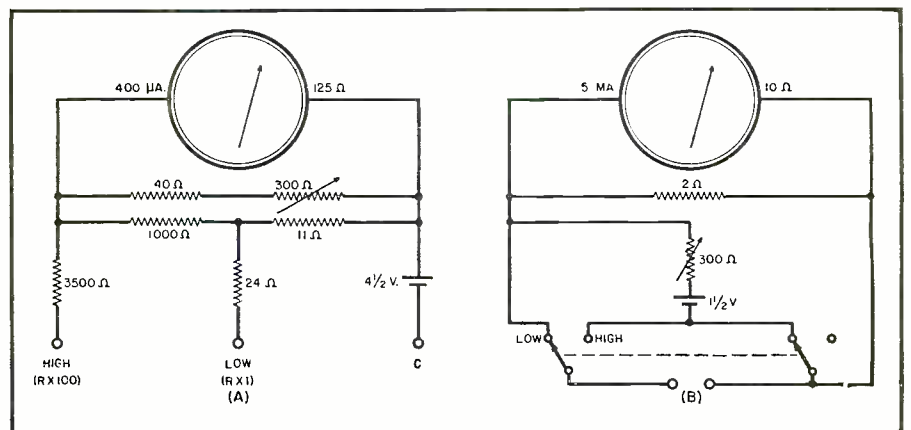

Fig. 2. Commonly used ohmmeter. There are two versions of this particular type: (A) Series type, and (B) Shunt type.

In order to reduce the range of the meter, a shunt can be employed. By using a shunt to change the aforementioned 1-ma. meter to 10 ma. and reducing the series resistance to 450 ohms, a reduction ratio of 10 is brought and the center of the resistance scale then becomes 450 ohms. To increase the range of the ohmmeter, either a 45-volt battery and 45,000-ohm resistor or can be employed with the 1-ma. meter, or the meter sensitivity can be increased 10 times to 100 microamperes.

In the above ohmmeter, the resistor in series with the meter acts as a "zero adjuster control" to compensate for battery voltage changes. In multirange instruments, this "zero adjuster control" must be made with a special taper so that it can be employed suc-

Fig. 3. (A) Ohmmeter employing a zero adjusting control that is placed in shunt with the meter. (B) Commercial-type ohmmeter based on both the series and shunt circuits.





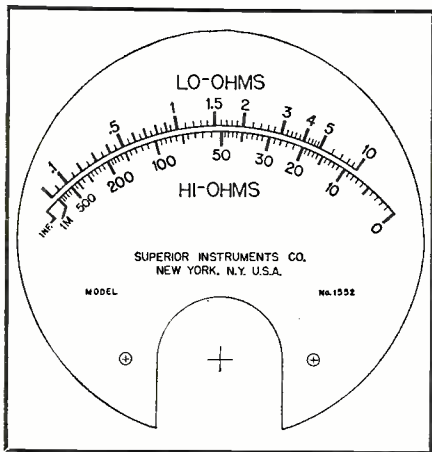

Fig. 4. Scale divisions of a commercially built ohmmeter. Superior Instruments Company's model 1552.

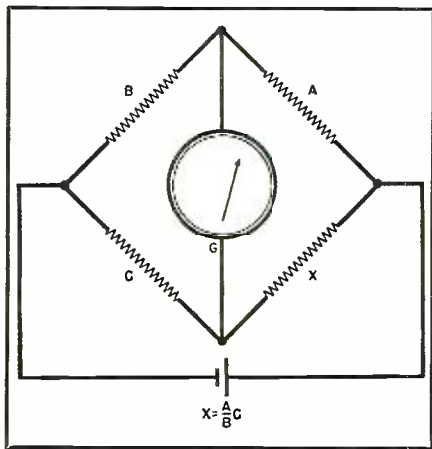

Fig. 5. Wheatstone bridge.

cessfully to vary the meter on all ranges. It is often better to place the control across the meter and use a fixed series resistance. This is advantageous because the control has a much better adjustment in this position and the circuit can be proportional, so that no adjustment need be made when changing ranges. Fig. 3A shows such a circuit.

The low range of the instrument is 0-5000 ohms, with 35 ohms center scale; and the high range is 0-500,000 ohms, with 3500 ohms center scale.

The series type of ohmmeter is the most common type of ohmmeter in use today, its accuracy being normally 2% of the linear arc; i.e., if the arc of the

Fig. 6. Kelvin bridge.

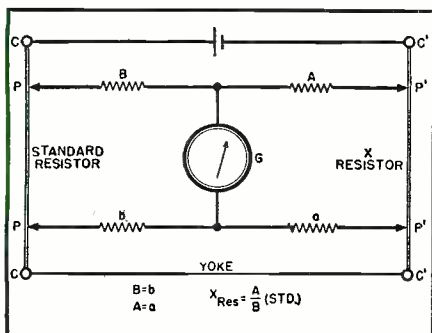

meter is 90°, then all readings are accurate to 1.8° at any part of the scale.

Although the series ohmmeter is often used for low resistance measurements, it has been deemed advisable to use another circuit in place of it. Referring back to the circuit of Fig. 3A, the low range consists of the 24- and 11-ohm resistors in series with the unknown and the 4.5-volt battery. If the unknown resistance is 10 ohms, a total of 45 ohms is in series with the battery. Neglecting the current used to actuate the meter, this means that a current of 100 ma. is being taken from the battery, and if used continually for low resistance testing, would exhaust the battery. To circumvent this, the shunt ohmmeter is used.

The *shunt* type (Figure 2B) is the series ohmmeter with the leads shorted and the resistance placed across the meter. The effect of the resistance in this position is to act as a shunt across the meter to reduce the scale reading. Since a short across the meter will cause the meter not to read at all, the zero point corresponds to the zero of a regular voltmeter, pointing to the left and the "infinity" mark to the right.

The formula for calculating the shunt ohmmeter is exactly opposite that for the series ohmmeter, and can be written:

$$\frac{R_1 + R_2}{R_2} \times \text{divisions of the meter scale.}$$

Because of this fact, the resistance of the meter appears in the center of the scale.

The shunt ohmmeter finds its chief use in measuring resistances less than 100 ohms. If the meter is to measure resistances less than 6 ohms, the length and resistance of the test-leads must be figured into the computation of the scale. A pair of commercial test-leads (36") has a resistance greater than .06 ohms. If the resistance were not taken into account when the scale of the meter was computed, an error of 1% would exist at the 6-ohm point. The error at .6 ohms would be 10%. If the resistance of the test-leads were added to the meter resistance, the error would be eliminated.

A typical commercial ohmmeter employing both *series* and *shunt* circuit is diagrammed in Fig. 3B. This is a commercial ohmmeter manufactured by Superior Instruments Company, their model 1552. The scale of this instrument is shown in Fig. 4. The series ohmmeter is used for the high range of 0-1000 ohms and the shunt ohmmeter used for the low range 0-10 ohms. Note that the end of calibration of the low resistance scale is not at the extreme left, but slightly before the end of the scale. The zero point corresponds to the .06 ohm test-leads used with this instrument. Some commercial instruments omit the "zero adjuster" control by employing a magnetic shunt across the meter. This has the effect of increasing or decreasing the sensitivity.

The above methods are commercial methods in use today and, unless extreme precautions are taken, cannot successfully be used to measure better than 2%. To achieve a higher degree of accuracy, laboratory methods must be used. Two general methods are employed in the laboratory: the potentiometer method and the bridge method.

In the *potentiometric method*, the voltage drop across the standard resistance is compared to the voltage drop across the unknown. It can best be described as the voltmeter method used with a standard resistance. (A potentiometer is an instrument measuring voltage below 1.6 volts, employing a null method. It is adjusted and calibrated by means of a standard cell and has an accuracy of better than .05%. Most laboratory potentiometers have an accuracy of .01% and .02%.)

In the method employed, current is sent through both the standard resistance, usually having an accuracy of .05% or better, and the unknown resistance. The voltage drop across the standard is read first, and then the drop across the unknown, by means of the potentiometer. If, for example, a standard resistance of 1 ohm is used and the voltage drop across it is found to be 1 volt, with the voltage drop across the unknown 1.016 volts, the unknown resistance is 1.016 ohms. This is true since the same current that passed through the two resistances makes their voltage drops proportionate to their resistances.

A commercial instrument utilizing this principle, the model P-25, manufactured by Superior Instruments Company, operates on the following principle: A current is sent through a precision standard resistance and the unknown. The voltage drop across the standard is adjusted until the meter reads full scale, by means of a control and a momentary "standardizing" switch. When the switch is released the drop across the unknown is read. Although the instrument really measures voltage drops, the scale is calibrated in ohms. The indicating instrument is a precision mirror-scale millivoltmeter, having 100 divisions. Range of the instrument 0-.005, 0-.05, 0-.5, since it was made primarily to measure low resistances such as solid rods of metals, switch contacts, etc. The lowest reading possible is .00005 ohms with the limit of error 1 division or 1% at any part of the scale. Readings can be estimated to 1/4 division. Although this instrument was made primarily to measure low resistances, it can be converted to read high resistances by a small change in wiring. It should be especially noted that the scale of this and similar instruments operating on the same principle are *linear*, as compared with the crowded scales of ordinary resistance meters.

The more common type of laboratory resistance meter is the *bridge*. There are two basic types of bridges: the wheatstone bridge, for measuring resistances above .1 ohm, and the Kel-

(Continued on page 133)





Broadcasting from an army plane high in the clouds, this field engineer is part of the vast crew which brought America "on the spot" reports during the war.

By **HENRY J. SEITZ**  
 Technical Operations Dept., CBS

# FROM STUDIO TO MASTER CONTROL

*The versatile technical skill, speed, and cooperation required of all broadcast engineers has made possible the development of present-day commercial broadcasting.*

THE broadcast engineer of today is the product of long years of self application and patience expended in the crude workshop, attic-hamshack, and basement laboratory of a decade or so ago. He is the result of unselfish devotion to a progressive science which will undoubtedly advance humankind far beyond any conception we may hold on the subject today.

Within the past quarter of a century we have seen the broadcasting industry grow from a relatively obscure position into the vast, complex organization it now represents. It is, therefore, only natural that the men who are most intimately associated with this industry, the broadcast engineers, grow in like manner, devel-

January, 1946

oping the skillful efficiency, decisiveness, and rapid co-ordination so characteristic of today's engineers.

Although this varies for certain sections of the country, not a large number of technical broadcast personnel possess an accredited college engineering degree. A greater majority have, at one time or another, pursued similar, though not equivalent, courses in specialized radio home study correspondence courses. In addition to the basic requisite, a radiotelephone first class ticket, many men have radiotelegraph licenses by virtue of their past experience.

Complementing a good theoretical background, most engineers have between five and ten years of practical work in kindred fields such as tele-

phone long-lines operation, radio servicing, and amplifier design, to mention a few. It is also interesting to note that over ninety per-cent of them were at one time quite active in radio amateur circles. Fully one-half of today's broadcast engineers continue to design, build, and service equipment as an avocation to their regular daily work.

Modern broadcasting demands of its practitioners not only a comprehensive electronic background but also a good practical operational ability in utilizing the various pieces of equipment from studio transcription turntable and microphone to transmitter and transmitting antenna. A broadcast engineer may be called upon one day to operate a fast, tricky record show while the very next day may find him at some remote point setting up microphones, amplifiers, and such equipment as is necessary for field operations. At still other times he may be assigned to operate the master control board or work at the station's transmitter.



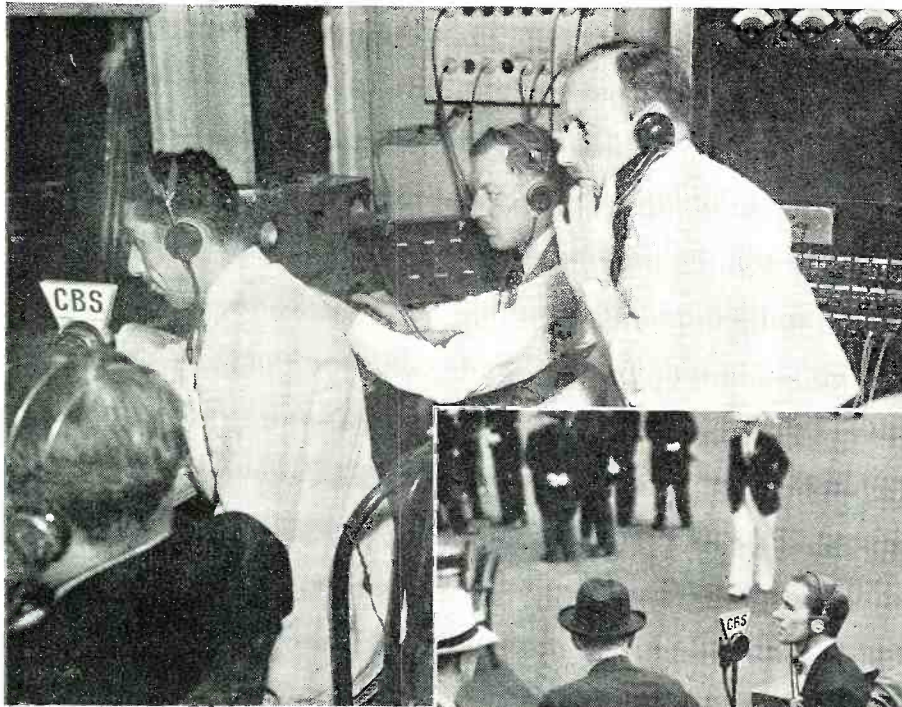

Equipment for a remote broadcast depends upon the program to be aired. Here the field engineers are seen using the "fixed location" equipment to bring the radio audience an important event.

Given less than an hour's notice, the field engineer can assemble, transport, and set up his equipment so that he is ready to go "on the air" with an eyewitness account of news in the making.



No technical limits can be placed on the varied duties an engineer may be called upon to perform. This fact becomes even more apparent during an emergency, which, by the way, always manages to arise at the most inopportune time. However, it is a rule of the larger companies to adhere to more or less a fixed schedule of technical operations, instead of a daily or weekly shifting of personnel. In this manner the various engineers are assigned to certain definite groups such as *studio, field, master control, maintenance, or transmitter*. Years of experience have proved that this procedure not only makes for ease and familiarity of assignments but also has the more pertinent benefit of reducing operating errors to a minimum.

Whether transcriptions or live talent is used, studio operations, with various programs, constitute the nucleus of broadcasting. This is the center of gravity around which all other departments revolve, each contributing their combined efforts to fulfill whatever requirements the public or commercial advertiser may demand. Studio operations embrace a

wide variety of programming. Basically, however, a radio show is dramatic in either style or music and it may even combine the characteristics of both, as most programs do.

Although the acoustical properties of the studio greatly affect the quality of speech or music, their natural reproduction depends on the type of microphone used and its placement with regard to the source of sound. Invariably it is the studio engineer who determines the type, number, and placement of these. It is, therefore, his duty to combine in a harmonious balance, with regard to intensity and quality, the various sounds picked up by the studio microphones.

A good musical balance between instruments comprising a modern

dance orchestra is at times a difficult thing to achieve, especially in view of the fact that most of today's band leaders were once musicians themselves and naturally tend to favor certain types of musical instruments.

In many instances this over-emphasis of a certain orchestral section over others is actually what is sought for and this must always be kept in mind by the engineer at the mixer (Fig. 3). It is an interesting study in contrasts that whereas a dance orchestra requires from two to four microphones for sectional pick-up, a symphonic group may use but one for complete coverage.

The wide popularity that certain dramatic shows enjoy depends a great deal on their liberal application of unusual sound and vocal effects. In this regard the engineer works in close accord with the sound effects man to produce anything from a voice in the spirit world to the shattering roar of a prehistoric monster.

At some portion of the program, the script may call for a reverberant vocal effect. As seen in Fig. 1, the equipment necessary to produce this is rather simple, consisting of a loudspeaker mounted at one end of a low, long hallway, at the other end of which a microphone is placed. A noticeable echo effect is obtained depending upon the distance between the two. However, the degree of echo is controlled by the engineer through

Fig. 1. Block diagram of a typical broadcast studio echo set-up.

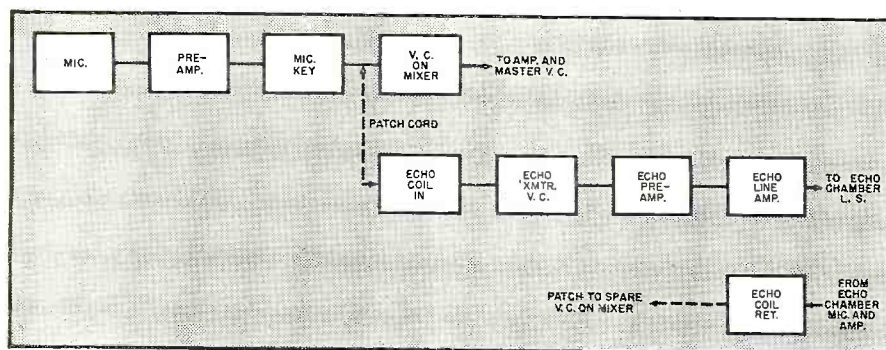



the use of attenuators located on both echo transmitting and receiving lines, the latter of which naturally terminates in the studio control booth. Where space is at a minimum, effects such as these may even be accomplished electronically by means of time delay circuits operating inside a small box-like affair.

Variable filter networks designed to cut off various frequencies within the audio range are also mounted within easy reach and their frequent use is a daily occurrence. Combinations of both filter and echo result in extraordinary effects, dear to the hearts of program directors.

Another quite important phase of broadcast operations, in so far as most of the smaller stations are concerned, is the work of the turntable operator. It is not at all unusual in his type of work to fade in and fade out portions of dissimilar recordings while closely following an announcer's cues. He must also change turntable speeds and switch in the correct amount of filter to accommodate the wide variety of transcriptions in use at the time. During these octopian-like motions a normal level must somehow be maintained on the line going to master control.

Most people when listening to recorded music, especially of the symphonic and operatic type, have the erroneous impression that an entire selection is contained on but one recording. In some instances this might be so, but in most cases the very ordinary type of album transcription is used. In playing these for broadcast purposes an engineer plays them in their true consecutive order using two

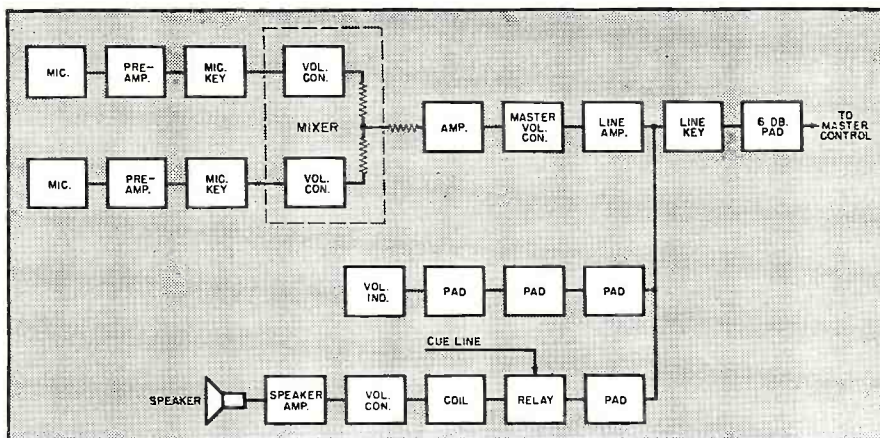

Block diagram of broadcast studio microphone sequence.

or three transcription turntables during the process. By switching from one to the other, the listener is given an impression of orderly symphonic sequence just as if he were attending the concert in person.

Exclusive of playhouse programs, *spot-broadcast*, *remotes*, *nemos* are all similar terms associated with the field department of technical operations and serve to signify any broadcasting done some distance away from the station's master control. These distances may vary from a few city blocks, for a local night club pick-up, to a few hundred or even a thousand miles or more. In the latter case, however, the network facilities and station affiliates of the larger companies are advantageously utilized.

In a non-technical sense hundreds of radio listeners are all too familiar with field broadcasts of important po-

litical and military personalities, movie stars and business executives, made from country air fields, ocean going liners, and modern banquet halls. Yet, very few of them realize the enormous amount of labor, speed, and co-operation which these programs entail. Field engineers will sometimes be given less than an hour to assemble, transport, and set up their equipment; not to mention the fact that each piece of apparatus must be thoroughly checked before going on the air. Small wonder, therefore, that this type of work attracts the more adventurous engineer, the chap who craves excitement and always manages to get it, whether he's riding gain at a thrilling college football game or keeping a sharp eye on the plate meter while hurtling through the clouds at four hundred miles-per-hour.

(Continued on page 155)

Operator at work on the central master control board of a major network. Here incoming programs are integrated, checked, and channelled off into lines feeding transmitters, small master controls of outlying stations, and various recording companies.

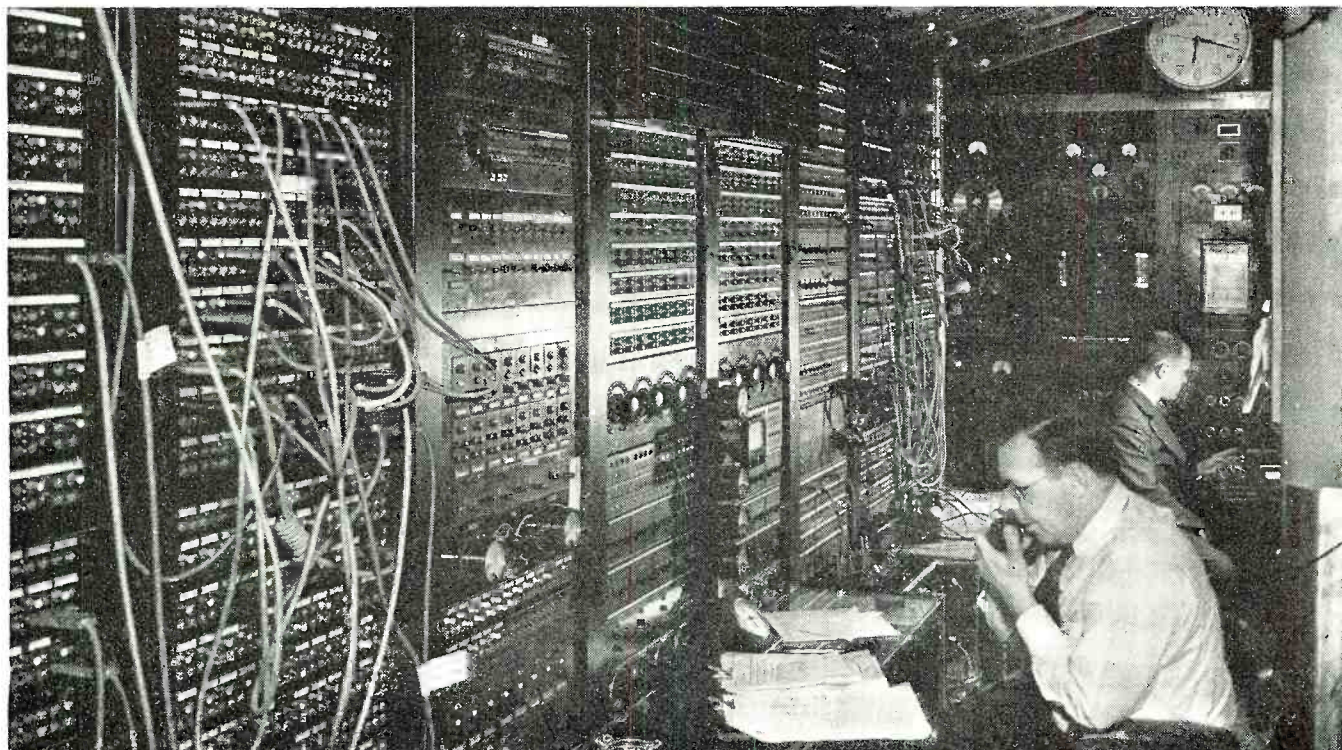



# R.F.-I.F.-A.F. Signal Tracer

By Vincent Cavaleri

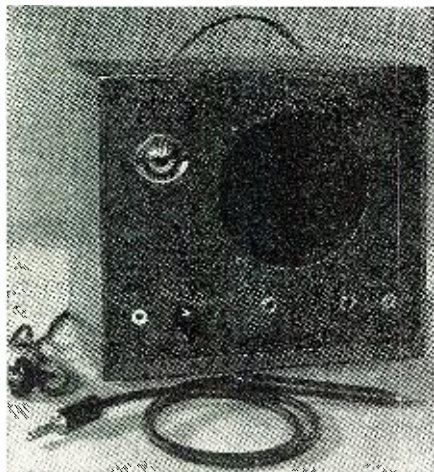

Panel view of the completed instrument.

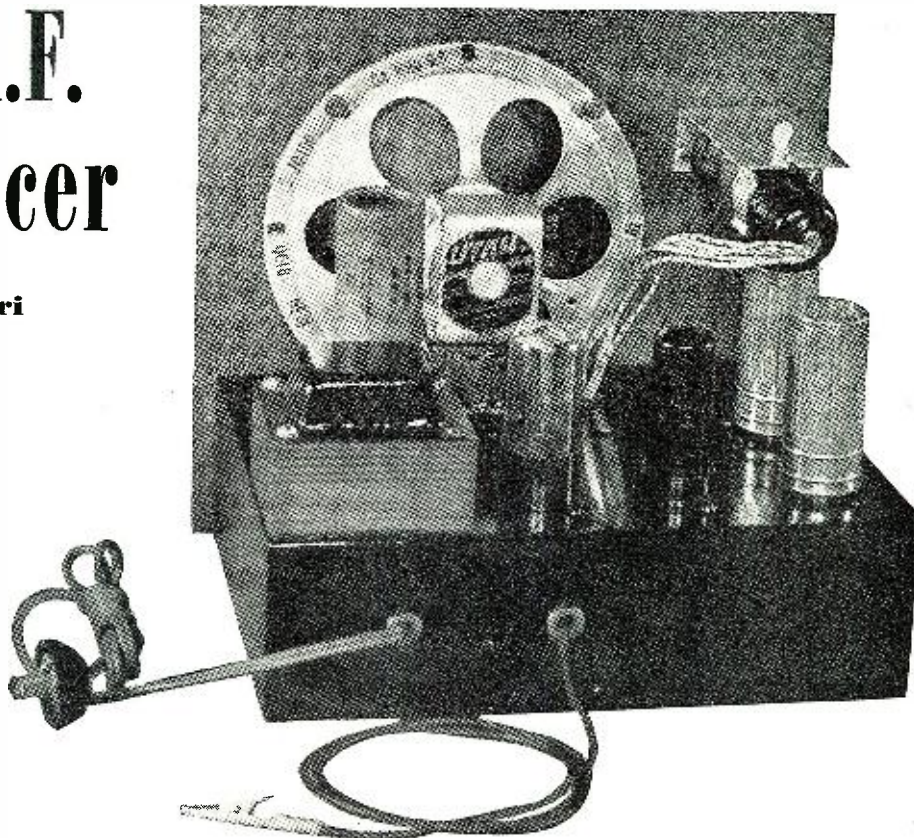

Rear view shows proper placement of component parts mounted on the chassis and front panel. Ground lead with alligator clip is shown extending from rear of chassis.

**For the novice or serviceman, this inexpensive, compact, and easy-to-construct test instrument will prove invaluable in servicing radio receivers.**

HERE is a signal tracer that is inexpensive to construct, easy to build, and extremely simple to operate.

In the school shops at Radio Maritime School, New York City, are several types of signal tracers which are more or less elaborate. They are equipped with multi-band coils, multi-switching arrangements, etc., and, therefore, have quite a few controls to manipulate. To the trainee entering the field of radio, these signal tracers may be difficult to master, and this difficulty is doubled by the fact that there are two distinct problems to contend with: the signal tracer and the receiver being tested. Obviously, the simpler the testing device, the easier it will be for the beginner to locate receiver troubles.

Since the newcomer invariably wishes to own a signal tracer, it would be best at the start to build one, as new ones are still difficult to obtain. To build a tuned type of signal tracer is a difficult job. The coils required cannot easily be obtained. Even if all the required parts could be purchased, the complete unit would be

rather expensive for many, not to mention the headaches that would beset a novice in its construction. With that thought in mind this article was prepared and describes an instrument that does not require the use of tuned circuits, nor switching arrangements; not even a tube in a probe! Yet this instrument, with only a single control, fulfills the requirement for troubleshooting—that of signal tracing a receiver completely, from antenna to speaker.

### Circuit Description and Operating Principles

Examine the circuit (Fig. 1) and you will see that fundamentally it is a high-gain audio amplifier. Let us start from the input. A shielded cable and probe is used for all tests. Ordinary microphone cable will do. If a coaxial cable can be obtained, so much the better. In the probe handle is a .00025  $\mu$ fd paper condenser. It is about a quarter inch in diameter and will easily fit in the prod. An old principle is used in the grid circuit: grid leak detection. The grid leak becomes a one-megohm volume control which is

used in conjunction with a 50  $\mu$ fd. mica condenser. When the probe is applied to an r.f. grid or plate circuit, the signal is rectified. The signal is amplified by the 6SQ7 tube. The 50  $\mu$ fd. plate condenser  $C_3$  is used for partial r.f. filtering. The signal is further amplified by the 6J5. A portion of the r.f. ripple component is applied to the diode plates of the 6SQ7 through  $C_9$ . This is filtered through  $R_{10}$ ,  $C_{10}$ , and operates the 6E5 magic eye tube. The audio component is amplified by the 6V6 beam power tube, which operates the speaker.

When testing unmodulated r.f., such as the local oscillator of a superhet, no sound will be heard from the speaker, but the magic eye will close, thus detecting its presence.

When the probe is applied to an audio circuit, the input becomes a contact potential biased affair. The 6SQ7 automatically becomes biased for audio amplification.

The power supply is of the conventional type. A decoupling filter,  $R_8$ ,  $C_8$ , is used to prevent motorboating.

The magic-eye assembly can be purchased complete with resistor  $R_{11}$ , built in the base. The power transformer used is a Utah VPT $\frac{1}{4}$  50-ma. transformer with a 300-0-300-v. secondary. The speaker used is a 6-inch Utah with a field of 1800 ohms. The speaker is equipped with a universal output transformer with output taps for matching to the 6V6 power tube. Any



separate output transformer matched for a 6V6 tube is suitable. An ordinary piece of masonite board was used for the panel; however, the builder may use a metal panel if he desires. Two phone jacks are provided, one for the signal tracing input and the other for microphone and phono pickup tests.

### Constructional Details

Drill and punch all holes in the 7" × 10" × 3" chassis as shown in Fig. 2. Cut away the chassis to allow room for the speaker frame. Next, drill holes in the panel for the volume control, jacks, magic eye, and speaker, as in Fig. 3. Mount all parts on the chassis. The panel will be secured to the chassis with the mounting nuts on the control and phone jacks. The speaker will aid in making the panel rigid when it is mounted flush to the panel. Wire all filaments first with twisted leads to prevent hum radiation. The order in which the rest of the circuits are wired is not critical. The use of tie lugs will help in neatness and convenience of wiring. It is important, however, to use shielded wire for the input circuit of the 6SQ7 tube; otherwise, feedback will occur. The center phone jack will be used for the probe cable. The extra microphone jack has been added so that, if desired, the instrument may be used as a conventional audio amplifier. The magic-eye assembly is mounted above the 6SQ7 tube. There is enough clearance to remove the 6SQ7 for tube-testing purposes. If a metal 6SQ7 cannot be obtained, a glass tube will do; but don't forget the tube shield—it is a necessity.

The construction of the cable is fairly easy. A phone plug is connected at one end. The probe end will have the .00025 μfd paper condenser in it. This condenser is about a quarter inch in diameter. If the hole in the prod is too small, drill with a 19/64" bit to allow for clearance.

Check all wiring carefully after completion. If the job has been well done, the tracer should not cause any grid hum with the control full on.

The signal tracer is now ready for use.

### Application

Turn on the signal tracer and permit it to warm up for a few minutes. Attach the ground lead of the tracer to a receiver that is to be tested. Connect a good aerial to the receiver. Let us assume that it is a conventional superhet. If the tracer probe is placed on the antenna, several stations will be heard at the same time. Now apply the probe to the signal grid of the 6A8 mixer stage. Rotate the receiver condenser gang. Stations can now be separated and heard in the tracer. Lack of signals would indicate trouble in the tank circuit of the antenna coil. Next, apply the probe to the oscillator grid of the 6A8 tube. If the oscillator circuit is op-

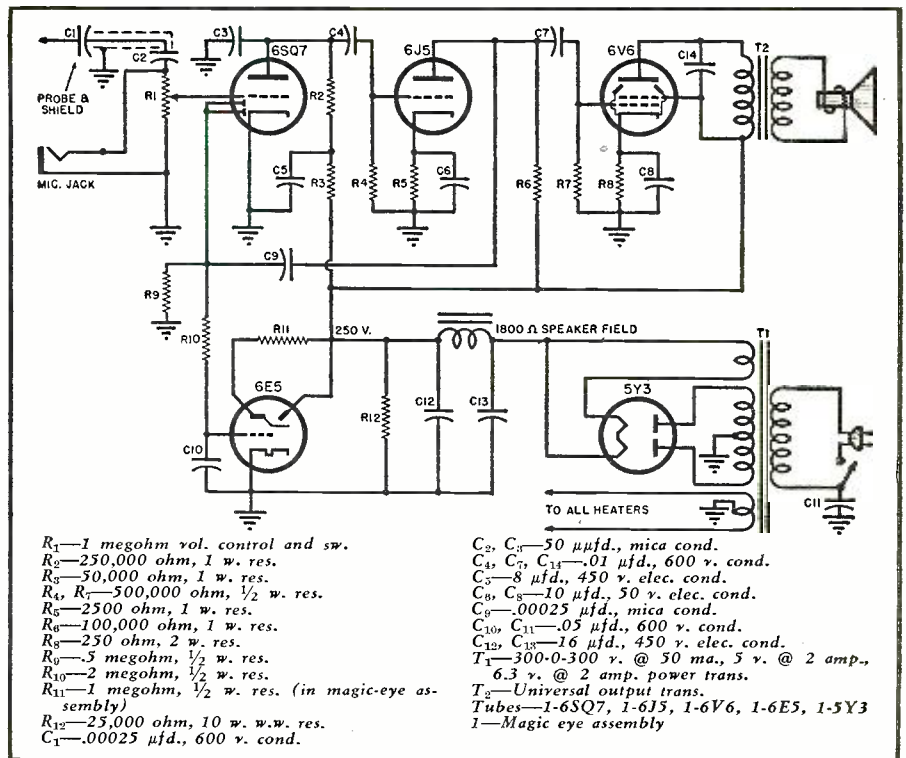
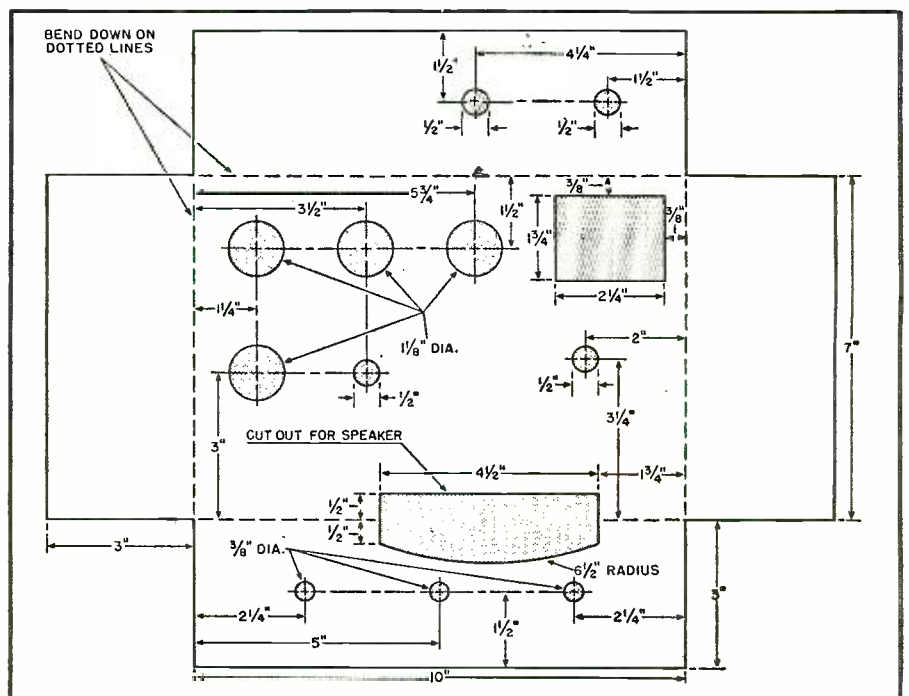

Fig. 1. Wiring diagram of test instrument. A single probe is used for testing all r.f., i.f., and audio circuits. For r.f. and i.f. tests the input circuit acts as a grid leak detector thus rectifying the signal. On all audio tests the input circuit acts as a contact potential biased amplifier.

erating properly, the magic eye of the tracer will close. If the local oscillator is dead, the eye will remain open. The next step is to test the plate of the 6A8. Rotating the receiver gang will bring in many stations. Now apply the probe to the i.f. amplifier grid (6K7 tube). Again stations should be heard. Now apply the probe to the i.f. amplifier plate. If all is

normal, the signals heard through the tracer will now be very strong while at the same time the eye will close. Turn down the volume control of the tracer if necessary. The stronger the signal carrier, the greater will be the deflection of the tracer eye and the louder the signal heard. Lack of signals at this point would indicate a  
 (Continued on page 132)

Fig. 2. Mechanical layout of the chassis shows the various holes and cutouts necessary for proper mounting and placement of component parts.





# TELEVISION SWEEP OSCILLATORS

By Edward M. Noll  
Television Tech Enterprises

## Part II. The theoretical design and operation of sweep oscillators used to generate sawtooth voltages in television receivers.

THE sweep oscillators of the television receiver generate the sawtooth voltages which, after subsequent amplification and shaping, deflect the picture tube beam. The sawtooth output voltage of the sweep oscillator contains two rates of voltage change, an essentially linear rise of voltage and a more rapid decline of voltage. The rise in voltage of the horizontal sawtooth moves the beam across the screen left to right (facing the front of the picture tube) and the faster decrease snaps it back to the left side. In the present commercial system this horizontal cycle occurs 15,750 times per second. In the television system there is also a much slower sawtooth, 60 times per second, which moves the beam vertically down the screen, and more rapidly returns it again to the top. Thus, as the picture tube beam is deflected rapidly back and forth across the screen by a horizontal sawtooth, it is also gradually moved down the screen by a vertical sawtooth. For a more complete

Fig. 1. Derivation of a sawtooth voltage from the exponential rise of a voltage across a capacitor.

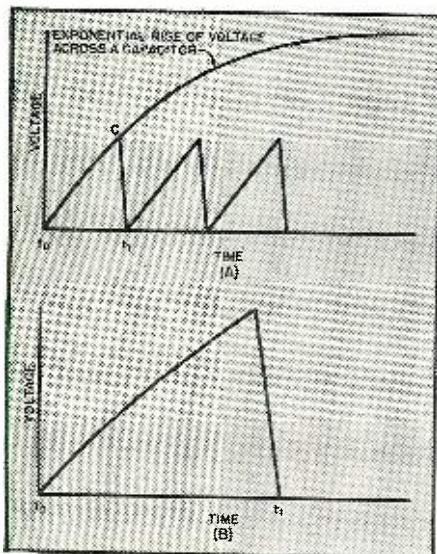

discussion of deflection and interlaced scanning, review installment two.

With a picture tube having electrostatic deflection plates, an amplified sawtooth voltage is applied directly to the deflection plates; with a picture tube having electromagnetic deflection coils, a sawtooth of current is applied to the deflection coils. However, the sawtooth generators, both horizontal and vertical, generate sawtooth voltages directly under control of the received horizontal and vertical sync pulses. Formation of a current sawtooth from the voltage sawtooth for deflection coils will be discussed in a subsequent issue. The sawtooth oscillators continue to function whether sync pulses are applied or not. When not controlled by sync pulses, the generators are said to be "free-running." Consequently, with receiver on but no received signal, the sawtooth voltages deflect the beam, producing the so-called scanning raster on the fluorescent screen. When a signal is received, the sweep generators are synchronized or "in sync" with the pulse generator at the transmitter. This means that the cathode-ray beams of picture and pickup tubes are directed at all times onto the same relative positions on their respective scanning rasters.

### Formation of a Sawtooth

A voltage sawtooth is formed by utilizing a portion of the charging cycle of a capacitor. The charging cycle of a capacitor or rise in voltage across the capacitor is exponential (Fig. 1A), not linear. Therefore, the rate of voltage change is gradually decreasing, causing the beam to travel at a decreased velocity. For a faithful reproduction, the beam, of course, should move with a constant velocity to prevent crowding on the right side of the screen. This defect would cause a person moving from left to right across the screen to appear progressively thinner. To obtain a more linear sweep, only the initial essentially linear portion of the capacitor

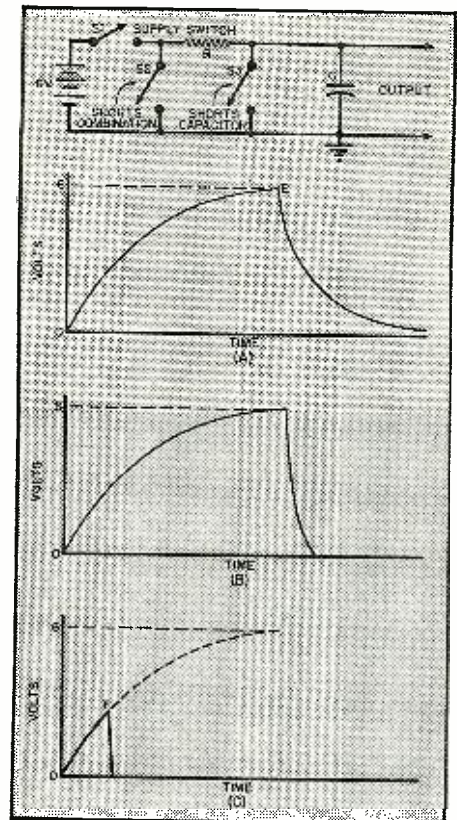

Fig. 2. Formation of a sawtooth voltage.

charging cycle is used. Thus, if the capacitor is permitted to charge only to point C, Fig. 1A, and then is discharged, a better, more linear sawtooth is obtained. After amplification, it appears as shown in Fig. 1B. Point C generally represents approximately five to ten per cent of the capacitor charging cycle.

The formation of a sawtooth can be conveniently explained with the simple circuit of Fig. 2. When the supply switch,  $S_1$ , is closed (switches  $S_2$  and  $S_3$  remain open), the capacitor, C, begins to charge through resistor R. The time required to reach peak amplitude, point E of Fig. 2A, is dependent on the time constant of the capacitor and resistor. The larger the resistor, the more time it requires to charge the capacitor, because the rate of current flow is limited by the size of the resistor. Likewise, the larger the capacitor, the more time it requires to fully charge it. Now, when switch  $S_1$  is opened and switch  $S_2$  is closed, the capacitor will discharge through the resistor; the discharge time is the same as the charging time and is dependent on the time constant of the capacitor and resistor.

To shorten the discharge time, it is possible to short circuit the capacitor instead of discharging it through the resistor. Thus, if at the time  $S_1$  is opened, switch  $S_3$  is closed, the capacitor quickly discharges (Fig. 2B) through the low resistance path to ground presented to the capacitor by the closed switch.

To develop a more linear sawtooth, it is necessary to open  $S_1$  and close  $S_3$



before the capacitor has had time to accumulate a full charge. Thus, as shown in Fig. 2C, the capacitor is only charged to point *F* and then switch *S*<sub>1</sub> is opened and *S*<sub>2</sub> closed, quickly discharging the capacitor to zero volts. In practical sawtooth oscillators, the switching is undertaken by a gas or high-vacuum tube, which also has some feedback arrangement to keep the oscillator in continuous operation.

### Gas Tube Oscillator

The three types of sawtooth oscillators commonly used in television receivers are the gas discharge oscillator, multivibrator, and blocking tube oscillator. The gas discharge tube operation, Fig. 4, is dependent on the ionization of the gas in the tube. When the supply voltage is first turned on, capacitor *C* begins to charge through resistor *R*<sub>1</sub>. As the capacitor charges, of course, the plate voltage rises on the gas tube until it reaches a potential at which the tube gas ionizes. The ionized gas now presents a very low resistance path to ground which shunts the capacitor and quickly removes the charge. In removing the charge, the plate voltage has fallen and the gas tube de-ionizes. Now, capacitor *C* again begins to charge through *R*<sub>1</sub>, initiating a new cycle. The plate voltage level at which ionization occurs is set at a level which does not permit the capacitor to charge to the non-linear portions of its charging cycle, the gas in the tube ionizing before the capacitor voltage builds up to the non-linear portion. This is accomplished by using the correct control grid bias, for the less bias on the grid the lower is the plate voltage level at which the tube ionizes. Thus, in the circuit of Fig. 4, cathode resistors *R*<sub>2</sub> and *R*<sub>3</sub> set the tube bias and therefore determine the ionization level. Now, if the bias is varied over a limited range by resistor *R*<sub>3</sub>, the ionization level and, consequently, the frequency of the sawtooth are varied. This becomes apparent when it is considered that the voltage level of the charging cycle at which ionization occurs has been lowered. Therefore, the frequency of the sawtooth increases, because the capacitor charges to this lower level more often in a given time.

The free-running gas tube can be synchronized by applying a positive pulse to the control grid, instantaneously decreasing the bias. Thus, as the plate voltage is climbing to, and is near to, the ionization level, a positive pulse on the grid will cause the ionization level to fall and the tube to ionize at the instant the pulse is applied. Inasmuch as the ionization point represents the point at which the beam begins its retrace, the positive sync pulses applied to the grid not only lock in the oscillator at correct frequency but also tie in the position of the beam in its sweep cycle with that of the pick-up tube sweep. A more detailed coverage of synchro-

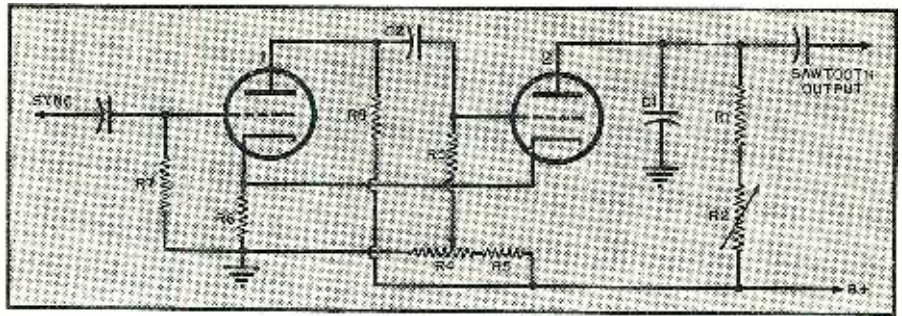

Fig. 3. Multivibrator-type sawtooth generator.

nization is given in the discussion of the blocking tube oscillator. Resistor *R*<sub>1</sub> is a safety device preventing excessive current flow when the tube ionizes.

In the multivibrator circuit, Fig. 3, feedback action between two tubes first permits one tube to conduct, then the other. When the second tube is not conducting, capacitor *C*<sub>1</sub> will charge through resistors *R*<sub>1</sub> and *R*<sub>2</sub>.

To understand the operating cycle, first assume grid two is swinging positive. This means that tube two draws more plate current, and since this plate current is drawn through cathode resistor *R*<sub>5</sub>, which is common to both tubes, a negative bias is applied to tube one. A decrease in bias on tube one causes it to draw less current, decreasing the voltage drop across *R*<sub>5</sub> and increasing tube one plate voltage. The increasing plate voltage, coupled through capacitor *C*<sub>1</sub>, is felt as a further increase in grid voltage on tube two. This feedback cycle occurs almost instantaneously, driving grid two positive and cutting off tube one. It appears as though the cut-off bias developed across resistor *R*<sub>5</sub> would also cut off tube two; however, tube two has additional positive grid voltage obtained from the power line divider, *R*<sub>1</sub> and *R*<sub>2</sub>.

The positive sweep of grid two continues until a further increase in grid voltage causes no further increase in plate current, or until tube one has reached cut-off and there is no further increase in plate voltage to couple through capacitor *C*<sub>1</sub>. At this instant when no further feedback occurs, the grid voltage of tube two begins to fall, causing tube two plate current to fall, tube one bias to decrease, and tube one

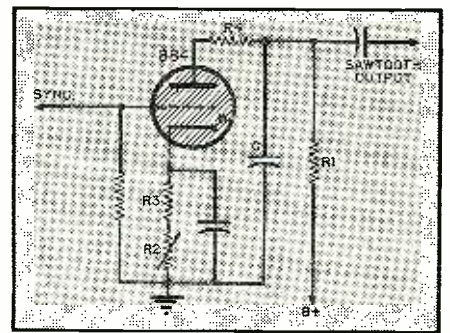
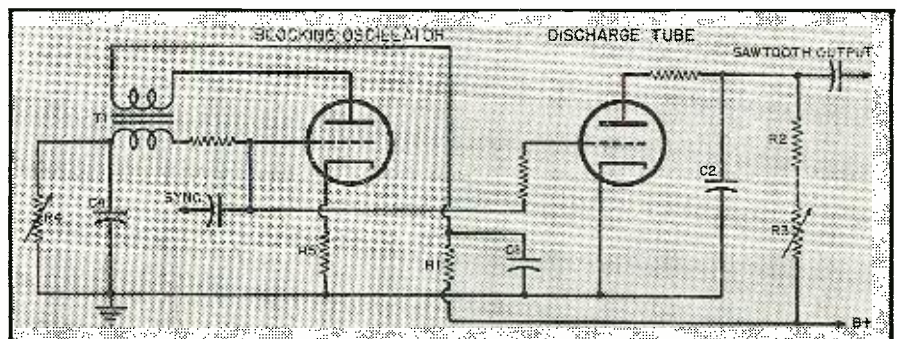

Fig. 4. Gas-tube sawtooth generator.

plate voltage to decrease. The negative plate voltage swing reinforces the original fall of tube two grid voltage, driving the grid far negative almost instantaneously. Actually, the grid is driven far beyond cut-off by the pronounced drop in tube one plate voltage. In fact, it is driven so far negative that there is a certain interval during which tube two is cut off and tube one draws a constant current until the negative charge has leaked off capacitor *C*<sub>1</sub> through resistor *R*<sub>3</sub> to the level at which tube two begins to conduct. Since grid two has been going positive to reach its point of conduction, a new cycle of oscillation begins at the instant grid two reaches the conduction point, originating a new feedback cycle which drives grid two far positive and grid one negative.

During this discharge interval, the length of which, of course, is determined by the time constant of *C*<sub>1</sub> and *R*<sub>3</sub> plus tube two plate voltage, capacitor *C*<sub>1</sub> has been charging through resistors *R*<sub>1</sub> and *R*<sub>2</sub>. This combination has a longer time constant than *C*<sub>1</sub> (Continued on page 72)

Fig. 5. Blocking-type oscillator producing a sawtooth voltage output.





# R. F. CHOKES

## at u.h.f

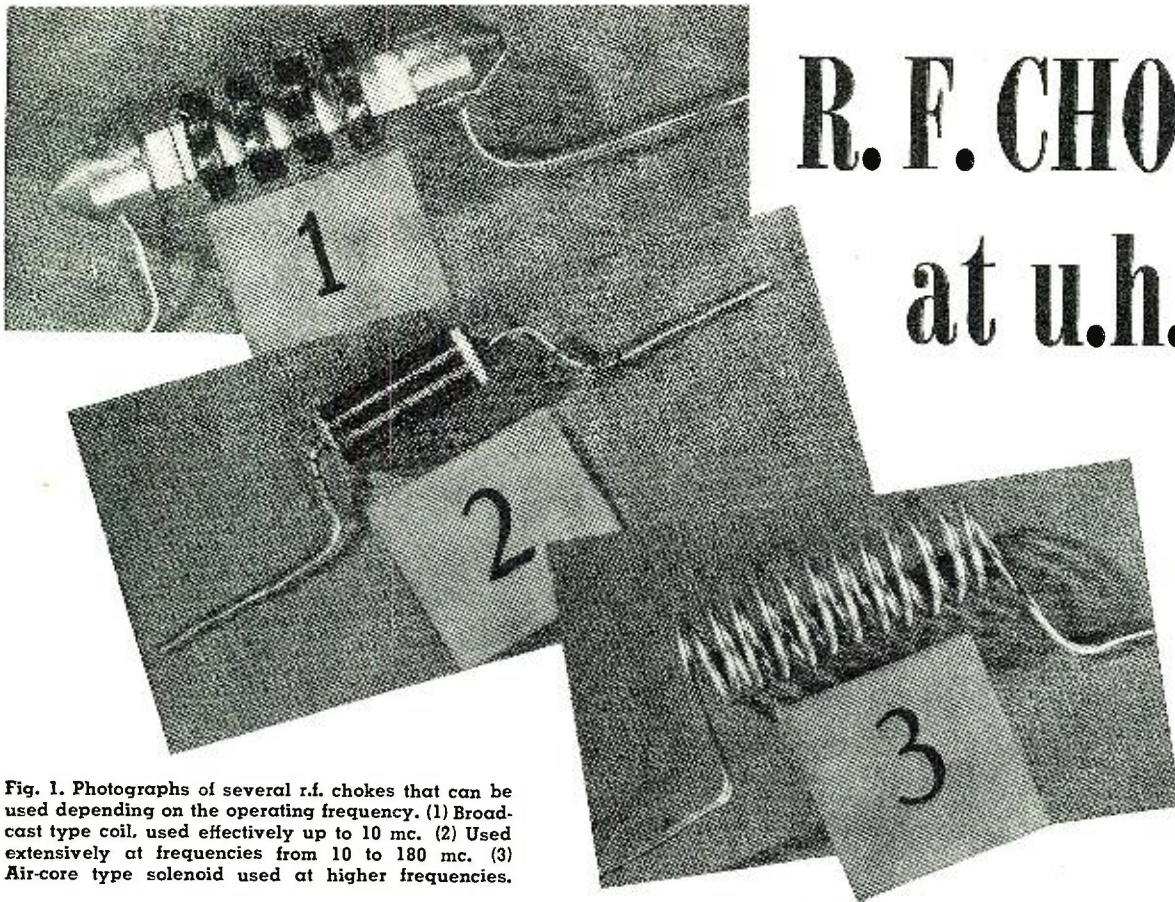

Fig. 1. Photographs of several r.f. chokes that can be used depending on the operating frequency. (1) Broadcast type coil, used effectively up to 10 mc. (2) Used extensively at frequencies from 10 to 180 mc. (3) Air-core type solenoid used at higher frequencies.

**With the assignment of many services to higher frequencies, the electrical characteristics of component parts must be carefully analyzed.**

By  
**W. J. STOLZE**

WITH the advent of FM and television, the radio serviceman, who for the past twenty-odd years has been ably repairing amplitude-modulated (AM) broadcast receivers, must now familiarize himself with good design and construction technique in the recently assigned high-frequency bands. A thorough working knowledge of the various problems which become apparent at high frequencies will not only increase the pleasure that a radio amateur can extract from his hobby, but will also be very profitable, for in the immediate future the majority of sets brought into the small service station for repair will be high frequency FM and television receivers. With an eye to the future, this article will discuss the design and application of radio frequency chokes in the new v.h.f. bands.

The proper selection of a correct r.f. choke, even though often ignored, misunderstood, and underemphasized, is an important factor in obtaining the best possible performance from a well-designed unit of equipment. The most important circuit application of the

choke is in series with the B+ plate voltage supply of high-frequency oscillators. In Fig. 3A a typical FM local oscillator is shown. The choke, *RFC*, is inserted in series between the plate of the tube and the B+ voltage supply. At the frequencies used, if this choke were not present a portion of the available power output of the oscillator would be dissipated in the plate power supply. This is a serious situation when maximum power output is required. The condition can be equated as follows:

$$\text{Power Output} = \text{Power Available} - \text{Power Dissipated}$$

A typical circuit uses the 6C4 and is capable of delivering about four watts maximum output. With improper choking, as much as two watts may be lost in the power pack, leaving only two watts, or 50% maximum power, available as useful output. This condition also exists and is even more serious in high power transmitter oscillators.

Fig. 3A also includes a choke, *RFC*, in the grid-leak circuit. Most setups require this choke, as its omission may

be cause for the oscillator to cease operation. A diagram of the typical grid-leak resistor is shown in Fig. 3B. A carbon rod forms the resistive element, which is flanked on each side by small round metal plates, *A* and *B*, from which the terminal leads are brought out. Bakelite or ceramic covering is added as insulation. A stray capacity exists between these plates, *A* and *B*, which at high frequencies may be of such magnitude as to by-pass enough of the signal from the grid to ground to prevent oscillation.

In the 200 to 600 megacycles per second section of the frequency spectrum, transmission lines make their appearance as tuned circuits for power oscillators. At these frequencies another problem appears. High percentages of the power may run down the leads of the filament and be lost in the filament transformer. Correction of this condition is essential, since the same problem exists as did with improper plate supply chokes. Fig. 2A illustrates the application of r.f. chokes in the filament leads, and one of a number of correct methods



of grounding. As the frequency approaches 600 megacycles, and above, however, it becomes convenient to feed the heaters through tuned transmission lines, which then act as r.f. chokes.

Confining r.f. to particular sections of a circuit and eliminating it in other sections is another use to which r.f. chokes are put in modulating apparatus. In Fig. 2B a circuit for grid-bias modulation is shown. Here the r.f.c. prevents the r.f. from flowing in the modulating transformer.

Of course there are many other applications of r.f. chokes, but those which are most important and those which the average radio serviceman or radio ham are most likely to encounter have been included in the above discussion.

An important characteristic of chokes which is very often forgotten or ignored is that the choke must be a very high impedance at the operating frequency and not just a high inductance. If this condition is not fulfilled a serious detuning of the tank circuit may result. This statement at first appears paradoxical, but can be easily explained with reference to Fig. 5. It shows a number of coils of wire wrapped around a bakelite form. Small capacities (distributed) exist between each pair of turns on the coil. Classically a condenser consists of two flat plates of a conducting material separated by an insulating dielectric. In this case the two turns of wire form the plates and the interspace air forms the insulator. A condition of this nature exists with every coil. Even though the distributed capacity is small, it is impossible to make it zero; therefore, the optimum in choke design appears when the inductance of the coil resonates with its own distributed capacity at the operating frequency.

In actual practice, self-resonance is almost impossible to obtain exactly, because stray capacities which arise in the circuit wiring almost always detune the choke somewhat, but a condition as close as possible to the goal will pay the highest dividends. Too many turns will result in a very large stray capacity and, at a frequency any appreciable amount above resonance, the choke will appear to be a shunt condenser.

A Boonton Q Meter is an excellent instrument on which to measure resonant frequencies of chokes, but since such an instrument is expensive and therefore not available to the average amateur, several graphs are included to aid in the design of high-frequency chokes.

Other characteristics of chokes that are important are the current carrying capacity of the wire, which must be high enough for the desired application, and the resistance of the choke, which must be low enough not to cause an appreciable voltage drop.

Sketches of several chokes used at various frequencies are pictured in Fig. 1. Type 1 is used mainly in the

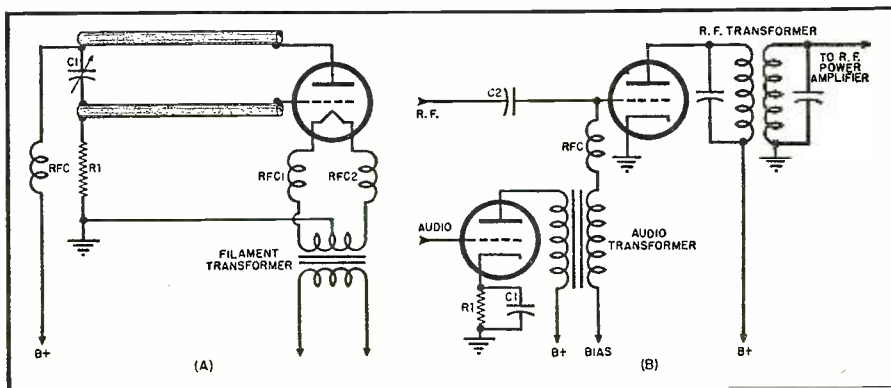

Fig. 2. (A) In higher frequency applications r.f. chokes must be employed in the filament circuits to prevent oscillations. Proper method of grounding is shown. (B) Circuit for grid bias modulation. R.f. choke prevents r.f. from entering modulation transformer.

broadcast band and up to approximately 10 megacycles. Construction of this of choke is difficult, as it necessitates the application of a universal coil-winding machine and is therefore out of the scope of most amateurs and radio builders. Choke number 2 is useful for frequencies from about 10 megacycles up to about 180 megacycles. Above this frequency, air-cored solenoids, type 3, are used.

Ceramic insulated resistors, with values ranging from 1 megohm up, provide the best form on which to wind a home-constructed choke. This material has about the least losses of any readily available. Isolantite is used commercially, but this is essentially the same thing. The 1-megohm resistance is high enough so that its effect upon circuit Q's is negligible. Another advantage of a resistor is that its terminal leads are excellent in facilitating the use of short connections.

All choke connections at high frequencies should be as short as it is possible to make them. This point cannot be overemphasized, as long leads add dangerous amounts of inductance and capacitance at the frequencies used in the new FM band.

An excellent illustration of this condition can be shown by the following  
(Continued on page 114)

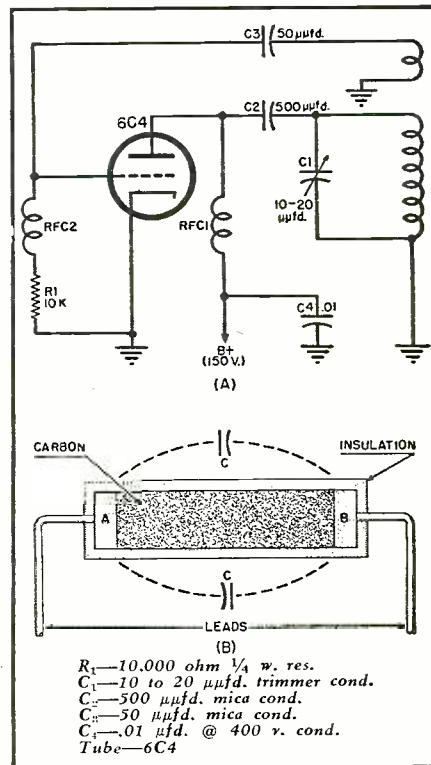
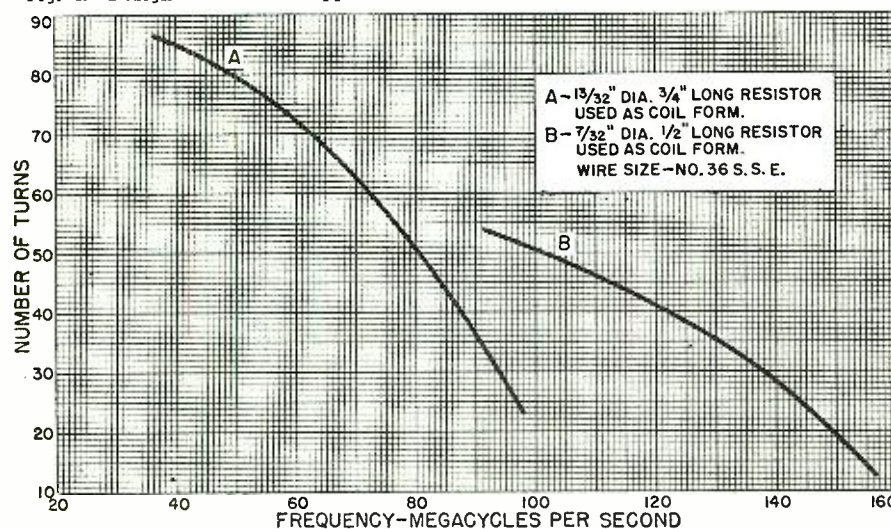

Fig. 3. (A) Diagram of FM local oscillator, shows most common grid application of r.f. chokes. (B) Common grid-leak type resistor.

Fig. 4. Design chart shows approximate number of turns vs. frequency for r.f. chokes.







By **CARL COLEMAN**

**A**MERICAN COMMUNICATIONS ASSOCIATION, Marine Department, is presently engaged in a nation-wide drive to develop support behind proposed legislation which will appropriately define the status of radiotelegraph operators as officers in the American merchant marine. This will be the third effort of the union to achieve this important recognition aboard merchant ships for radio officers.

The contribution made by this small but important group of men to the war effort should be in their favor. Merchant marine radio officers rose to the duties vested in them by virtue of the licensing requirements of the Federal Communications Commission. Radio operators have gained a record of loyal devotion to duty, both in peace and in war. Ofttimes their devotion to duty has been the cause of saving hundreds of lives at the cost of their own. Congressman Schuyler Otis Blan, addressing the House of Representatives on the subject "Radio officers in the American merchant marine," on June 8, 1943, stated: "They stand by the ship and keep to their post so long as there is a possibility of getting their signals through. They are among the last to leave the ship, and they leave only when there is no longer any possibility of getting a message through. The heroism of these men has been shown in many instances and repeated time and again."

On Maritime Day, 1944, Admiral Emory S. Land, chairman of the U. S. Maritime Commission and War Shipping Administrator, paid high tribute to radio officers when he said, "Our merchant marine operations, so important in this global war, could not function so smoothly or so effectively without the loyal services of its radio officers."

Further recognition of devotion to duty is given by the awarding of the

Distinguished Service medal in many instances by the President of the United States. On several occasions the War Shipping Administration has named vessels to honor those men who were lost at sea, serving "beyond the line of call to duty."

Congressional action on the important legislation being sponsored on behalf of all radio officers will bring the recognition to as gallant and deserving a group of men as can be found in any of our services. This recognition, long overdue, has been earned by their actions under fire. The most important responsibilities on board a merchant vessel are those connected with propulsion, navigation, and communications. The personnel charged with responsibility for propulsion and navigation, the master, mates, and engineers, have been given due recognition by being granted the rank of officer by Congressional legislation. The radio personnel, charged with responsibility for communications as well as some aspects of navigation, have been discriminated against, however, and not been given equal recognition as officers through Congressional legislation.

The vital responsibilities borne by radio personnel can be indicated by a brief description of radio officers' duties. They perform the work that

supplies a vessel with its sole link with snore, with other vessels, and with military craft. During adverse weather along coastlines, they are, in addition, the most dependable sources of navigational data through the use of ships' radio equipment. During periods of distress, radio officers are the only means of calling for assistance. They often save life and lessen suffering by summoning medical help by radio. They perform various supplementary functions of great value, such as obtaining time signals for navigational purposes. On many vessels radio officers are the only persons capable of repairing the sonic depth finders used for finding depth of water under the vessel when navigating in close waters. In wartime, radio personnel are often the only ones capable of repairing the Navy's ultra-high-frequency inter-ship radio telephone equipment and intra-ship battle-phones.

In asking for this recognition, radio officers are in the same position as were marine engineers many years ago. Originally, propulsion machinery was placed on sailing vessels as an auxiliary means of propulsion. The machinery was used when there was little wind, and for maneuvering in close waters. The men who operated and maintained the propulsion machinery were regarded as auxiliary, easily-dispensable-with personnel. However, steam eventually replaced sails and the importance of ship engineers was finally acknowledged when they were recognized as officers, on an equal basis with navigational officers, by Congressional legislation. Radio, like steam, has grown from an auxiliary curiosity to a vital ship installation. Its navigational, information, and communications functions, constantly expanding, make radio an ever more indispensable part of the vessel.

There is common acceptance of the fact that radar will be a usual and important part of future ship installations. Radio officers will therefore assume an even greater importance in the maintenance, and possibly in the operation as well, of this equipment. The U. S. Maritime Service has granted radio personnel the status of officers. Radio personnel who join the U. S. Maritime Service are rated as officers, they wear officers' uniforms and insignia. Radio personnel are recognized as officers legally in Great Britain . . . why not in the U. S. A.?

If you agree that Congress should define the status of radio officers, then you want to know what you can do about it. Write to your congressman and urge him to support legislation which will appropriately define the status of radiotelegraph operators as officers in the American merchant marine. This is of utmost importance to those of you who want to see this thing go through—get behind and push it along; to seagoing radiotelegraph operators it means a lot.

(Continued on page 141)

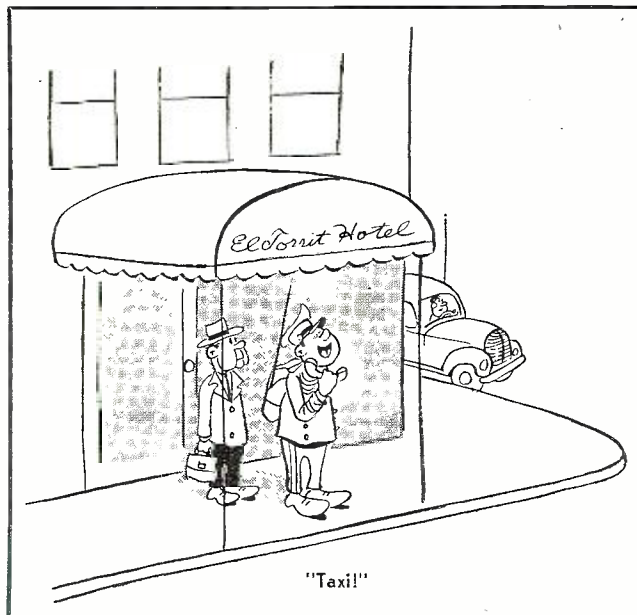



# Practical RADIO COURSE

## Part 40. The effects of resonant frequency "drifts" in the preselector, i.f. amplifier, and oscillator tuning circuits of a superheterodyne-type receiver.

By Alfred A. Ghirardi

**I**N ORDER that a superheterodyne receiver, whose tuning control (either manual or automatic push-button type) is set for reception of the signal of a particular desired station, shall provide the very best reception of which it is capable, the various tuning circuits of the preselector, oscillator, and i.f. amplifier must fulfill the following important requirements:

(1) The preselector tuning circuits must be tuned at least fairly close to the carrier frequency of the desired signal, so that this signal will get through to the mixer or converter tube with maximum strength and that all spurious responses will be rejected.

(2) The frequency of the oscillator output must be higher (or lower) than that of the desired signal by an amount *exactly* equal to the intermediate frequency to which the receiver's i.f. amplifier is designed

$$(f_o = f_{sig.} + f_i)$$

(3) The tuning circuits of the i.f. amplifier must be tuned so the center of their pass-band lies exactly at the intermediate frequency the receiver is designed to employ.

These conditions are illustrated in Fig. 1 for reception of a 1000 kc. signal by a receiver that employs an intermediate frequency of 455 kc.

### Initial Factory Adjustment of Receiver's Tuned Circuits

When a manually tuned receiver is given its initial preselector circuit *aligning* and oscillator *tracking* adjustments at the factory, the preselector, oscillator, and i.f. amplifier tuning circuits are adjusted to fulfill, as closely as possible, all three of the foregoing requirements. In push-button type receivers, however, the tuned circuits of the i.f. amplifier are adjusted to the correct intermediate frequency value at the factory, but the frequency adjustments for the pre-

lector and oscillator tuning circuits associated with each push-button are later set up at the owner's home, in order to make them conform with the foregoing frequency requirements for reception of the particular station that has been assigned to that push-button.

### Frequency Drift in Tuning Circuits

Unfortunately, the resonant frequencies of the preselector, oscillator, and i.f. amplifier tuned circuits are not likely to remain permanently at exactly these originally adjusted values. They are affected by any variations that may occur in the values of the inductance and capacitances present in the respective tuning circuits. Such variations may be caused by aging of the components, changes of temperature and humidity (especially the comparatively large change of temperature that occurs within the

receiver during the warm-up period for the first half hour or so after switching it on), shifting of wires or parts, etc. In addition, the frequency of the oscillator also may be affected by line voltage changes and by the oscillator or converter tube.

For the moment, we may disregard the causes of these various resonant-frequency drifts and proceed instead to a study of the *effects* of each upon the performance of the receiver. This will enable us to determine which ones are the most important, so that we may then proceed to study their causes and the best methods of reducing or compensating for them. It will be sufficient for the present to remember that the effects of *temperature* variations are perhaps the most important and, further, that in general the effect of *increased temperature* is to *increase* both the *L* and *C* in the resonant circuit and so *decrease* the resonant frequency.

Fig. 1. Various frequencies to which the preselector, oscillator, and i.f. amplifier resonant circuits should be tuned for reception of a 1000 kilocycle signal by a receiver employing an i.f. frequency of 455 kilocycles.

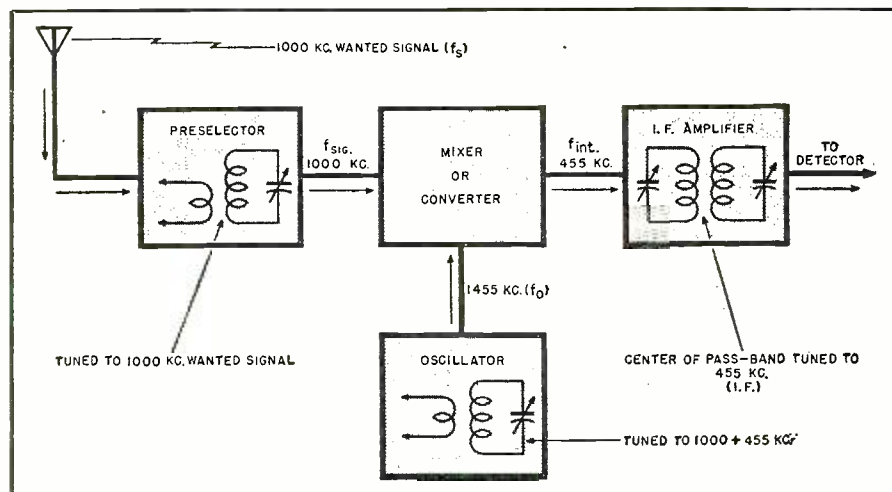



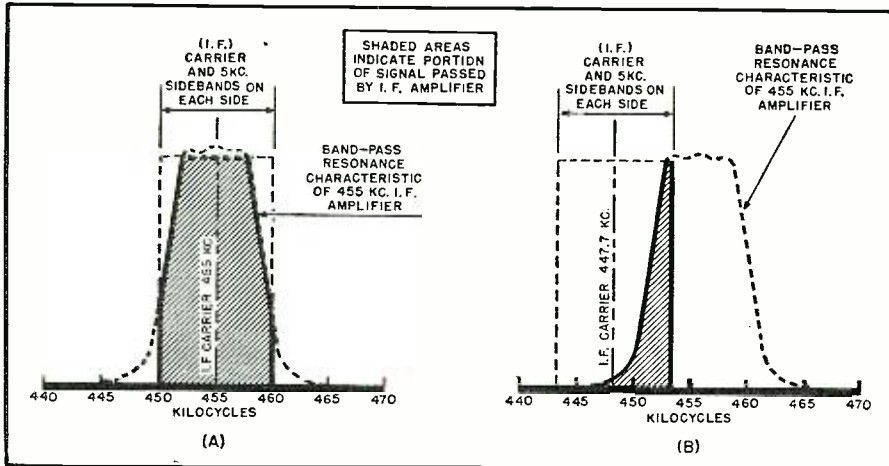

Fig. 2. The band-pass tuning characteristic of the 455 kilocycle i.f. amplifier of Fig. 1, and how a 455 kilocycle i.f. carrier and sidebands are passed by it with but little attenuation, as illustrated at (A). What happens when the oscillator frequency drifts .5% (to 1447.7 kilocycles) and the i.f. carrier frequency correspondingly drifts to 447.7 kilocycles is shown at (B). The signal is practically cut off.

From a practical point of view, drift in the resonant frequency of the preselector tuning circuits (for a given setting of the tuning control in a manually-tuned receiver, or given setting of the preselector tuning adjustment for each button in a push-button tuned receiver) does not present a serious problem. As reference to Fig. 1 will make clear, any small variation in resonant frequency that may occur in the preselector tuning circuits simply causes them to detune slightly from the frequency of the desired incoming signal passing through them. This will cause a slight reduction in the signal voltage applied to the mixer or converter tube grid. Comparatively speaking, the necessity of precisely tuning the preselector circuits is far less urgent than is that of accurately tuning the oscillator. If the preselector mistuning is appreciable, however, the signal of a strong station present on an adjacent channel may be allowed to get through the preselector

with sufficiently increased strength to cause some degree of adjacent-channel interference. This, of course, is undesirable.

By observing the ordinary practices of good tuning-coil and capacitor design and construction, the resonant-frequency stability of the preselector tuning circuits can be made sufficiently good so that no special frequency-stabilizing measures are necessary if the receiver is not likely to be operated under widely varying extremes of ambient temperature.

#### Effect of Oscillator Frequency

It is the oscillator tuning circuit which gives the greatest trouble, for, provided the desired incoming signal gets through the preselector tuning circuits satisfactorily, it is the frequency of the oscillator which determines what will be the frequency of the i.f. carrier put out by the mixer or converter tube and which is passed on through the sharply fixed-tuned i.f.

amplifier stages in which most of the gain in the receiver is secured.

Two of the most important requirements of the superheterodyne's oscillator are:

(1) Its frequency must always be the correct value for the signal to be received, so that it differs from that of the desired incoming signal by precisely the exact value of the chosen intermediate frequency (*i.e.*, so that  $f_i = f_o - f_{sig}$ ).

(2) Its frequency should remain constant for any particular setting of the receiver tuning control (either manual or automatic push-button). For example, in the superheterodyne illustrated in Fig. 1, the oscillator frequency should be  $1000 + 455 = 1455$  kc. if a 1000-kc. signal is to be received. The carrier frequency of the i.f. signal will then be 455 kc.—the same as the mid-frequency of the pass-band of the fixed-tuned circuits of the i.f. amplifier. The i.f. carrier and its sidebands will then proceed through the tuned circuits of the i.f. amplifier with little attenuation of the sidebands—as illustrated at (A) of Fig. 2—if the i.f. amplifier is designed to provide a sufficiently broad pass-band (usually 10 kc. total in the ordinary AM sound receiver).

If the oscillator frequency is too high or too low, then the frequency of the resulting i.f. carrier will be respectively *higher* or *lower* than the center frequency of the pass-band which the i.f. amplifier is fixed-tuned to accept. In a sharply-tuned i.f. amplifier, this results in considerable reduction in gain, as well as serious distortion of signal. This incorrectness of oscillator frequency may result from (1) inaccurate tuning of the receiver in the first place or (2) subsequent drift of the oscillator frequency due to any cause whatsoever, after the receiver has been tuned accurately to the signal.

To illustrate by an example, suppose that during the warm-up period in the first half hour or so, after the receiver of Fig. 1 is switched on and tuned to receive the 1000 kc. station, the frequency of the oscillator drifts *lower* by the not unlikely amount of .5 per-cent due to warming up of its tuning coil, capacitor, tube, etc. The oscillator frequency would now be  $1455 - (1455 \times .5\%) = 1447.7$  kc. The resulting i.f. carrier frequency now would be  $f_i = f_o - f_{sig} = 1447.7 - 1000 = 447.7$  kc. The i.f. carrier is therefore displaced 7.3 kc. from the mid-frequency of the 10 kc. pass-band of the i.f. amplifier tuned circuits. This is illustrated graphically at (B) of Fig. 2. The only sidebands of the i.f. signal that now get through the i.f. amplifier are those within the shaded area. Since the low-frequency sidebands have been attenuated, and the high-frequency sidebands on one side get through, the program being broadcast will sound shriller and higher-pitched than normal.

Careful study of this illustration

Fig. 3. How the i.f. carrier frequency is affected by oscillator drift to a lower frequency. (A) High-side oscillator operation and (B) low-side oscillator operation.

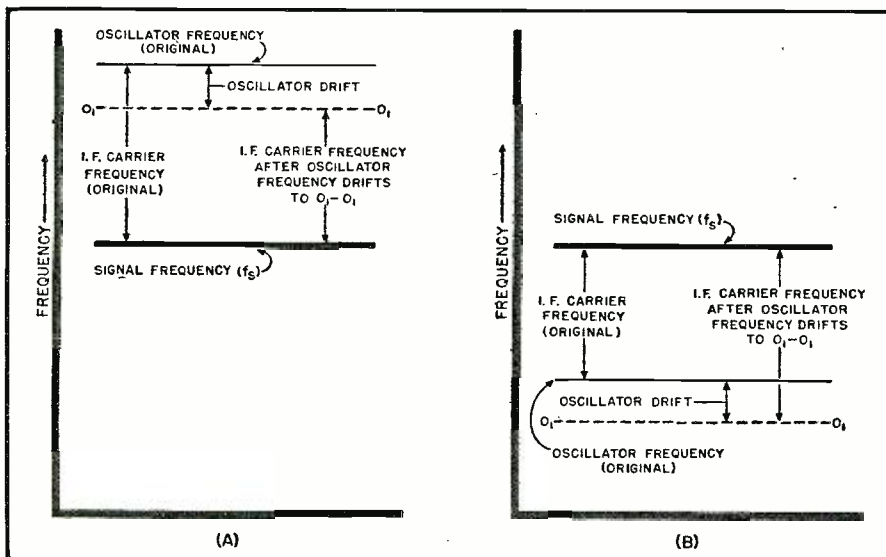



*Enduring Accuracy  
in Vital R.F. Applications*



# OHMITE RESISTORS & CHOKES

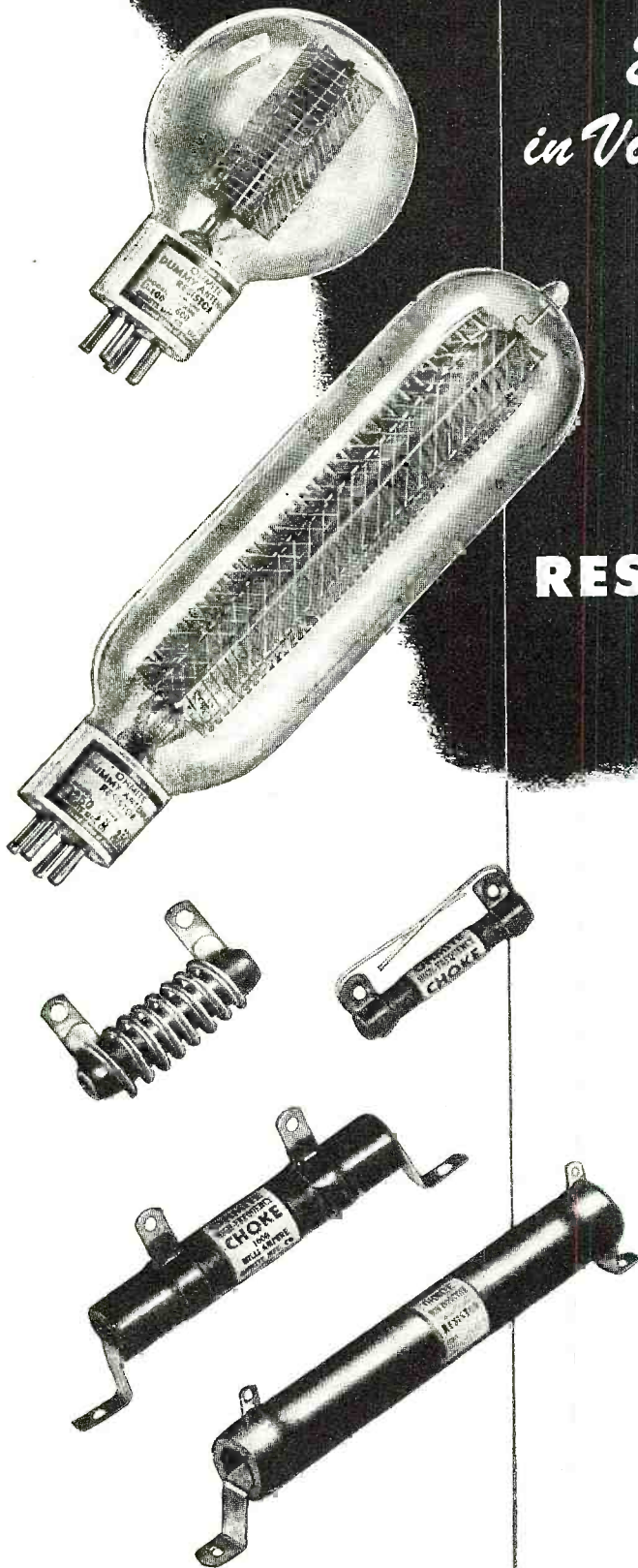

The unique characteristics of these Ohmite units have made them especially suitable for many r.f. applications. Proved by use before war came . . . they are performing vital functions today in the production and operation of critical equipment. Tomorrow—they will be more popular than ever!

**GLASS-SEALED NON-INDUCTIVE DUMMY ANTENNA RESISTORS**—for testing and measuring power output accurately. 100-watt and 250-watt sizes in variety of resistances.

**R. F. PLATE CHOKES**—single-layer wound on low power factor steatite cores, with moisture-proof coating. Built to carry 1000 M.A. 5 stock sizes from 2½ meters to 160 meters.

**PARASITIC SUPPRESSOR**—small, light, compact non-inductive resistor and choke, designed to prevent u.h.f. parasitic oscillations.

**NON-INDUCTIVE VITREOUS ENAMELED POWER-SIZE RESISTORS**—Useful in wide variety of radio frequency applications. 50-watt, 100-watt and 160-watt stock sizes in many resistances.

*Ohmite Engineers are glad to assist you on any resistance-control problem.*

**OHMITE MANUFACTURING CO.**  
4883 FLOURNOY STREET • CHICAGO 44, U. S. A.

**SEND FOR STOCK UNIT CATALOG 18**

*FREE—Helpful Catalog No. 18. Gives valuable data and information on stock resistors, rheostats, chokes, tap switches and other units. Write for your copy. Address Ohmite Mfg. Co., 4883 Flournoy St., Chicago 44, Ill.*

*Be Right with*  
**OHMITE**

**RHEOSTATS • RESISTORS • TAP SWITCHES**



# RADIO PARTS

# ELECTRONIC EQUIPMENT



## Mail Coupon NOW for **CONCORD** Victory Clearance Flyer . . . FREE!

● Ready now! 32 Bargain-packed pages listing thousands of standard-make, top-quality radio parts and electronic supplies—now available without priority at low VICTORY CLEARANCE prices. The values listed at the left are typical of the important savings offered in Meters, Condensers, Transformers, Resistors, Controls, Switches, Relays, Test Equipment, Generators, Microphones, Tools, and hundreds of Repair, Replacement, and Accessory Parts. On special requirements, Concord experts are ready to help you in expediting and speeding action on essential needs.

### Order Today for Shipment Tomorrow from **CHICAGO OR ATLANTA**

Huge stocks in TWO convenient warehouses—one in CHICAGO and one in ATLANTA—are ready to supply you quickly with needed parts of dependable, nationally-known quality—and at VICTORY CLEARANCE prices that mean real savings. Mail the coupon below NOW for your FREE copy of CONCORD'S VICTORY CLEARANCE Flyer.

**CONCORD RADIO CORP.**  
LAFAYETTE RADIO CORPORATION  
CHICAGO 7, ILL. ★ ★ ATLANTA 3, GA.  
901 W. Jackson Blvd. 265 Peachtree Street

### Check These Typical **CONCORD VALUES**



**D. C. Milliammeters**  
2 1/2" flange mtg. type. Metal case dull black finish. C. E. 0-200 M. A. C10650. Specially Priced . . . . . \$4.95

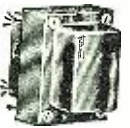

**Plate Power Transformer**  
Pri. tapped at 115, 117 and 120 V.A.C. Sec. output 850 V. at 200 ma. c. t. 4 1/2" L x 3 3/4" W x 3 1/2" H. 5B5035. Your cost . . . . . \$4.29

**Output Transformer**  
Hermetically sealed. Six studs. 1, 2, and 3 are pri. 4, 5, and 6 the sec. Pri. ind. at 5 V. 1000 cy.; .20 H. Ratio sec. to pri. 3.02:1. size: 3 1/4 x 2 41/64" 5B5045. Your cost . . . . . \$1.95



**Dry Electrolytic Condenser**  
Hermetically sealed. Size, 1 1/2" x 3". Can negative. Cap.: 40 mfd. at 475 volts; 15 mfd. at 350 volts; 15 mfd. at 150 volts; 20 mfd. at 25 volts. 5B3161 Each . . . . . 59c



**Mobile High Voltage Power Unit**  
Input 12 V. at 10 amps. Output consists of two voltage ranges: (1) 275 at 110 ma. (2) 500 at 50 ma. 5B9518 Your cost . . . \$39.50



**300 Watt Rheostat**  
Wire wound. Vitreous enameled. Cast aluminum base. 6" dia. 2 1/2" deep. 1400 ohms. 5B9517 Your cost . . . . . \$3.95

CONCORD RADIO CORPORATION  
901 W. Jackson Blvd.  
Dept. E-16  
Chicago 7, Ill.



Please RUSH FREE copy of CONCORD'S new 32-page VICTORY CLEARANCE Flyer.

Name . . . . .  
Address . . . . .  
City . . . . . State . . . . .

will reveal several important facts about the effects of oscillator frequency drift. Just how noticeable a given amount of this drift will be to the listener depends upon the selectivity of the i.f. amplifier. Should this be of the band-pass variety commonly employed in receivers of good audio fidelity, and having a flat-topped acceptance characteristic perhaps 5 or more kc. wide on each side of the resonance frequency, as illustrated at (B) of Fig. 2, then a shift of oscillator and resulting i.f. carrier frequency of 1 or 2 kc. from the center of the band-pass curve will not be very noticeable, although it will make the response to the two sidebands unsymmetrical and thus affect quality somewhat in an AM receiver. Much larger oscillator frequency shifts, however, will produce much more serious results. In the example illustrated at (B), the shift is so great that the i.f. signal is almost entirely rejected by the selectivity of the 455 kc. i.f. amplifier.

It can be seen that the narrower the i.f. pass-band width used, the more serious becomes the effect of any given amount of oscillator drift. Some sound receivers do not employ a band-pass i.f. characteristic of the type illustrated in Fig. 2, but use one that is sharply peaked (for good adjacent-channel selectivity), followed by a generally rising audio-frequency response to keep up the higher musical frequencies; in other cases, all the i.f. couplings are tuned to produce a single-peaked resonance curve of rather blunt shape. In communications type receivers a sharply peaked i.f. curve, or even a crystal filter combination, is intentionally used to provide razor-sharp, adjacent channel selectivity for interference-free long-distance reception. I.f. amplifiers having such peaked resonance curves are likely to attenuate appreciably at 2 kc. either side from resonance. When they are employed, the effect of oscillator frequency drifts and resulting i.f. carrier displacement even considerably less than 2 kc. would be most serious and would necessitate frequent re-tuning, for the signal might even fade out entirely unless the receiver was retuned to make the oscillator frequency the correct value for the signal to be received.

### Oscillator Frequency Stability Increasingly Important in Short-Wave Reception

Oscillator frequency stability becomes increasingly important in the short-wave reception. The minimum amount in kc. that the frequency drift of any oscillator can be held down to is a definite percentage of the oscillator frequency—this percentage depending upon the design of the oscillator components for a given oscillator. Consequently, the higher the oscillator frequency, the greater is the number of kc. of drift. Since the higher the frequency of the signal to be received, the higher must be the frequency of the signal produced by the oscillator,



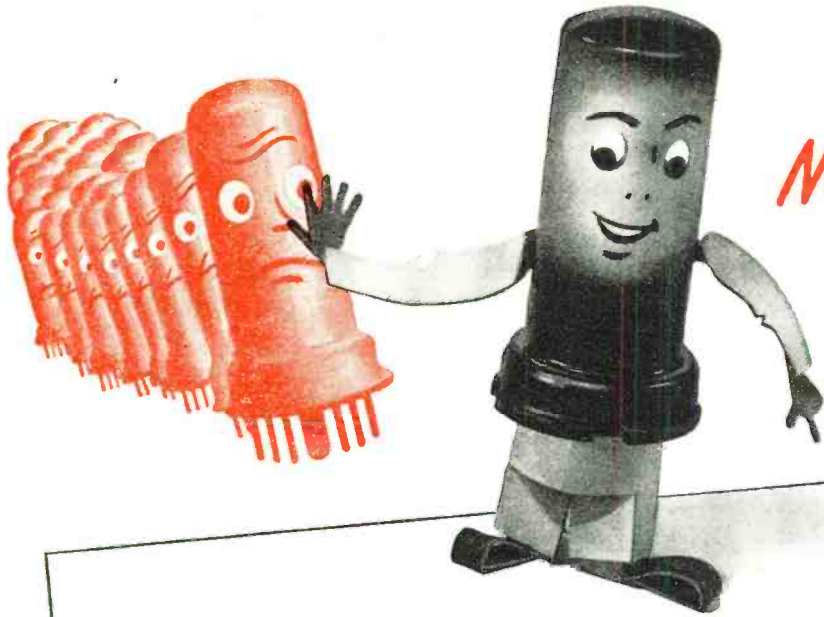

**NOW-** REPLACE OVER 875  
 TYPES OF BALLAST TUBES WITH  
 ONLY 10 N.U. UNIBALLASTS

# N.U. UNIBALLAST

**COVERS YOUR REPLACEMENT NEEDS WITH  
 ONLY 10 FAST-SELLING PROFITABLE TYPES**

**YOU BET** Uniballast are a real profit-maker for service men. With only 10 types of N.U. Uniballast to carry, you keep your investment constantly turning, and putting profits in your pocket. Order Uniballasts today from your N.U. Jobber. And ask him for the "N.U. Uniballast Service Manual" or write—National Union Radio Corporation, Newark 2, New Jersey.

### SPECIFICATIONS

- Uniballast—the universal ballast tube—small—compact—easy, quick installation.
- Metal envelope is excellent heat radiator. "Plug-in" simplicity.
- Provides proper operating current conditions regardless of variations in line voltage and in the characteristics of tube heaters and pilot lights.
- Even if one or more pilot lights burn out Uniballast continues to operate the tube filaments in the string, at efficient current range.
- Resistance is self-compensating—adjusts itself automatically—true ballast action. Voltage dropping range is indicated on every Uniballast.

## NATIONAL UNION RADIO TUBES AND PARTS

*Transmitting, Cathode Ray, Receiving, Special Purpose Tubes • Condensers •  
 Volume Controls • Photo Electric Cells • Panel Lamps • Flashlight Bulbs*



Actual size  
 Ov. Length 3 1/8"  
 Seated Ht. 2 11/16"  
 Diameter 1"

**Order Today from your N.U. Jobber**

January, 1946



Here's a soldering iron with . . .

**HEAVY  
POWER**  
(225 WATTS)







**LIGHT  
WEIGHT**  
(14 OUNCES)

made possible by  
**KWIKHEAT'S  
BUILT-IN  
THERMOSTAT**

- ★ HEATS IN ONLY 90 SECONDS
- ★ MAINTAINS PROPER HEAT
- ★ CAN'T OVERHEAT
- ★ LESS RETINNING NEEDED
- ★ TIPS LAST LONGER
- ★ COOL, SAFE HANDLE
- ★ LIGHT WEIGHT

The Kwikheat Soldering Iron has ample reserve power for your soldering jobs—225 watts held in check by a thermostat built right into the iron\*—maintaining ideal temperature for perfect soldering—preventing overheating (which causes deterioration in other irons)—prolonging life of tips and eliminating the need for constant retinning. Besides these big advantages, the Kwikheat Iron is hot, ready to use only 90 seconds after plugging in. It is extremely light (14 ounces), well-balanced, and has a safe, cool handle. No wonder Kwikheat is a sensation wherever it is used. Ask your jobber. With choice of #0, 1, 2, or 3 tips. \$11.00

**6 INTERCHANGEABLE TIP STYLES**

- |   |    |   |    |   |    |   |    |   |    |   |    |
|---|----|---|----|---|----|---|----|---|----|---|----|
|  | #0 |  | #1 |  | #2 |  | #3 |  | #4 |  | #5 |
| \$1.25  |    | \$1.25  |    | \$1.25  |    | \$1.25  |    | \$1.75  |    | \$1.25  |    |

\*patented

VANATTA



**kwikheat**

**THERMOSTATIC SOLDERING IRON**

A Division of  
Sound Equipment Corp. of Calif. • 3903 San Fernando Rd., Glendale 4, Calif.

the oscillator drift (expressed in kc.) will be greater the higher the signal frequency (shorter waves).

For example, let us consider a 500 kc. to 20 mc. all-wave AM receiver that employs a 455 kc. i.f. system. The oscillator frequencies required for receiving signals at the two extremes of its tuning range would be 955 kc. and approximately 20 mc., respectively. Now let us assume that the i.f. amplifier selectivity characteristic of the receiver is such that a 5 kc. deviation in the frequency of the i.f. carrier (or oscillator) frequency is the maximum permissible for satisfactory reception. This maximum allowable i.f. carrier and oscillator frequency deviation in kc. would be the same whether the frequency of the received signal is 500 kc. or 20 mc. In either case, a 5 kc. change in the frequency of the oscillator would have the same effect on the i.f. amplifier output.

Now a drift of 5 kc. would represent a .5 per-cent change in the 955-kc. oscillator operating frequency required for reception of the 500-kc. signal, but a change of only .025 per-cent in the oscillator frequency required for the 20-mc. signal. Since .025 per-cent is only one-twentieth as large as .5 per-cent, for equal tuning-drift effect upon the reception the allowable oscillator frequency variation (in percentage) for the higher frequency (20 mc.) signal is one-twentieth that for the lower frequency (500 kc.) signal. This means that the importance of building oscillators with good inherent frequency stability, or of providing effective counter measures to improve the frequency stability, becomes increasingly great as the frequency of the reception band of the receiver is increased. Thus the problem becomes especially important in television and other higher-frequency receivers.

The frequency-stability requirements in a superheterodyne—especially that of the oscillator—also vary with the *type* of receiver. In manually tuned receivers designed solely for reception on the standard broadcast band, the requirements are not so exacting as for the push-button type receivers, since in the latter the station is lost completely if the oscillator frequency drifts much and it cannot be brought back except by readjusting the oscillator-frequency adjustment screw provided for the particular push-button. The tolerable percentage oscillator frequency drift is even less in receivers designed for the higher frequencies, and in those civilian and military communications type receivers which employ razor-sharp adjacent-channel selectivity.

The resonance frequency of the tuning circuits in the i.f. amplifier is also subject to drift, in the same direction and for practically the same reasons as oscillator frequency drift. However, whether the i.f. drift adds to, or tends to compensate, the effect of the oscil-

(Continued on page 148)



# SPRAGUE TRADING POST

A FREE Buy-Exchange Service for Radio Men



## A PERSONAL MESSAGE TO EVERY USER OF THE SPRAGUE TRADING POST

With the gradual reappearance on the market of peacetime radio parts and equipment, it becomes obvious that the four-year-old Sprague Trading Post has outlived its usefulness. Rather than buy old materials, you will want factory-fresh new ones. Instead of trading obsolete equipment, you will now want to avail yourself of the many developments that wartime engineering has produced.

Thus, we are sure that the thousands of radio men, amateurs, experimenters, instructors and those in the nation's armed forces who have benefited through this free buy-trade-sell advertising service will fully understand our reasons for discontinuing it with the December issues of the six leading radio magazines wherein it has appeared.

In closing this chapter of Sprague cooperation with our friends throughout Radio, it is interesting to recapitulate briefly:

During the life of the Sprague Trading Post, approximately 12,000 individual classified advertisements were run absolutely free of charge. As a result, hard-to-get equipment was made rapidly available through those who no longer had need for it. Tubes, test equipment, manuals, receivers, transmitters, and dozens of other items including complete service shops were bought, sold and exchanged in tremendous quantity. So many ads were sent in to us that, on several occasions, we

\* Trademark Reg. U. S. Pat. Off.

had to increase our advertising budget in order to buy enough magazine space in which to accommodate them all. All told, we invested over \$70,000.00 to make this special wartime service as effective as was humanly possible.

What does the Sprague Products Company expect to get out of all of this? Well, the answer to that one is easy. It is simply that we believe that anything we can do to help our friends is good business for us. Now that Sprague Capacitors, \*Koolohm Resistors and Test Equipment are again becoming available in complete lines, we believe we can count on the loyal support of every radio man we tried to help when the going was tough. We believe we can count on you to use Sprague materials wherever possible—and if you do, we assure you that you will be getting the best, most dependable units money can buy.

Meanwhile, should any new opportunity for a cooperative service such as the Trading Post present itself, you can count on Sprague to render it to the utmost. Not only this, but I'll personally welcome suggestions and correspondence along this line from all of you who have benefited even a little through the Sprague Trading Post effort during the hectic wartime years.

*Harry Walker*  
SALES MANAGER

SPRAGUE PRODUCTS CO., NORTH ADAMS, MASS.

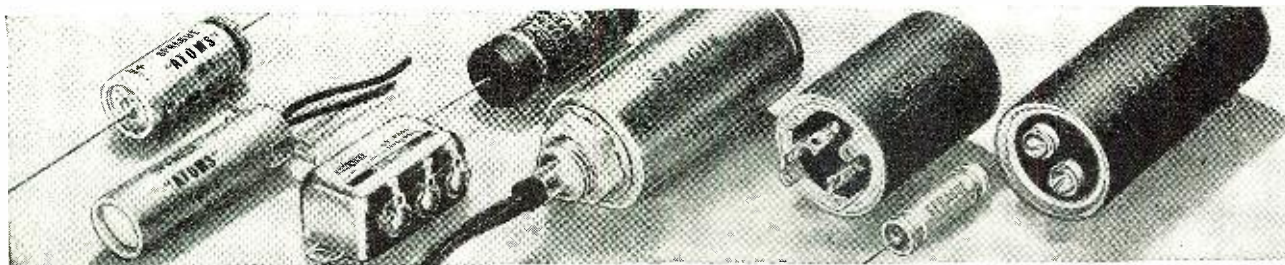

### CAPACITORS FOR EVERY SERVICE, AMATEUR AND EXPERIMENTAL NEED

January, 1946

63



# LISTENING To The WORLD

By

**CHRISTOPHER CROSS**

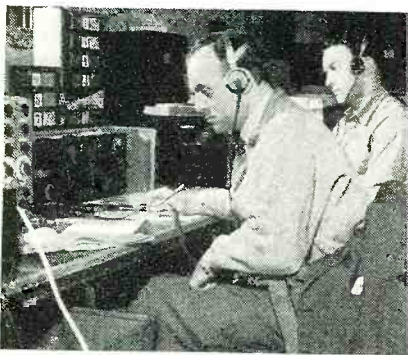

Hellschreiber and Morse Special Listening Section monitors at work. World-wide transmissions were monitored at all times.

Goebbels' instructions to his network of newspapers and broadcasting units were tapped by this BBC Hellschreiber machine.

**BBC's achievements in the development of its famous monitor service—equivalent to our own FBIS.**

**W**HEN Keren fell, it was the BBC's Monitoring Service that picked up the news in Arabic from a Cairo transmission and flashed it to Prime Minister Churchill ten minutes before the operational telegram from the War Office arrived.

When Mussolini resigned it was BBC's Monitoring that picked up the news in Italian at 22:51 and flashed it to the news department of the BBC at 22:53.

When Holland was invaded, Hilversum was putting out intermittently the announcements "Parachutists over . . . Parachutists coming down . . ." BBC's Monitoring Service got these messages through to the Air Ministry before the parachutists had even touched the earth.

Von Krosigk's broadcast announcing



The main listening room in which BBC monitors listen to transmissions from all over the world, in over thirty different languages. The numbered blocks, shown in the photograph, are to indicate that a recorder is in use from that listening position.



the liquidation of the German Eighth Army was flashed out within six minutes and reached Washington five minutes before the Associated Press carried the news as urgent.

These are but a few of the achievements of the Monitoring Service of the British Broadcasting Corporation which, at the time of the German surrender, had developed into the largest and most efficient listening post in the world.

The location of this service was one of the most closely guarded secrets of the war. It was in the Oratory School for Boys at Caversham, Berkshire, that John Jarvis, a blind man with amazing hearing and memory supervised this activity.

From a few perspiring young men struggling rather on their own initia-

tive to keep a record of what the enemy was saying, the Monitoring Service grew in five years to a highly organized professional news and intelligence service comprising over six hundred employees and listening to every audible broadcast worth mentioning throughout the world. Before the German surrender it was listening to about one and a quarter million words a day in thirty-two languages. Some three hundred thousand words were daily transcribed into English, of which approximately one hundred thousand were published in a Daily Digest of World Broadcasts, and twenty-five to thirty thousand a day flashed as an urgent service on teleprinter to 19 War, Government, and BBC departments. In addition, the daily Monitoring Report, giving the main slants of world radio propaganda and news and a short daily report for the War Cabinet offices, were issued. Specialists produced a daily digest in German, French, and Italian.

The world *monitor* requires explanation. Before the war there was, by international agreement, a technical station at Brussels which checked on all wavelengths and warned broadcasting stations when they wandered too far off their allotted frequency. This machine was the *monitor*, Latin for advisor.

Listening in to other nations' broadcasts did actually start in Britain by the BBC as long ago as the Italo-Abyssinian campaign. But the application of the word monitor, derived from the Brussels machine, did not occur until



# New!

## Series 200

# A RELAY BY GUARDIAN with Interchangeable Coils

### BUILT IN TWO PARTS

A.C. Coil Assemblies available for 6 v., 12 v., 24 v., 115 v.  
D.C. Coil Assemblies available for 6 v., 12 v., 24 v., 32 v., 110 v.

★ Two basic parts—a coil assembly and a contact assembly—comprise this simple, yet versatile relay. The coil assembly consists of the coil and field piece. The contact assembly consists of switch blades, armature, return spring, and mounting bracket. The coil and contact assembly are easily aligned by two locator pins on the back end of the contact assembly which fit into two holes on the coil assembly. They are then rigidly held together with the two screws and lock washers. Assembly takes only a few seconds and requires no adjustment on factory built units.

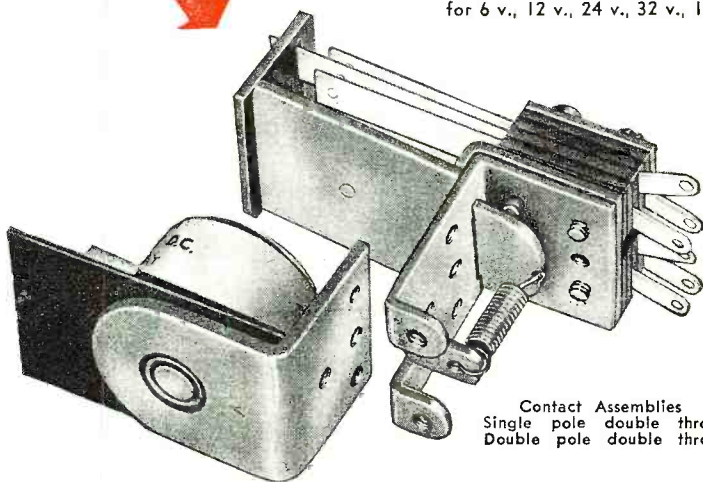

SERIES 200 RELAY

## On Sale at Your Nearest Jobber NOW!

See it today! . . . this amazing new relay with interchangeable coils. See how you can operate it on any of nine different a-c or d-c voltages—simply by changing the coil. Ideal for experimenters, inventors, engineers.

### TWO CONTACT ASSEMBLIES

The Series 200 is available with a single pole double throw, or a double pole double throw contact assembly. In addition, a set of Series 200 Contact Switch Parts, which you can buy separately, enables you to build dozens of other combinations. Instructions in each box.

### NINE COIL ASSEMBLIES

Four a-c coils and five d-c coils are available. Interchangeability of coils enables you to operate the Series 200 relay on one voltage or current and change it over to operate on another type simply by changing coils.



Your jobber has this sensational new relay on sale now. Ask him about it. Or write for descriptive bulletin.

# GUARDIAN ELECTRIC

1630-A W. WALNUT STREET CHICAGO 12, ILLINOIS  
A COMPLETE LINE OF RELAYS SERVING AMERICAN INDUSTRY



# FOR Easy LISTENING



## MURDOCK RADIO PHONES

MURDOCK Radio Phones are built by sound manufacturing methods to give service—traditionally outlasting ordinary radio phones by years of service.

No other listening experience is like hearing through the "Ears-of-a-Nation"—produced by MURDOCK. Thousands are now listening without strain or discomfort. They get the message right . . . the first time . . . all the time!

MURDOCK Radio Phones have been a FIRST for over 40 years with unusual features that mean effective, easy listening. Be sure to consult with MURDOCK for sturdy, solid-built HEAD PHONES!

Write for Catalog

### JOBBERS!

MURDOCK RADIO PHONES are now available to you in greater quantities. Write us for full information.

**WM. J. MURDOCK CO.**  
201 Carter St., Chelsea 50, Mass.

the time of Munich. The Monitoring Service of the BBC did not begin until the late summer of 1939.

The Hellschreiber, a German invention, does for radio what the tape machine does by land-lines. An elaborate

Hellschreiber organization was used by Goebbels for service and instructions to his network of newspapers and broadcasting units all over Germany and occupied Europe. There  
(Continued on page 141)

## RADIO-CONTROLLED TARGET AIRPLANE DEVELOPED BY ATSC

**T**HE restricted lid was lifted recently from one of the Army's most ingenious training devices, the radio-controlled, pilotless target airplane developed at Air Technical Service Command Headquarters at Wright Field, Ohio.

Able to fly at speeds ranging from 100 to 200 miles-per-hour and at altitudes up to 3000 feet, controlled by radio from the ground, the target airplane is the result of eight years of intensive research work by Lt. Col. Chester O. French, Jr., and his Control Equipment Branch, Equipment Laboratory staff.

Two models are now standard equipment for the Army Air Forces, the OQ-3 and OQ-14. They are used as targets for aerial gunnery practice by B-29 gunners and also for anti-aircraft practice by ground forces. The Navy is using the radio airplane target in its training program for automatic weapons target practice aboard combatant ships. Navy officers and enlisted personnel have been trained in the operation of the pilotless airplane.

The radio airplane target has recently found another use, that of a training aid for students of radar in tracking flying objects in the air for gunnery practice.

Manufactured by the *Radioplane Company*, Van Nuys, Calif., and *Globe Corporation Aircraft Division*, Joliet, Ill., the OQ-3 airplane target is a high-wing monoplane, 9 feet long, with a wing span of 12 feet, 3 inches. It weighs 100 pounds and is capable of flying 103 miles-an-hour. It is constructed of welded steel tubing covered with airplane cloth. The power plant is an 8 horsepower, 2-cylinder, 2-cycle gasoline engine.

The OQ-14, a later model, has a wing span of 11 feet, 6 inches and is powered with a 22 horsepower engine. This model will fly 140 miles-per-hour.

Take-off is accomplished by the use of a catapult, powered by compressed spring coils or rubber shock cord. After launching, the target is radio-controlled and is operated by elevator and rudder controls only. Landing is made by parachute, released either by the control operator or automatically as a result of damage from vital hits.

The elevator and rudder servo controls remain in effect after the engine is stopped and the parachute released, providing the radio has not been damaged, so that *dead-stick* landings can be made in the event the parachute attachments are shot away.

The basic system of radio control for the target involves the use of an ultra-high frequency carrier wave, modu-

lated by five different audio frequencies. A small control box attached to the transmitter by means of a flexible extension cable, equipped with a stick to simulate actual airplane control, is used to select the proper radio signals.

Four audio-frequency tones are used to control the target airplane in flight, one each for left, right, up, and down. A fifth frequency centers rudder and releases the parachute. Only one of these audio frequencies is used at a time. When one of the control frequencies is not in use, the fifth, or parachute frequency, is automatically switched on.

Installed in the plane is a radio receiver selector, which translates the radio waves and actuates, by electrical energy, the servo unit in the airplane. The servo unit provides the mechanical action to control the elevators and rudder. Operation has been so simplified that anyone without previous experience can learn to fly the target plane in 6 hours.

Use of the plane has provided a realistic target for student gunners because of its ability to simulate flight attitudes, dives, and evasive action.

The development of the radio-controlled pilotless plane started with an idea by Reginald Denny, stage and screen actor, who in the early 1930s built a radio controlled airplane model. Its possibilities became evident to the Army after a newspaper account of it appeared. In 1937, the Army Air Forces entered the picture and took over the project for development, assigning it to the old AAF Materiel Command.

The first experimental models had a 3 horsepower engine with counter-rotating props to counteract torque, square cross-section fuselage, and tricycle landing gear. The method of control included a telephone dial. Experiments, tests, and further development by ATSC finally eliminated the counter-rotating propellers, landing gear, and telephone dial control. Torque action was eliminated through design incorporating inherent stability. With the use of steel tubes for the framework, the landing gear became unnecessary as the rugged construction of the airplane absorbed the landing shock.

By 1942 the radio airplane target had been developed enough to go into production and student gunners began practicing on them. Experimentation with the planes is still being carried on at ATSC headquarters, Wright Field.



PLEASE PLACE YOUR ORDER WITH YOUR REGULAR RADIO PARTS JOBBER. IF YOUR LOCAL JOBBER CANNOT SUPPLY YOU, KINDLY WRITE FOR A LIST OF JOBBERS IN YOUR STATE WHO DO DISTRIBUTE OUR INSTRUMENTS OR SEND YOUR ORDER DIRECTLY TO US.



## The New Model CA-11 SIGNAL TRACER

Simple to operate . . . because signal intensity readings are indicated directly on the meter!

Essentially "Signal Tracing" means following the signal in a radio receiver and using the signal itself as a basis of measurement and as a means of locating the cause of trouble. In the CA-11 the Detector Probe is used to follow the signal from the antenna to the speaker — with relative signal intensity readings available on the scale of the meter which is calibrated to permit constant comparison of signal intensity as the probe is moved to follow the signal through the various stages.

### Features:

- ★ SIMPLE TO OPERATE — only 1 connecting cable — NO TUNING CONTROLS.
- ★ HIGHLY SENSITIVE — uses an improved Vacuum Tube Voltmeter circuit.
- ★ Tube and resistor-capacity network are built into the Detector Probe.
- ★ COMPLETELY PORTABLE — weighs 5 lbs. and measures 5" x 6" x 7".
- ★ Comparative Signal Intensity readings are indicated directly on the meter as the Detector Probe is moved to follow the Signal from Antenna to Speaker.
- ★ Provision is made for insertion of phones.

The Model CA-11 comes housed in a beautiful hand-rubbed wooden cabinet. Complete with Probe, test leads and instructions.....Net price

**\$18<sup>75</sup>**  
**18**

## The New Model 450 TUBE TESTER

### Specifications:

- Tests all tubes up to 117 Volts including 4, 5, 6, 7, 7L, Octals, Loctals, Bantam Junior, Peanut, Television, Magic Eye, Hearing Aid, Thyratrons, Single Ended, Floating Filament, Mercury Vapor Rectifiers, etc. Also Pilot Lights.
- Tests by the well-established emission method for tube quality, directly read on the scale of the meter.
- Tests shorts and leakages up to 3 Megohms in all tubes.
- Tests individual sections such as diodes, triodes, pentodes, etc., in multi-purpose tubes.
- New type line voltage adjuster.
- NOISE TEST: Tip jacks on front panel for plugging in either phones or external amplifier will detect microphonic tubes or noise due to faulty elements and loose internal connections.
- Works on 90 to 125 Volts 60 Cycles A.C.



**SPEEDY OPERATION** assured by newly designed rotary selector switch which replaces the usual snap, toggle, or lever action switches.

The model 450 comes complete with all operating instructions. Size 13"x12"x6". Net weight 8 lbs. **\$39<sup>50</sup>**  
Our Net Price.....

## The Model PB-100 VOLT-OHM-MILLIAMMETER

### Features:

- ★ Push Button Operation
- ★ Direct Reading
- ★ Housed in Portable Oak Cabinet
- ★ No External Source of Current Required

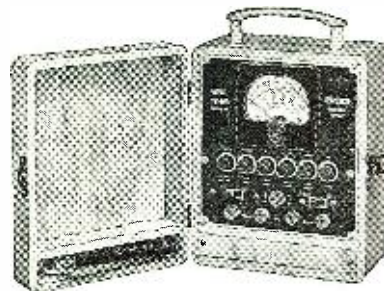

### Specifications:

6 D.C. VOLTAGE RANGES: 0 to 5/25/50/250/500/2500 Volts  
5 A.C. VOLTAGE RANGES: 0 to 10/50/100/500/1000 Volts  
5 OUTPUT METER RANGES: 0 to 10/50/100/500/1000 Volts  
3 D.C. CURRENT RANGES: 0 to 10/250 Ma. 0 to 2.5 Amp.  
3 RESISTANCE RANGES: 0 to 10,000/100,000 Ohms, 0-1 Meg.  
3 DECIBEL RANGES: -10 to +15; 0 to +35; +30 to +55.  
Model PB-100 comes housed in a hand-rubbed oak cabinet, self contained battery, test leads and instructions. Net price..... **\$28<sup>40</sup>**



# SUPERIOR INSTRUMENTS CO.

Dept. RN 227 FULTON ST., NEW YORK 7, N. Y.



# WHAT'S NEW IN RADIO

## CHARGICATOR

A newly developed Chargicator which indicates electrically the equivalent gravity of any lead-acid storage battery is now being manufactured by the *Hickok Electrical Instrument Company*.

This probe type *Hickok* Chargicator is designed to permit supersensitive

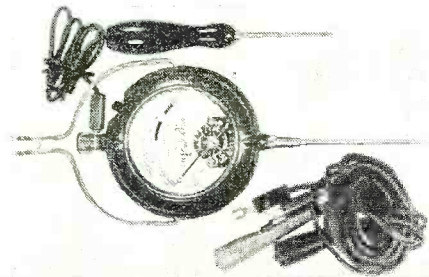

measurements whether permanently connected to the battery or used as a portable tester. It shows what charging rate to use, either for trickle charging or for an efficient, safe, high-rate charge, and indicates the percentage of charge and charging danger. Weak or defective cells may be readily and accurately spotted before actual failure occurs, and it may also be used in conjunction with a load test as a check against future failure.

High precision calibration on a big four-color scale, easy-to-read dial, eliminates guesswork. A size and type for every need is available and all models are sealed within molded acid-proof bakelite cases and are not affected by weather or temperature.

Details of this instrument may be obtained from *Hickok Electrical Instrument Company*, 10524 Dupont Avenue, Cleveland 8, Ohio.

## INSULATION TESTER

The *Weston Electrical Instrument Corporation* is now offering a new sensitive direct-reading insulation measuring device for applications where high testing potentials are not desired. This instrument provides a single

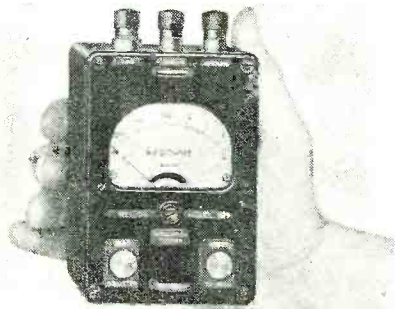

range for readings from .1 megohm to 10,000 megohms, with the 10,000 mark at 8 per cent of the scale length, providing good readability. The cir-

cuit has a test potential of less than 50 volts d.c. An electrical guard circuit is furnished for elimination of surface leakages when testing cables. The tester has wide use in the electrical and other industries, in electrical testing, for example, replacing expensive or specially built test stands, checking leakage between windings in transformers, cable resistance, leakage of low-voltage paper and mica condensers without damaging the dielectric, and many other uses. It is used for studying insulation characteristics in the plastic, paint, and other industries, for moisture absorption tests in leather and other fields, and conductivity testing by safety shoe manufacturers.

This 10,000-megohm insulation tester, known as Model 799, is only 5 3/8" by 3 1/4" by 4 7/8" in dimensions. It features a press-to-read switch, which automatically disconnects the battery circuit when not in use. The exposed metal parts have been thoroughly insulated for the operator's protection. Attachment to the lineman's belt or shoulder strap is permitted through ferrules in the panel.

Complete information on their new product will be supplied by the *Weston Electrical Instrument Corporation*, 617 Frelinghuysen Avenue, Newark 5, New Jersey.

## WATERPROOF SWITCH COVER

The *Waterproof Electric Company* has announced the release of its waterproof switch cover for general use on government and other high-priority equipment.

This device completely seals bat-handle type toggle switches against water and moisture. It is Navy-approved for overseas use under adverse marine and climatic conditions. No special tools are needed for installation, and the Neoprene boot is readily replaceable without removing nuts, screws, etc.

Further information will be sent on request to *Waterproof Electric Company*, 72 East Verdugo Avenue, Burbank, California.

## MIDGET VIBRATOR

The *Radiart* Midget Vibrator, VR-2, is now available for civilian applications. This vibrator is the smallest vibrator made and measures 2 1/8" high by 1 1/8" in diameter. It is one of the new radio developments of the war and was designed for operation from a small 6-volt storage battery in furnishing power to replace dry battery power in certain communications equipment.

Specifications of the VR-2 are as follows: vibrator frequency is 185 c.p.s., input voltage range is 4.5 volts to 7.5

volts with a normal voltage of 6.0 and an input current of 1.5 amps max. at 6.0 v. The output voltage is 200 v.d.c. max. Maximum potential difference between primary reed and secondary reed is 25 volts.

Manufacturers desiring additional information may write to *Radiart Corporation* for blueprints and engineering co-operation.

## MOBILE V.H.F. STATION

*Aireon Manufacturing Corporation* has announced its new very-high-frequency station combination for emergency and mobile installations. This transmitter-receiver combination operates in the 30-42 megacycle region and is designed to be used for a fixed or mobile installation merely by interchanging a 6-volt power supply and a conventional 110-volt supply.

Entire control of transmitter and receiver is gained by a push-to-talk button on the single button microphone. This mobile radio station is built around a 60-watt crystal-controlled transmitter using phase type modulation. The type 807 power amplifiers feed a 1/4-wave whip antenna for mobile installations, 1/2-wave coaxial an-

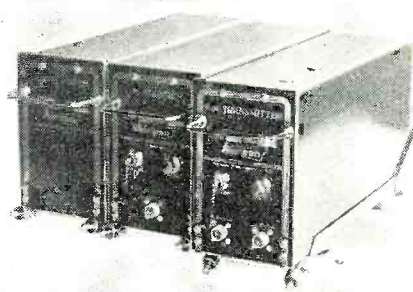

tenna for central station. Modulation is type A3 (special) with a frequency deviation of 12 kilocycles, and special relay system permits either local or remote operation of any installation.

The receiver (560) is a thirteen-tube double superheterodyne type. The unit is entirely permeability-tuned and both i.f. stages are crystal-controlled. Sensitivity is 1/2 microvolt, and signal to noise ratio is excellent with 1 microvolt input. Audio power output of the receiver is 1 1/2 watts.

Further details will be furnished upon request to *Aireon Manufacturing Corporation*, Kansas City, Kansas.

## SPEED RELAY

A hermetically sealed sensitive relay capable of speeds up to 1000 operations per second has been announced by *Stevens-Arnold Co., Inc.*

The basic design of the moving elements is quite different from conventional relay practice, making possible the ultra high speed and assuring great

**RADIO NEWS**



**OUT IN  
DECEMBER**

**IT'S EASY TO READ  
AND UNDERSTAND**

**IT'S "THIRD  
DIMENSIONAL"**

**IT'S FUNDAMENTAL**

**IT'S TIMELY**

**IT'S A BARGAIN**

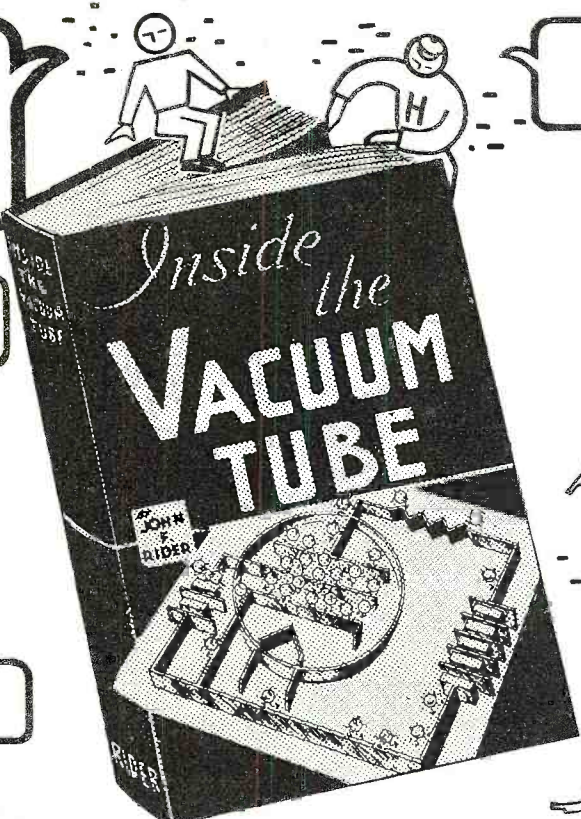

**424 Pages  
\$4.50**

**T**his is not just another book on the vacuum tube, but a typical Rider Book, offering a new approach to the subject—presented with a technique that makes its message clear and easy to understand. Here is a solid, elementary concept of the theory and operation of the basic types of vacuum tubes upon which can be built more advanced knowledge.

After explaining the electron theory, the text presents a discussion on electrostatic fields, on the theory that the reader's understanding of the distribution and behavior of the fields within a tube will give him a better picture of why amplification is accomplished within a tube and how the grids and plates are interrelated.

To give a clear physical picture of its subject, the book

employs novel physical devices. For example, certain diagrams and graphs are repeated, to reduce to a minimum the bother of turning pages back and forth to read text and drawings. Another innovation is the use of anaglyphs, "three-dimensional" pictures of phenomena heretofore seen only in two dimensions. Viewed through glasses supplied with the book, they are invaluable aids toward the rapid understanding of the text.

Although this is an elementary book on a fundamental subject, therefore a goldmine for the student; developments in radio and the new fields of television and microwaves make it a must for the libraries of servicemen, amateurs and engineers. Place your order today.

**OTHER RIDER BOOKS**

- RIDER MANUALS (14 VOLUMES)**
- Volumes XIV to VII . . . \$12.50 each volume
- Volumes VI to III . . . 9.50 each volume
- Abridged Manuals I to V**  
(1 volume) . . . . . \$15.00
- Automatic Record Changers and Recorders** . . . . . 7.50
- The Cathode Ray Tube at Work**  
Accepted authority on subject . . . . 4.00

- Frequency Modulation**  
Gives principles of FM radio . . . . \$2.00
- Servicing by Signal Tracing**  
Basic Method of radio servicing . . . 4.00
- The Meter at Work**  
An elementary text on meters . . . . 2.00
- The Oscillator at Work**  
How to use, test and repair . . . . . 2.50
- Vacuum Tube Voltmeters**  
Both theory and practice . . . . . 2.50

- Automatic Frequency Control Systems**  
—also automatic tuning systems . . . \$1.75
- A-C Calculation Charts**  
Two to five times as fast as slide rule . 7.50
- Hour-A-Day-with-Rider Series—**
- On "Alternating Currents in Radio Receivers"
- On "Resonance & Alignment"
- On "Automatic Volume Control"
- On "D-C Voltage Distribution" . . . 1.25 each

**JOHN F. RIDER PUBLISHER, INC. 404 FOURTH AVE., N. Y. 16, N. Y.**  
Export Division: Rocke-International Electric Corp. 13 E. 40th Street, New York Cable: ARLAB

*—and Don't Forget* **RIDER MANUALS** *are Now Complete in 14 Volumes*

**They Provide Schematics and Essential Servicing Data on American Made Radio Receivers.**



# The Answer TO YOUR INSTRUMENT PROBLEMS

## Burlington

### PANEL INSTRUMENTS

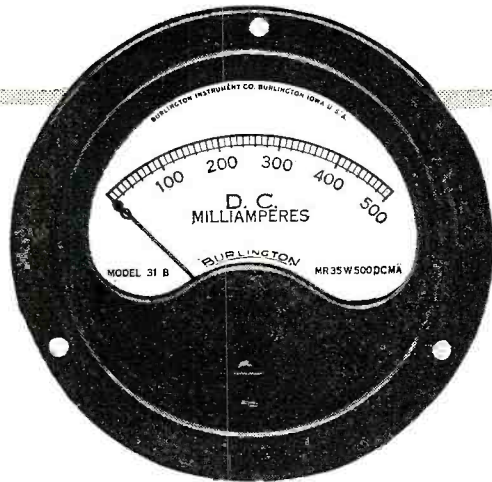

Burlington Panel Instruments are designed and built to give dependable service with guaranteed accuracy. They are available in a complete line of AC or DC Ammeters, Voltmeters, Milliammeters, and Microammeters. The wide selection of sizes and case styles offer instruments that are ideal for your particular application.

Write today for full details — our engineers will recommend the precision Burlington Instruments required to solve your instrument problems.

**BURLINGTON INSTRUMENT CO.**

901 Fourth St., BURLINGTON, IOWA

**B**

PANEL INSTRUMENTS • VOLTAGE REGULATORS • AUTOMATIC SYNCHRONIZERS • FREQUENCY REGULATORS

reliability if operated in the usual speed ranges. A cut-through section in the illustration shows the glass envelope which surrounds all moving parts and protects them from moisture, dust, or corrosive fumes.

Sensitivities down to ½ milliwatt

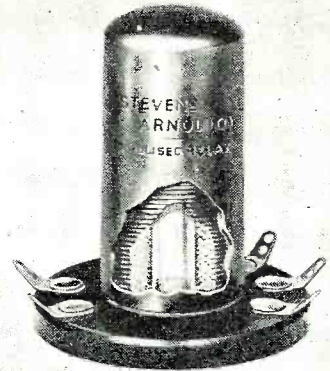

are possible with this new type of construction and ratings up to 5 amperes can be obtained. Closing time can be less than one millisecond. The outside dimensions of the 115-volt a.c. 1-ampere rating are 3" high and 1½" base diameter.

Full details of this relay are obtainable from *Stevens-Arnold Co. Inc.*, 22 Elkins Street, South Boston, Massachusetts.

#### VIDEO AMPLIFIER

*United Cinephone Corporation* is now offering a new video amplifier designed primarily for use in amplifying complex waves to be viewed on an oscilloscope. This amplifier may also be used in laboratory work as an audio amplifier for tracing and measuring small r.f. voltages and many similar applications.

The frequency response is flat within 1.5 db. of the 10-kc. response from 15 cycles to 4 megacycles, and 3 db. from 10 cycles to 4.5 megacycles. The phase shift is reduced to a minimum to provide satisfactory reproduction of pulses on the order of one microsecond,



and square waves at repetition rates as low as 100 a second.

The gain is approximately 1000 when direct input is used. Input is normally through a probe, furnished with the equipment, having an attenuation of



**PROTECT THE CONTINUITY**  
of electrical currents

with  
**AMPHENOL**  
CONNECTORS

As the aviation industry again swings into peacetime production, Amphenol is ready to offer practical aid in many forms. Amphenol components helped to fight a winning war . . . and now Amphenol engineers with their "know-how"—deepened and strengthened by wartime experience—are cooperating in creating peacetime applications for aviation communications, electrical circuits and electronic controls. Amphenol connectors, cable assemblies and other parts provide positive electrical contacts within all types of equipment. For detailed technical data on Amphenol products—send for Condensed Catalog No. 72.

AMERICAN PHENOLIC CORPORATION  
CHICAGO 50, ILLINOIS  
In Canada • Amphenol Limited • Toronto



U.H.F. Cables and  
January, 1946

• Connectors • (A-N, U.H.F., British) • Conduit • Cable Assemblies • Radio Parts • Plastics for Industry



# LAKE'S

## RADIO CABINETS & PARTS

for  
**Your Every Need!**

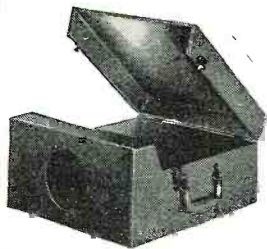

Portable Phonograph case in brown leatherette covering. Inside dimensions 17½" long, 13" wide, 7½" high. Has blank motor board and opening for speaker. As illustrated at left, specially priced at.....

**\$7.95**

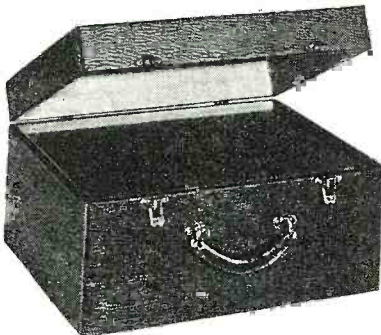

Portable Phonograph case, of sturdy durable plywood, in handsome brown leatherette finish. Inside dimensions 16½" long, 14" wide, 9½" high. Has blank motor board. As illustrated above, specially priced at.....

**\$6.95**

Also blank table cabinets of walnut veneer in the following sizes, with speaker opening on left front side: (\*Note: \*7 has center speaker grill.)

#1	8½"	L x 5½"	H x 4"	D \$1.95
#2	10½"	L x 6½"	H x 5"	D \$2.75
#3	13½"	L x 7½"	H x 6¼"	D \$3.25
#7*	10¾"	L x 7"	H x 5½"	D \$2.50
#8	17"	L x 9"	H x 9¾"	D \$4.50
#9	21"	L x 9¼"	H x 10½"	D \$5.50

\*Speaker opening in center of front side. Cabinets available in ivory color and Swedish Modern. Write for prices.

### POWER TRANSFORMERS

4, 5 or 6 Tube—6.3V at 2 amp. **\$1.49**  
50 Mill Power Transformer....

7, 8, or 9 Tube—6.3V at 3 amp. **\$1.89**  
70 Mill Power Transformer....

### SOUND ACCESSORIES

Complete line of amplifiers, microphones, speakers, and sound accessories.

All types of radio cabinets and parts are available at Lake's Lower prices. A large stock is listed in our catalog.



**SERVICEMEN—RETAILERS**  
Join our customer list today.

Dept. A

Write for our NEW, 12 page, illustrated, elaborate catalog!  
Order from Lake!  
You'll make no mistake!

## Lake Radio Sales Co.

615 W. Randolph Street

Chicago 6, Ill.

10 times. The amplifier direct input (without probe) is approximately 2.2 megohms of resistance in parallel with 40  $\mu\text{fd}$ . This compares with 1.1 megohm resistance in parallel with approximately 18  $\mu\text{fd}$ . when the probe is used. The output voltage can be adjusted from zero to 50 volts r.m.s. with sine wave signals. The ripple output is less than .5 volt for all operating conditions and all positions of gain control.

(Continued on page 130)

### Sweep Oscillators

(Continued from page 53)

and  $R_3$ , for capacitor  $C_1$  may charge only over the linear portion of its charging cycle. Thus, the linear rise of the sawtooth is generated when tube two is non-conducting and the rapid retrace occurs when tube two conducts and removes the charge from capacitor  $C_1$ . The frequency of the sweep can be varied over a limited range with resistor  $R_4$ , as it controls the rate at which capacitor  $C_2$  discharges and, therefore, the amount of time required for grid two to rise to the conduction level. Thus, if  $R_4$  is decreased in value, the capacitor discharges faster and the grid reaches the conduction level earlier, generating a higher-frequency sawtooth.

Synchronization is accomplished by applying a negative pulse to the grid of tube one, which appears as a positive pulse on grid two. When this sync pulse occurs at a time when tube two grid voltage is nearing the tube conduction bias, it immediately causes tube two to conduct, initiating the retrace interval each time a sync pulse hits the grid.

The amplitude of the sawtooth is set by resistor  $R_2$  in the plate circuit. It determines to what amplitude  $C_1$  charges during the grid circuit discharge interval.

### Blocking Oscillator

The blocking-tube oscillator is another type of sawtooth generator often used to generate the television sweep. In this circuit, Fig. 5, in-phase voltage is fed back to the grid by transformer  $T_1$ . The blocking tube oscillator is widely used to generate the low-frequency vertical sweep. When used as a horizontal oscillator, the transformer must be carefully designed to pass the very high horizontal frequency and must have no self-resonant condition at this frequency.

To study the sequence of operation, let us first assume that the grid has gone slightly positive. A positive swinging grid causes the plate current to increase and plate voltage to decrease. Negative voltage across the transformer primary is transferred to the secondary with the proper polarity to reinforce the original positive swing of the grid. Thus there is a feedback cycle which rapidly drives the grid sharply positive. The grid continues to swing positive until it reaches a lev-

el where a further increase in grid voltage causes no further increase in plate current (saturation point or, more often, a limiting point where the instantaneous grid current drawn through resistor  $R_1$  prevents any further increase in grid voltage). At the instant there is no change in plate current, there is no variation in plate voltage across the transformer primary. Consequently, the lack of feedback for an instant, causes the grid to start negative, plate current to decrease, and plate voltage to increase. This new plate voltage variation is transformer-coupled to the grid as a further decrease in grid voltage and our grid is driven rapidly negative by feedback of opposite polarity.

The grid is driven well beyond cut-off by the large plate voltage swing and collapsing field surrounding the transformer. A large negative charge remains on capacitor  $C_1$ , which holds the grid beyond cut-off until the charge leaks off to ground through resistor  $R_4$ . The time required for the charge to leak off and, consequently, the frequency of the sawtooth, is again dependent on the time constant of  $R_4$  and  $C_1$ .

Typical waveforms of the blocking oscillator are shown in Fig. 6. The time from  $a$  to  $b$  on the grid voltage

Fig. 6. Typical waveforms of the blocking-type oscillator.

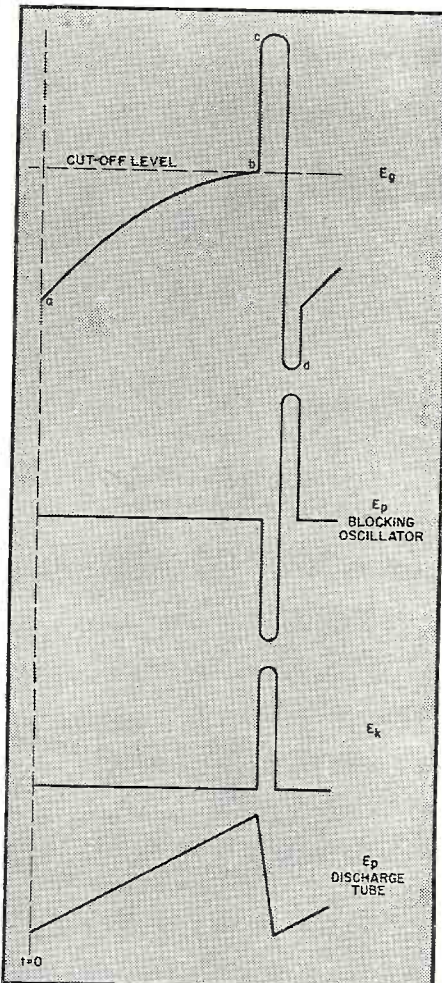





*Which for You—*  
**SCREWDRIVER  
 or SLIDE RULE ?**

**Face the Facts . . .**

**You Must Train Now to Step Ahead  
 of Competition Into a Good-Paying Job in Radio-Electronics**

**—or be left behind because you lack  
 the understanding of new electronic techniques**

CREI home-study courses are for professional radio-men only and this CREI message is for those who are not afraid to face the facts! The bars are down on radio-electronics progress! You are facing a completely new era in the radio-electronics world. The war-restricted curtains of secrecy have been pulled aside, revealing each day momentous, revolutionary applications of new radio-electronic principles and theories, and their complicated circuits, equipment, individual parts, etc.

No matter what your past radio-electronics experience has been, no matter what your training, you must start anew to add to your store of radio-electronics knowledge. You must keep pace with the new developments and ahead of competition if you expect to get ahead in this

new world of radio-electronics—or even maintain your present position in the field.

How much do you know about U.H.F. Circuits, Cavity Resonators, Wave Guides, Klystrons, Magnetrons and other tubes? All these revolve largely around U.H.F. applications. And here is where CREI training can help you. In our proved home study course, you learn not only how . . . but why!

Let CREI train you now to trade that "screwdriver" for a slide rule. Do something about increasing your technical ability and advance to the better-paying radio jobs that offer security and opportunity. The facts are in the free booklet. Send for it today.

**Servicemen—  
 Discharged Veterans**

**CREI Residence Training  
 Available Under  
 Provisions of "G.I." Bill**

CREI now offers Residence School courses in Radio-Electronics Engineering, Broadcast & Television Engineering and Broadcast & Television Servicing under the Serviceman's Readjustment Act of 1944 ("G.I." Bills) Classes now in session. Enter at any time. Write for details.

**WRITE TODAY FOR FREE 36-PAGE BOOKLET**

**"Your Opportunity in the New World of Electronics"**

TELL US ALL ABOUT YOURSELF, so that we can intelligently plan a course best suited to your needs. If you have had professional or amateur radio experience—let us prove to you that we have something you need to qualify for a better radio job. To help us intelligently answer your inquiry—PLEASE STATE BRIEFLY YOUR BACKGROUND OF EXPERIENCE, EDUCATION AND PRESENT POSITION.



**CAPITOL RADIO Engineering Institute**

HOME STUDY COURSES IN PRACTICAL RADIO-ELECTRONICS  
 ENGINEERING FOR PROFESSIONAL SELF-IMPROVEMENT

**Dept. RN-1, 3224—16th Street, N. W., Washington 10, D. C.**

Contractors to U. S. Navy—U. S. Coast Guard—Canadian Broadcasting Corp.  
 Producers of Well-trained Technical Radiomen for Industry.

Member: NATIONAL COUNCIL OF TECHNICAL SCHOOLS



Have You had the  
Chassis Touching  
**JITTERS**  
Lately?  
Here's how to speed  
and ease Service



115 V.  70-140 V.

**Big, husky 1/2 K.W.**  
**ADJUST-A-VOLT**  
*isolation transformer*

**This basic service tool:**

- keeps AC-DC chassis neutral to ground.
- keeps AC-DC chassis neutral to grounded test equipment.
- will lower voltage to check intermittent oscillators.
- raises voltage to "pop" out stubborn intermittent parts.
- regulates voltage to service bench.
- boosts line voltage to portable P.A. systems.
- may be used as a speed control, or,
- an industrial voltage controller.

**\$17.50** each, net f.o.b.,  
Dayton, Ohio

TEAR OUT AND MAIL TO

**SREPCO**

STANDARD RADIO & ELECTRONIC PRODUCTS CO.  
135 EAST SECOND STREET, DAYTON 2, OHIO

Please ship at once \_\_\_\_\_ Adjust-A-Volt transformers

Name \_\_\_\_\_

Address \_\_\_\_\_

City \_\_\_\_\_ State \_\_\_\_\_

waveform represents the discharge interval of the grid circuit resistor-capacitor combination. When it has discharged to point *b*, the tube begins to conduct, originating the feedback cycle which drives the grid rapidly positive to point *c*. The flow of plate current decreases the plate voltage and increases the cathode voltage as shown in the figure. At point *c* the feedback reverses and the grid is driven far negative to point *d*. It should be noted that there is no further decrease in cathode voltage below the cut-off level. However, the plate voltage continues to go farther positive even after plate current has ceased. This rise in plate voltage is caused by the collapsing transformer fields, which contribute to the task of driving the grid beyond cut-off.

Here again is a circuit in which the tube conducts for a short interval and then remains idle for a longer period, as shown most clearly by the cathode waveform. Now, if there is a resistor-capacitor combination in the plate circuit, such as  $R_1$  and  $C_1$  in Fig. 5, the capacitor charges when the tube is cut off and discharges during the conduction period. Although this method is occasionally used, more often a discharge tube follows the blocking oscillator to generate a more linear sawtooth. Such a stage, Fig. 5, is fed directly off the grid of the blocking oscillator. The discharge tube has a plate circuit combination which has a long time constant that permits the capacitor to charge over only the very linear portion of the charging cycle. The grid of the discharge tube is biased by the grid waveform of the blocking oscillator and, consequently, is at cut-off during most of the cycle. However, when the grid goes sharply

positive, the discharge tube also conducts, discharging capacitor  $C_2$ . When it is non-conducting, capacitor  $C_2$  charges very slowly through  $R_2$  and  $R_3$ , for its time constant is longer than that of  $R_1$  and  $C_1$ . It is apparent that resistor  $R_1$  and capacitor  $C_1$  control the frequency of the sawtooth, while capacitor  $C_2$  and resistors  $R_2$  and  $R_3$  control the sawtooth linearity and amplitude.

The blocking-tube oscillator can be synchronized by a positive sync pulse applied to the grid or a negative to the cathode. In Fig. 7A, the grid waveform of the blocking oscillator free-running is shown. Now, if a sync pulse is applied to the control grid at point 1, just before the control grid voltage normally reaches the conduction point, the sync pulse immediately drives the grid into conduction just ahead of the normal free-running time, Fig. 7C. This condition, which causes each cycle of the sawtooth to be synchronized, exists as long as the sync pulses occur at a frequency slightly greater than the free-running frequency of the oscillator. Therefore, the new frequency of the sawtooth is of the same frequency as the sync pulses, but slightly greater than the free-running frequency of the oscillator. If the frequency of the sync pulses is lower than the free-running frequency, not every sawtooth is synchronized, because on some cycles the sync pulse occurs some time after the grid has reached the conduction point.

Next month's installment treats the removal of the sync pulse from the composite signal and the separation of the vertical and horizontal pulses. The necessity for equalizing pulses will also be discussed.

*(To be continued)*

Fig. 7. The synchronization of the blocking-type oscillator.

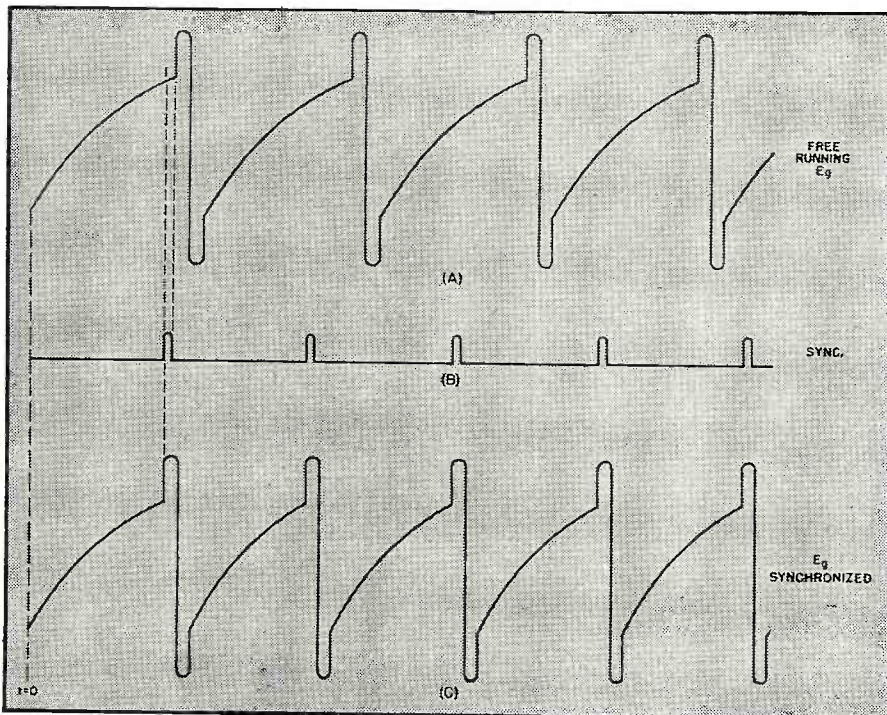



# TALK IS QUICK!

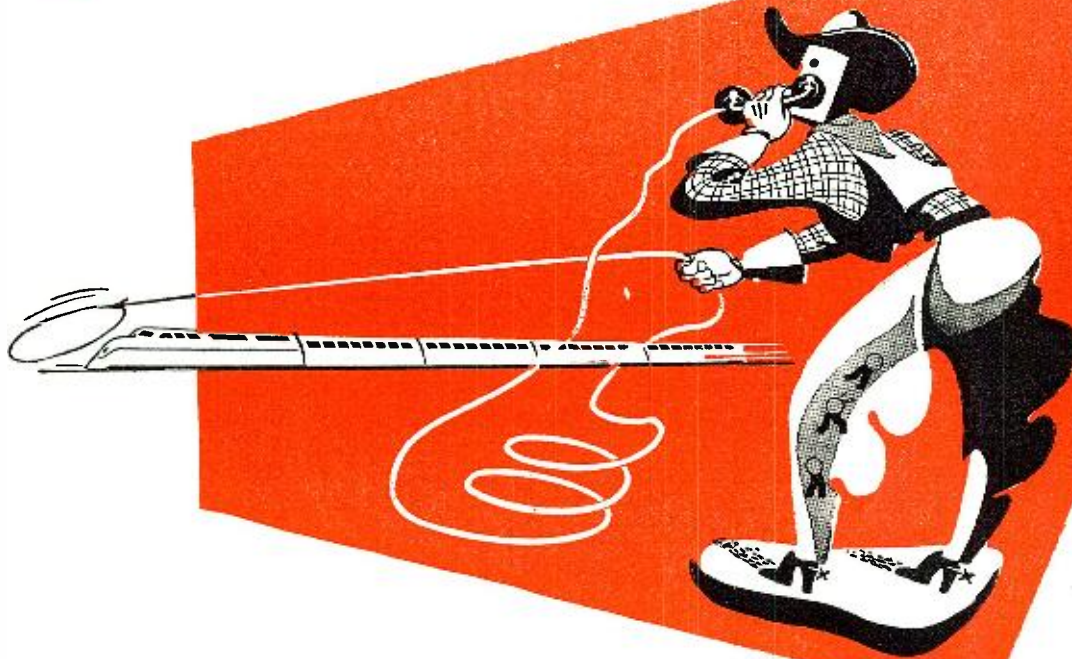

Pick up a 'phone and talk—to an airplane; a speeding train; an inter-city bus; a boat at sea.

Aireon's radio 'phones make this as simple, sure and easy as using a conventional telephone.

Aireon radio equipment for airlines is used by twenty domestic, four foreign companies; Aireon railroad radio, introduced under war-time restrictions, is *already in use* by four leading railroads. Aireon truck, taxi and bus communications equipment has been proved in service on the trucks of one of the nation's largest fleet operators. It's now in production. Aireon marine equipment will be available soon.

On the crowded highways and skyways of the future, radio 'phone communication will keep traffic moving under quick, efficient control.

**Aireon** MANUFACTURING CORPORATION

**Radio and Electronics • Engineered Power Controls**

NEW YORK • GREENWICH • CHICAGO • KANSAS CITY • OKLAHOMA CITY • BURBANK • SAN FRANCISCO  
January, 1946

75



# A Simple Remote TUNING DEVICE for Receivers

By CAPT. E. L. HANNUM, JR.

Development Officer Hq., AACCS, AAF

LOCAL man-made interference has always presented a major problem at practically all receiving positions or terminals of communications systems. The types of interference may vary with the kind of communications facilities under consideration, but the results, in all cases, are the same—impaired service due to poor reception.

There are several ways of improving the general situation—that is, by attempting to reduce the interference, by erecting the receiving antennas in a relatively noise-free location, or by removing both the receiver and the antenna to a suitable spot well removed from the operating position or source of noise. The first method is highly desirable, as interference should always be kept to an absolute minimum in any installation, if good reception is to be expected. However, there is a practical limit to which this elimination of interference can be carried. The problem is especially evident in airways communications, as airport control towers are invariably located on the flight line in close proximity to hangars and repair shops where arc-welding equipment, generators, radio test equipment, and other sources of interference are necessarily prevalent and extremely difficult to suppress. Obviously, the solution lies in removing the receiving antennas

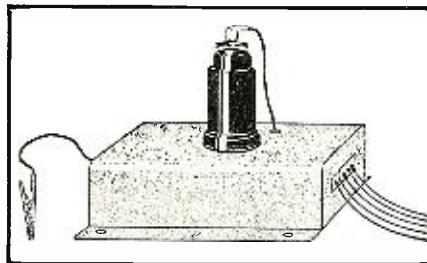

Fig. 1. Reactance to tuning unit.

from the immediate vicinity of the interference to a more advantageous location. In order to realize the full benefits of such a move, however, the receiver should also be removed and installed near the antenna, with the audio output transmitted by wire to the operating position, as distances in the order of several miles may be required between the antenna location and the operating position.

It is considerably less expensive and more practicable to transmit audio frequencies over a 600 ohm telephone line than it would be to construct a radio frequency transmission line and amplifiers to connect an antenna and a receiver over such distances. Hence, the ideal installation incorporates an isolated receiver and antenna, with a low impedance line feeding the receiver audio output to a loudspeaker

at the operating position. Such an installation should also appeal to the radio amateur or experimenter who finds his operating position in a location too noisy to permit good reception. Removing the receiver, however, presents the problem of remotely tuning the receiver from the operating position. The tuning device to be described should appeal to amateur, as well as commercial, installations because of its low-cost and simplicity of construction.

In aircraft or point-to-point communications, little or no need exists for changing dial settings to tune the receiver to a new frequency, as separate receivers are employed to cover the various operating frequencies. However, signals from aircraft transmitters which are slightly off frequency are occasionally encountered or a strong local signal may be heterodyning a weaker one, in which case it is imperative that the operator be able to vary the receiver tuning a few kilocycles above or below the operating frequency. With the receivers installed several miles from the operator's position, it becomes necessary to utilize a remote tuning device capable of accomplishing this desired frequency change from a distance. The reactance tube tuning unit to be described provides a shift of 10 kilocycles either side of the signal in the 100 to 400 kilocycle range, 200 kilocycles in the high frequency (7 to 18 mc.) range, and proportionate degrees of shift in the intermediate ranges. This limited range of tuning is entirely adequate for the types of installations previously described. However, simple changes of circuit component values will permit greater frequency variations if desired.

In order to minimize the number of lines necessary to connect the receiver and the operating position, the remote tuning system was designed to operate over the same lines that carry the receiver audio output. The reactance tube tuning unit itself was constructed on a small chassis (3½ x 2¼ x 1½ inches) and mounted directly on the main tuning condenser shield of the receiver. The tuning device was used with super-pro receivers, but worked equally well with other conventional superheterodynes. In operation, the reactance tube unit varies the receiver tuning by varying the frequency of the receiver's h.f. oscillator. It should be considered, however, that in varying the h.f. oscillator frequency in this manner, a new intermediate frequency is produced. Thus, in a receiver in which the i.f. transformers are sharply tuned, changing the h.f. oscillator frequency over too great a range may result in some loss of gain and reduced selectivity. Using the circuit values indicated, no such undesirable effects were noted.

The remote tuner operates on a principle somewhat similar to that employed by a reactance tube modulator for frequency modulation of a radio frequency oscillator, except that

Fig. 2. Circuit diagram and parts list for the one-tube remote tuning device.

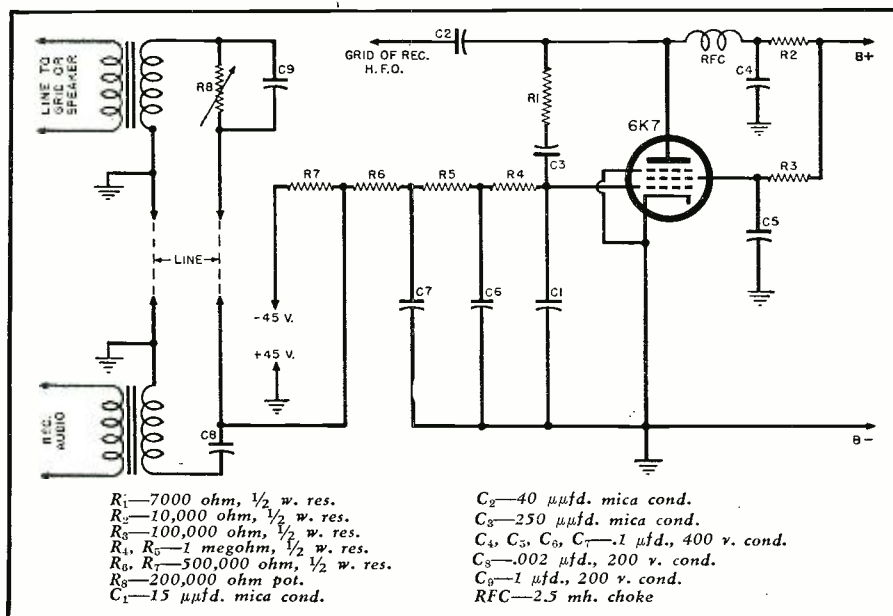



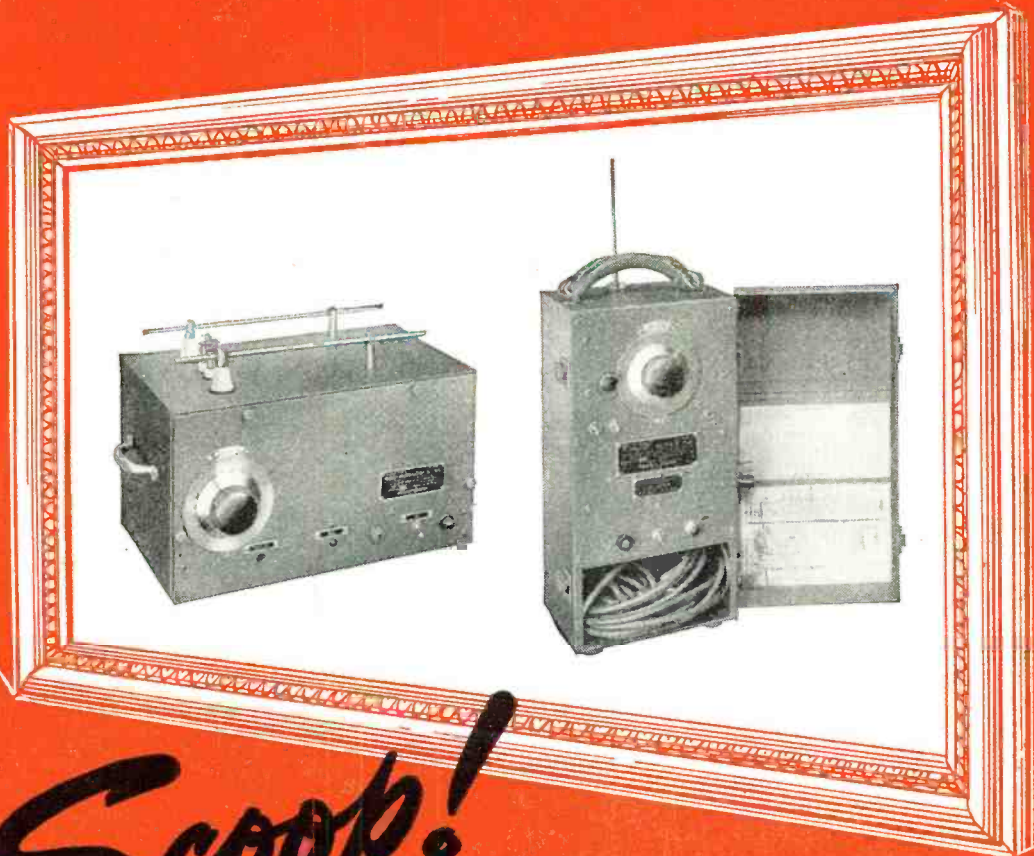

*Scoop!*

**Left: Radio Modulator BC-423.** High frequency signal generator operating from 195 to 205 mc., modulated at approximately 5000 cycles. Ruggedly built in steel case. Designed so that it can be re-adapted to many applications. Can be used as high frequency receiver, transceiver or frequency meter. Good for lab demonstrations requiring low power, ultra high frequency generator. Can be converted to 2½ or 1¼ meter receiver.

**Right: Frequency Meter BC-438.** Ultra-high frequency signal generator operating from 195 to 205 mc. with crystal calibration. Aluminum chassis in steel case. Removable nickel plated 19" telescopic antenna. Use as high frequency receiver or transmitter. Can be converted to cover any frequency range. Takes dry batteries for portable use. Precision tuning control make it ideal for "on the nose" ECO transmitter control unit.

## hallicrafters RADIO

THE HALLICTRAFTERS CO., AGENT FOR RFC UNDER CONTRACT SIA-3-24  
MANUFACTURERS OF RADIO AND ELECTRONIC EQUIPMENT

THESE VALUABLE ITEMS *Available Now*  
or very soon. Write, wire or phone for further information • head phones • test equipment • component parts • marine transmitters and receivers • code practice equipment • sound detecting equipment • vehicular operation police and command sets • radio beacons and airborne landing equipment.

**CLIP THIS COUPON NOW**

RFC DEPARTMENT 512, HALLICTRAFTERS  
5025 West 65th Street • Chicago 38, Illinois

Send further details on merchandise described above

Send listings of other available items

Especially interested in \_\_\_\_\_

STATE \_\_\_\_\_

NAME \_\_\_\_\_

CITY \_\_\_\_\_ ZONE \_\_\_\_\_

ADDRESS \_\_\_\_\_





**MAKE** your transformer replacements *more* profitable by specifying STANCOR Uni-dapt units. More adaptable because over 80% of all radio transformers now in use are replaceable with a standard Uni-dapt item.

It's this adaptability that makes STANCOR design complete, fulfilling the exact needs of radio serviceman, amateur, and electronic engineer in an economical manner.

For transformer replacements think first of STANCOR.

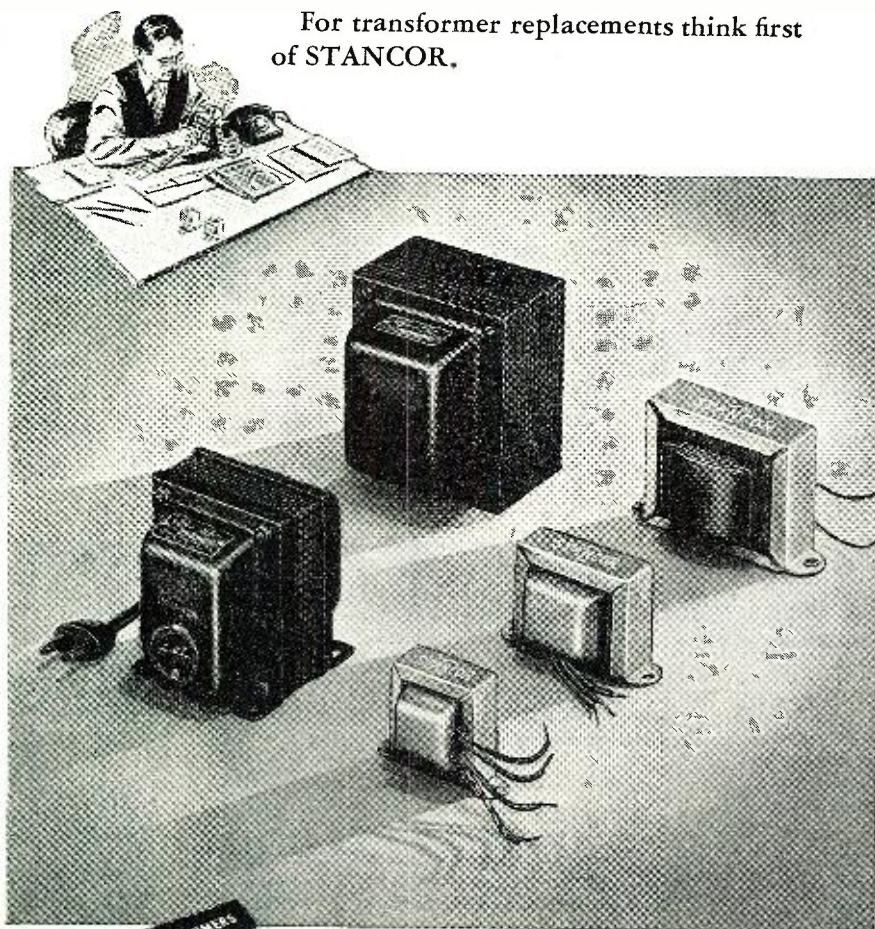

# STANCOR

STANDARD TRANSFORMER CORPORATION  
1500 NORTH HALSTED ST., CHICAGO 22, ILLINOIS

in this case the grid bias of the reactance tube is varied between two limits by a manual control in order to vary the amplitude of the reactive plate current, instead of introducing an audio frequency voltage on one of the control elements of the tube, as in the usual applications of circuits of this type. The manual control is a 200,000 ohm potentiometer inserted in the control lines at the receiving position and serves to vary the negative bias supply. A 45 volt battery or other external source of bias may be substituted at either the operating position or the receiver in case the device is used with receivers which do not incorporate a separate negative bias supply. However, in the super-pro, minus 50 volts is available at terminal number 7, and this voltage provides an ample swing of reactance tube grid bias. The output of the tuning device is connected through a small condenser to the grid cap of the receiver high-frequency oscillator, an arrangement which permits the lagging plate current of the reactance tube to be drawn through the oscillator tank, thereby effecting a change in oscillator frequency.

The theory of operation (Fig. 2) is as follows. When  $R_1$  is made large as compared with reactance of  $C_1$ , the r.f. current through  $R_1$  is practically in phase with the r.f. voltage in the oscillator tank. However, as in any resistance-capacity circuit, the voltage across  $C_1$  lags the current through  $R_1$  by 90 degrees. The current in the plate circuit of the reactance tube will be in phase with the grid voltage (the voltage across  $C_1$ ), and consequently will lag 90° behind the current through  $C_1$ . As this current is practically in phase with the h.f. oscillator tank voltage, the reactance tube plate current can be considered as lagging 90° behind the oscillator tank voltage and, when drawn through the oscillator tank, produces the same effect as though an inductance were connected across the tank (the current in an inductance lags the voltage by 90°). Hence, the frequency of the oscillator changes in proportion to the lagging plate current of the reactance tube, as determined by the grid bias on this tube.

If, however, the values of circuit components  $C_1$  and  $R_1$  are changed so that the reactance of  $C_1$  becomes large compared to the resistance of  $R_1$ , the reactance tube plate current will lead the oscillator tank voltage, resulting in a capacitive rather than an inductive reactance. The value of this applied reactance, whether inductive or capacitive, will be inversely proportional to the transconductance of the reactance tube. As the transconductance of the tube depends upon the grid bias, the effective reactance (and consequently, the oscillator frequency) can be changed by varying the grid bias.

A triple grid tube of the variable mu variety such as the 6K7 or the newer 9003 can be used as the reac-



# RADIART

## 1946 "DELUXE" AERIALS

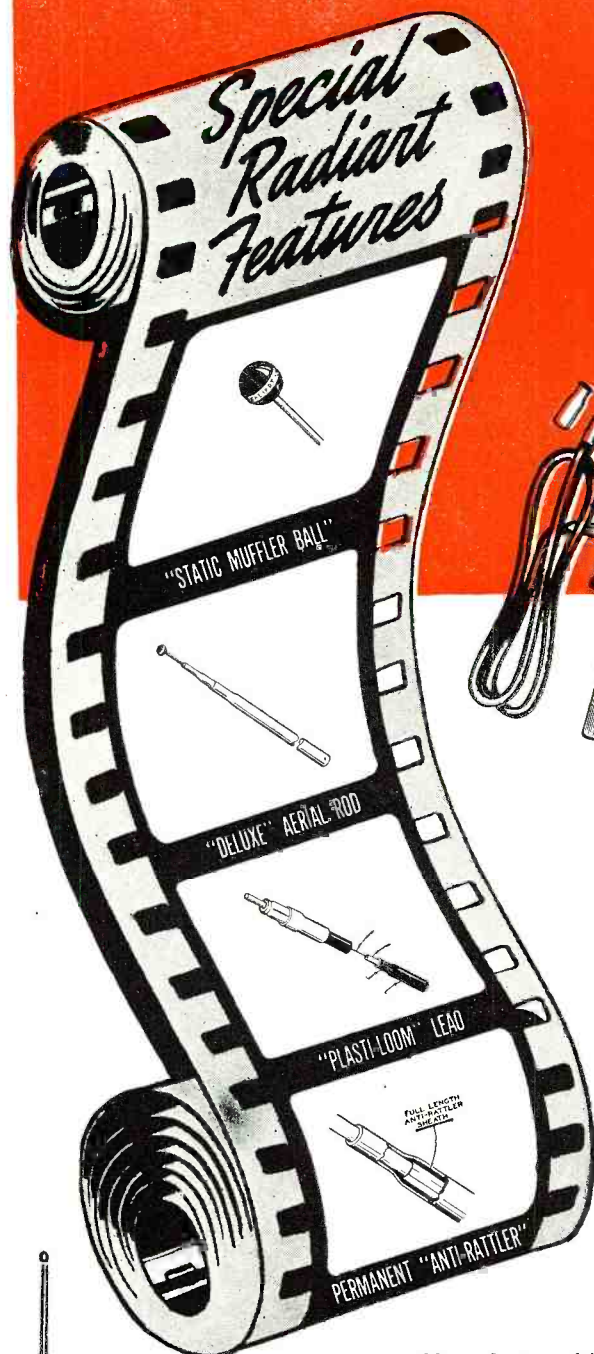

### AGAIN . . . RADIART SETS THE STANDARD!

With new features — highest quality materials — and super values, RADIART AERIALS are the Sensation of 1946.

The "Plasti-Loom" Lead (long enough for all installations) and Antimonial Admiralty Brass are two outstanding Radiart features. They make RADIARTS greater values than ever before.

Also, every RADIART AERIAL is complete — no extras to buy — another reason why RADIART is the line to sell in 1946.

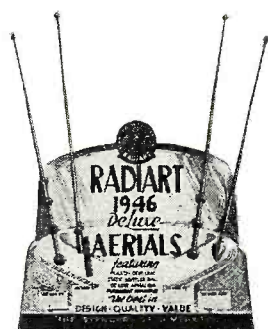

Ask your Radiart Jobber how you can get one of these snappy RADIART AERIAL COUNTER DISPLAYS.

Manufactured by the Makers of RADIART "Correct Replacement" Vibrators.



## Radiart Corporation

3571 W. 62nd STREET • CLEVELAND 2, OHIO

Export Division  
25 Warren St., New York 7, N.Y.

Canadian Office  
455 Craig St., W., Montreal, Canada



# Two Ghirardi books THAT TEACH YOU TO DO ANY REPAIR JOB ON ANY RADIO EVER MADE!



Meet Alfred A. Ghirardi—the man who makes Radio easy to learn!



## HOW TO TEST A RADIO IN 2 MINUTES or less!

Want to repair your own radios—without months of specialized service training? Want to repair sets for friends for fun or profit? Or, if you are already a radio serviceman, do you want to learn how to diagnose radio troubles in 2 minutes or less and fix sets TWICE AS FAST and TWICE AS PROFITABLY—without a lot of unnecessary testing? Then order Ghirardi's RADIO TROUBLE-SHOOTER'S HANDBOOK today—on a 5-Day Money-Back Guarantee!

## START A SERVICE BUSINESS . . . GET A BETTER PAYIN' JOB!

There's a real future for you in servicing—and Ghirardi's MODERN RADIO SERVICING is just the book to start you on it without delay. And remember: Radio is just the beginning! What this big book teaches you about Radio servicing, Test Instruments, and modern technical procedure is exactly the training you need to fit you to "grow up" with the fast-expanding Electronics profession in all of its servicing phases! It gives you real PROFESSIONAL Training . . . for only \$5 COMPLETE!

### MODERN RADIO SERVICING

## THE BOOK THAT GIVES COMPLETE MODERN Professional TRAINING

Once in a blue moon a technical book is written that is so important, so complete and so easy to understand that it is used and recommended universally by members of a profession. Ghirardi's MODERN RADIO SERVICING is exactly that kind of a book as leading radio men everywhere will quickly tell you!

### TEST INSTRUMENTS, TROUBLE-SHOOTING, REPAIR

Actually, MODERN RADIO SERVICING is the only single, inexpensive book giving a complete, easy-to-understand course in modern Radio repair work in all of its branches—branches that lead right through to all types of Electronic equipment. Written so simply you can understand it without an instructor! Read from the beginning,

it takes you step by step through all phases of the work. Used as a reference book by busy servicemen, it serves as a beautifully cross-indexed volume for "brushing up" on any type of work that may puzzle you.

Included is a thorough explanation of all Test Instruments, telling exactly how they should be used and why (it even gives complete data for making your own Test Equipment if you prefer!); Receiver Troubleshooting Procedure and Circuit Analysis; Testing & Repair of Components; Installations; Adjustments; etc., etc.—also, How to Start a Successful Radio-Electronic Service Business. 1300 pages, 720 self-testing review questions, 706 helpful illustrations and diagrams. Only \$5 complete (\$5.50 foreign).

### RADIO TROUBLE-SHOOTERS' HANDBOOK

## SPEED UP SERVICE WORK . . . FIX RADIOS AT HOME without elaborate test equipment

Radio servicemen everywhere say that this big new, 3rd edition of A. A. Ghirardi's RADIO TROUBLE-SHOOTER'S HANDBOOK (illustrated at right above) helps them turn out twice as much work in a given time! Radio beginners who like to fix radios for themselves and friends find it a quick, easy way of locating and repairing receiver troubles. Nine times out of ten, it tells how to repair a set—without any elaborate testing whatever!

### NOT A "STUDY" BOOK

Actually, this big 4-pound, 744 page manual-size RADIO TROUBLE-SHOOTER'S HANDBOOK is a complete guide to quick, easy repairs on PRACTICALLY EVERY RADIO RECEIVER NOW IN USE. It isn't a study book. You simply turn to it when you want to fix a particular type of trouble in a particular model and make of radio.

Its 404-page Case History section gives full details on common trouble symptoms, their causes and remedies for OVER 4,000 DIFFERENT RADIO RECEIVER MODELS. It describes the trouble exactly—tells exactly how to repair it. It eliminates extensive testing—helps you do two OR MORE jobs in the time normally required for one—repair cheap sets at a profit—substitute tubes and parts properly—train new helpers, etc., etc.

In addition, there are hundreds of pages of tube charts, graphs, data, i-f alignment peaks for over 20,000 superhets, tube and parts substitutions information, data on transformer troubles, etc.—all carefully indexed so that you can find just what you need in a hurry. This big, beautifully bound HANDBOOK costs only \$5 (\$5.50 foreign) on our UNRESERVED 5-DAY MONEY-BACK GUARANTEE.

## YOUR MONEY BACK IN 5 DAYS

Murray Hill Books, Inc., Dept. RN-16, 232 Madison Ave., New York 16, N. Y.

Enclosed find \$ . . . . . for books checked; or  send C.O.D. (in U.S.A. only) for this amount plus postage. If not fully satisfied, I may return the books within 5 days and receive my money back.

3rd Edition RADIO TROUBLESHOOTER'S HANDBOOK \$5 (\$5.50 foreign)

Ghirardi's MODERN RADIO SERVICING \$5 (\$5.50 foreign)

Special MONEY-SAVING COMBINATION: MODERN RADIO SERVICING and RADIO TROUBLESHOOTER'S HANDBOOK (both books) \$9.50 (\$10.50 foreign).

Name . . . . .

Address . . . . .

City & Dist. No. . . . . State . . . . .

## Special MONEY-SAVING OFFER

Get both of these big books at our special Money-Saving price—a complete servicing library of over 2040 pages for only \$9.50. (\$10.50 foreign.)



**723 OUT OF 817!**

Recently, a group of 817 radio instructors, students, repair men, radio men in the armed forces, in broadcast stations, big manufacturing plants, etc. were asked what they think of the various books and courses for the study of basic Radio-Electronics. 724 of these men—**NINE OUT OF TEN**—said that, in their opinion, **GHIRARDI'S RADIO PHYSICS COURSE** was their first choice—far better than any other **AT ANY PRICE!**

**"IT'S THE BEST OUT OF 20" SAYS CHIEF ENGINEER**

From F. S. Bailey, Chief Engineer, Radio Operator's School, Brownsville, Texas comes this sweeping endorsement of Radio-Electronic's greatest basic training book: "We find Ghirardi's **RADIO PHYSICS COURSE** the best book out of 20 or more that we have tried—both as a complete course in Radio Physics, and for all other branches. It is best for beginners as well as those who already know something about Radio . . . It is giving our students the very best for their money!"

**Who said it costs a lot of money to LEARN RADIO-ELECTRONICS?**



**Only \$5 COMPLETE**

**and it IS complete!**  
(\$5.50 foreign)

**972 pages—Over 500 illus.**

Used more widely by Army, Navy, and civilian schools and colleges and for more home study than any other book or course of its kind.

**THE BOOK THAT MAKES IT EASY FOR BEGINNERS TO LEARN AT HOME . . . without an instructor**

A. A. Ghirardi's 972-page **RADIO PHYSICS COURSE** gives you just the training you need—**ALL YOU NEED**—easier, better, faster—**AT A TOTAL COST OF ONLY \$5 Complete** (\$5.50 foreign). Actually this giant, profusely illustrated book is 36 courses in one. If broken into course form and sent to you in monthly lessons, you'd regard it a bargain at \$50 or more!

**FASTER - EASIER - MORE COMPLETE**

Nothing is omitted. Nothing is condensed. The book has been specifically designed for home study by *beginners*. You'll be pleasantly surprised to find how easily you'll master subjects that other books and courses make seem very complicated. And you'll be delighted to find how soon you can be doing interesting experiments, building radio equip-

ment, etc., as a result of what this book shows you. No previous Radio-Electronic knowledge is necessary. Ghirardi's **RADIO PHYSICS COURSE** book carries you rapidly through Basic Electricity (over 300 pages to this essential subject alone) to the latest, most modern Radio-Electronic developments. Each section is followed by Self-Testing Review questions that make it easy for you to check every step of your progress. There are no monthly payments to be bothered with—no monthly lessons for which to wait. Hundreds of enthusiastic readers have completed the book in a few short weeks! All you need is a little spare reading time plus a desire to get started now for a better-paying, more interesting future in the rapidly expanding fields of broadcasting, aviation radio, F-M, Television, radio servicing, electronic manufacturing—or any other of Radio-Electronic's fast growing branches.

More copies of this famous book have been sold

than any other type of basic Radio-Electronic Training. More men already making good money in Radio-Electronics will tell you that Ghirardi's **RADIO PHYSICS COURSE** is far and away the best buy you can possibly make. Mr. Ghirardi knows how to write simply and clearly so that you can understand it. He knows how to make technical subjects interesting. **PROOF?** Well send the coupon today. You cannot lose. If you are not **MORE THAN SATISFIED** simply return the book within five days and we'll gladly refund your money **AND NO QUESTIONS ASKED!** What could be fairer than this?

**ACT AT ONCE!**

Paper is still scarce. It may be impossible to reprint promptly after our supply is exhausted. Order yours today!



**Compares it with \$150 Radio Course!**

"I had already taken a \$150 radio course, but since I've read **RADIO PHYSICS COURSE**, I put the other one away. Ghirardi's **RADIO PHYSICS COURSE** is the real book I need because it teaches so clearly."

Gerard Champagne, Montreal, C.

**Wishes He'd Bought it Sooner**

"Only wish I'd known about **RADIO PHYSICS COURSE** sooner. I have already learned more from a few pages than I got from almost two years of intermittent study from other sources."

R. L. Lucas, Fort Worth, Texas

**YOUR MONEY BACK IN 5 DAYS**

if Ghirardi's **RADIO PHYSICS COURSE** doesn't teach you Radio-Electronic fundamentals **EASIER, FASTER, and at LESS COST** than any other book or course. You be the judge!

Murray Hill Books, Inc., Dept. RN-16, 232 Madison Ave., New York 16, N. Y.

Enclosed find \$5 (\$5.50 foreign) for which rush me a copy of A. A. Ghirardi's 972-page **RADIO PHYSICS COURSE** BOOK or

Send C. O. D. for \$5 (no foreign C. O. D.'s) plus postage. In either case, it is understood I may return the book within 5 days of its receipt and have my money refunded.

Name.....

Address.....

City & Dist. No..... State.....



UP FRONT...

*Every Time*

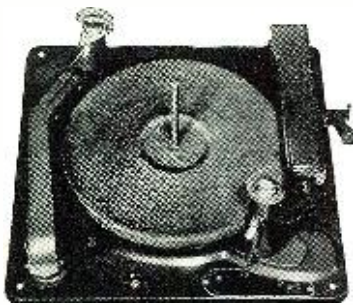

Combination record-changer recorder  
Model GI-RC130

You'll like our postwar line of Smooth Power motors, recorders and combination record-changer recorders. They are right up in front with high-quality, velvety smooth operation, perfect fidelity in recording or reproduction.

They have the same fine design and built-in qualities that deliver complete satisfaction, as always. There is no skimping of details to give us fast production. You'll have a front seat in the postwar markets with General Industries phonograph mechanisms.

THE GENERAL INDUSTRIES CO.  
Dept. M • Elyria, Ohio



tance tube. The 9003 is preferred because of its smaller physical size and lower filament current drain. Filament and plate voltages may be taken directly from the receiver with which the tuner is to be used. In this particular receiver, the super-pro, adequate plate voltage may be obtained at terminal number 6.

As previously stated, the audio remote lines are used as the control lines for the tuning device. A d.c. blocking condenser,  $C_s$ , inserted between the receiver audio output and the grid bias circuit of the reactance tube, serves to couple the audio into the remote lines. However, a complete d.c. circuit is required over the line itself, in order that potentiometer  $R_s$  at the operating position may control the grid bias of the reactance tube. For use in the amateur or other communications bands, the grid bias potentiometer control may be fitted with a calibrated dial at the operating position. In this manner, the control may be used to provide limited bandspread on either side of a selected communication frequency.

Tests have shown that the audio frequencies present in the control lines do not effect the operation or stability of the receiver tuning, nor were any adverse effects noted from any other interference encountered along ten miles of ordinary telephone wire connecting the receiver and the operating position. Experimenters, and engineers as well, can conceivably find many uses for a compact, simple, and inexpensive tuning device of this type.

-50-

### International Short-Wave

(Continued from page 43)

port, provided the country to which your report is addressed accepts such IRC's.

Here are additional comments from monitors contacted:

"Sometimes mentioning you are a member of a DX club or a monitor for RADIO NEWS helps considerably in getting a verification." (Balbi)

"Every time I send for a verie, I have my fingers crossed." (Black)

"I always tell them what big city is nearby and send along a post card or two. This way I always get more information about the station I heard." (Harris)

\* \* \*

### PCJ CALLS FROM HOLLAND

From Huizon, Holland, comes announcement that on October 13, 1945, regular daily short-wave broadcasts to the Netherlands East Indies, South Africa, Curacao and Surinam were resumed by radio station PCJ, before the war the chief Dutch transmitter to the Indies. The new broadcast schedule follows:

8-8:30 a.m., news and talks; 8:30-9 a.m., popular musical programs; 9-9:30 a.m., greetings from Hollanders to relatives; over 15.220 (19.71 m.), beamed to the Netherlands Indies.

2-3 p.m., first two parts of Indies transmission, over 9.590 (31.28 m.), beamed to South Africa.

8-9 p.m., first two parts of Indies transmission, beamed to Curacao and Surinam.

During the war the 15.220 frequency was used by Canadian station CHTA, which would have jammed the Indies transmission by PCJ, so the regular program could not be started until negotiations had been completed to restore the band to PCJ, comments Aneta (Dutch) News Agency. An earlier announcement had stated that PCJ would broadcast to the Indies from 1 to 2 a.m., but the broadcast is from 8 to 9:30 a.m. daily.

Preliminary tests were carried out for some weeks prior to the inauguration of the regular schedule on October 13, and Aneta reports that letters received by PCJ from the Indies disclose that reception was excellent during the preliminary test period

PCJ is coming through with an excellent signal in the East during the morning broadcast on 15.220. The period 8:30-9 a.m. is especially interesting, with English announcements as well as Dutch, French, and sometimes Spanish. Some days, greetings are read in English. Apparently PCJ's studios are located in Hilversum, "the Happy City."

\* \* \*

### SERVICES FROM WWV

Starting in October 1945, a new feature was added to the continuous standard-frequency and standard-time-interval service broadcast from the National Bureau of Standards radio station WWV near Washington, D. C., that of time announcements in telegraphic code each five minutes.

The services now include: (1) standard radio frequencies; (2) standard time intervals, accurately synchronized with basic time signals; (3) standard audio frequencies; (4) standard musical pitch, 440 cycles per second, corresponding to A above middle C; and (5) time announcements.

The standard-frequency broadcast service makes widely available the national standard of frequency, which is of value in scientific and other measurements requiring an accurate frequency.- Any desired frequency may be accurately measured in terms of the standard frequencies.

Four radio carrier frequencies are broadcast from 10-kilowatt radio transmitters except on 2500 kilocycles per second, where 1 kilowatt is used. Three or more transmitters are on the air at all times, to insure reliable coverage of the United States and other parts of the world. The radio frequencies used are:

2.5 megacycles (2500 kilocycles or 2,500,000 cycles) per second, broadcast from 7 p.m. to 9 a.m. EST (2400 to 1400 GMT).

5 megacycles (5000 kilocycles or 5,000,000 cycles) per second, broadcast continuously day and night.

10 megacycles (10,000 kilocycles or 10,000,000 cycles) per second, broad-



COMING IN MARCH

# The BIG book of the plastics industry

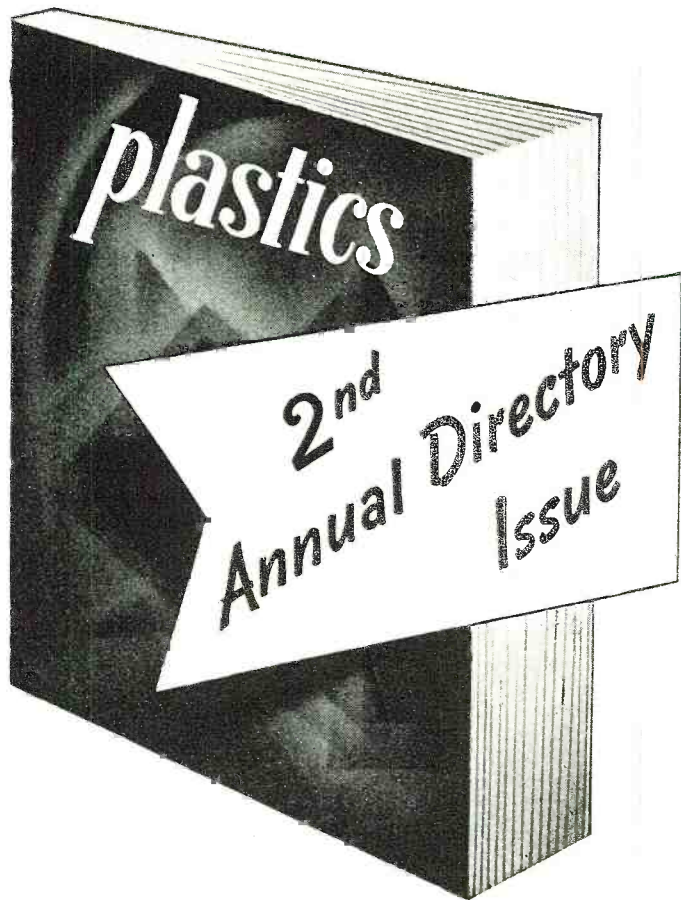

*plastics* First Annual Directory made history in the plastics field. The SECOND ANNUAL DIRECTORY, which will appear as part of the March issue of *plastics*, will be even more inclusive, more informative than the great 1945 book. The 1946 issue will be thoroughly revised, expanded and enlarged, with much new material added. Its hundreds of pages will contain essential year-long information for everyone who is in any way interested in plastics or plastics products. In addition to informative editorial matter, there will be many directory features including:

- Tables and graphs of plastics properties and characteristics
- Directories of plastics materials, chemicals, machinery
- Plastics components, and war plastics now available
- List of plastics trade names
- A glossary of plastics terminology
- Products available from stock molds
- A comprehensive directory of companies and individuals engaged in all phases of the plastics industry

Sent to All Subscribers at No Extra Cost

## The vital all-year reference for the plastics industry

Be sure of your copy  
of the Directory Issue  
Subscribe now to

### *plastics*

3 years . . . . . \$10.00  
2 years . . . . . \$ 8.00  
1 year . . . . . \$ 5.00

(Including the  
March Directory Issue)

PLASTICS Second Annual Directory Issue (March 1946) will be sent to all subscribers AT NO EXTRA COST. Guaranteed only to regular subscribers.

### *plastics*

185 N. WABASH AVENUE CHICAGO 1, ILL.  
Enter my Subscription to **PLASTICS**

3 YEARS . . . \$10.00 • 2 YEARS . . . \$8.00 • 1 YEAR . . . \$5.00  
(TO INCLUDE THE ANNUAL DIRECTORY ISSUE AT NO EXTRA COST)

Remittance Enclosed  Bill Me Later

Name \_\_\_\_\_

Address \_\_\_\_\_

Please indicate if above is  Home Address  Business Address

City \_\_\_\_\_ Zone No. \_\_\_\_\_ State \_\_\_\_\_

Company \_\_\_\_\_

Product Manufactured \_\_\_\_\_

Title \_\_\_\_\_

Canadian Subscriptions 50c per year, extra PD-1



**Solder  
Fast**

**TRIGGER CONTROL...  
EASY HANDLING**



Pats. Pending

• The BAKER Flash is the revolutionary gun-type soldering iron that answers industry's demand for a FASTER, HANDIER tool, for precision work in close places.

The tip flashes to soldering heat almost instantly following pressure on the trigger control. Correct temperature for most efficient work is easily maintained, overheating and unnecessary oxydation avoided, cleaning and re-tinning time saved.

Natural gun grip; cool, protected plastic handle; light weight; perfect balance—these are advantages that make the BAKER flash extremely easy to use, ideal for work in close places.

Completely equipped for immediate operation from 110-volt transformer or from standard storage battery.

Distributors—Here is Something You Can Get NOW—  
Something You Can SELL NOW—Interesting proposition.

ORDER SAMPLE TODAY—Only \$4.75 Postpaid. With HT Transformer \$9.95  
Remit check or money order unless C.O.D. is preferred.

Write or  
Wire for  
Complete  
Information

**BAKER-PHILLIPS COMPANY**

3059 LYNDALE AVE. SO.  
MINNEAPOLIS 8, MINNESOTA

**PHONO-AMPLIFIER**

A compact phonograph amplifier  
—ONLY one tube, but compara-  
ble to most 3-tube amplifiers. Built  
into sturdy metal chassis.

The amazing efficiency of this small  
amplifier will pleasantly surprise  
and satisfy you.

\* \* \*

We also manufac-  
ture all types of  
coils and pick-ups.  
Send your specifica-  
tions and we will  
gladly quote prices.

\* \* \*

Write for our new,  
illustrated literature.

We regret our inability  
to answer previous in-  
quiries, but assure you  
that information is now  
being mailed.

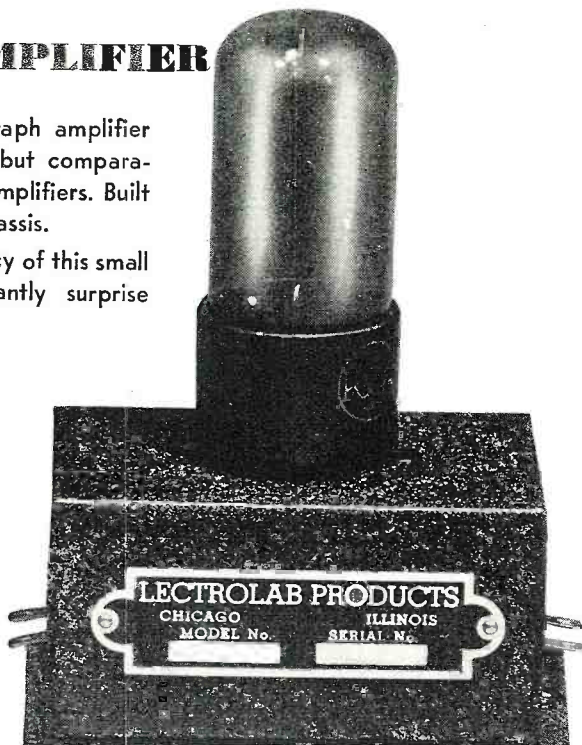

**LECTROLAB PRODUCTS**

Manufacturers and Designers of Electronic Devices

2806-10 W. HARRISON STREET • CHICAGO 12, ILLINOIS

cast continuously both day and night.  
15 megacycles (15,000 kilocycles or  
15,000,000 cycles) per second, broad-  
cast continuously day and night.

Two standard audio frequencies, 440  
cycles per second and 4000 cycles per  
second, are broadcast on the radio car-  
rier frequencies. Both are broadcast  
continuously on 10 and 15 megacycles.  
Both are on 5 megacycles in the day-  
time, but only the 440 is on 5 mega-  
cycles from 7 p.m. to 7 a.m. EST. Only  
the 440 is on 2.5 megacycles

Eastern standard time is announced  
in telegraphic code each five minutes.  
The zero- to twenty-four-hour system  
is used starting with 0000 at 12:00 p.m.  
EST. The first two figures give the  
hour and the last two figures give the  
number of minutes past the hour. The  
time announcement occurs immedi-  
ately after the beginning of each five-  
minute interval. At the hour and half-  
hour it is followed by the station an-  
nouncement in voice.

Of the radio frequencies on the air  
at a given time, the lowest provides  
service to short distances, and the  
highest to great distances. Reliable  
reception is in general possible at all  
times through the United States and  
the North Atlantic Ocean, and fair re-  
ception throughout the world.

Information on how to receive and  
utilize the service is given in the Na-  
tional Bureau of Standards letter cir-  
cular *Methods of Using Standard Fre-  
quencies Broadcast by Radio*, obtain-  
able on request. The bureau welcomes  
reports of difficulties, methods of use,  
or special applications of the service.  
Correspondence should be addressed to  
National Bureau of Standards, Wash-  
ington 25, D. C.

\* \* \*

**"WAY DOWN UNDER"**

A late report from Cleve Maher,  
Gladesville, N.S.W., Australia, lists:  
FO8AA, 6.980, Papeete, Tahiti, clos-  
ing at 2:30 p.m. in French.

FK8AA, 6.208, Noumea, New Cale-  
donia, fine at 3 a.m.

VPD2, 6.130, Suva, Fijis, fine at 2:30  
a.m.; slow-speed news at 3:30 p.m.

In New Zealand, ZLM5, 15.550, has  
been testing at 2:15 p.m., 8 p.m., 10  
p.m, relaying New Zealand broadcast  
stations, beamed to the US.; ZLN4,  
9.870, similar test services as ZLM5  
but at 2:15 a.m., 4:15 a.m., and 4:45  
a.m. These stations are operated by  
Posts and Telegraph Department and  
use 5,000 watts. Location is Wellin-  
ton. ZL1, 6.080, ZL2, 9.540, ZL3, 11.780,  
and ZL4, 15.280, are not yet in use, ac-  
cording to Mr. Maher.

Of the Australians on short-wave,  
VLQ, 7.240, Brisbane, relays ABC do-  
mestic programs, 3-7 p.m.; VLQ2, 7.215,  
2:30-8 a.m.; VLQ3, 9.660, 8:45 p.m.-  
2:45 a.m. weekdays, and 8 p.m.-2:15  
a.m. Sundays VLW3, 11.830, Perth, re-  
lays ABC domestic programs week-  
days, 10:30 p.m.-5:15 a.m., and 11 p.m.-  
5:15 a.m. Sundays: VLW7, 9.520, sched-  
uled weekdays. 5-8:45 p.m., 5:30 a.m.-  
10:30 p.m., and Sundays, 5:45-8:40 p.m.  
and 5:30 a.m.-11 p.m. VLR, 9.580, Mel-  
bourne, Sundays, 3:45 p.m.-2:45 a.m.,

**RADIO NEWS**



# A New Jensen Coaxial

## TYPE H

### WITH *Compression-type* HIGH-FREQUENCY SPEAKER

The first of a new series of JENSEN Coaxial Speakers, combining in one coaxial assembly a horn-type high-frequency speaker with a cone-type low-frequency unit. By unique design, the cone of the low-frequency unit forms a part of the high-frequency horn, thereby dispensing with a separate horn. An integral two-channel network gives the desired crossover characteristics. Thus this new Coaxial Speaker provides the quality of reproduction so essential and desirable for radio receivers and phonographs for home entertainment, particularly for FM reception and high quality phonograph recordings.

The distribution characteristics of the Type H Coaxial are excellent and, when installed in a suitable enclosure such as a Bass Reflex cabinet, its performance covers the entire frequency range useful in home reproduction.\*

Type H Coaxial, illustrated here with field coil low-frequency speaker and *ALNICO 5* high-frequency unit, is designed for manufacturers. Other models for more general use, incorporating *ALNICO 5* design in both high-frequency and low-frequency units, will shortly be announced.

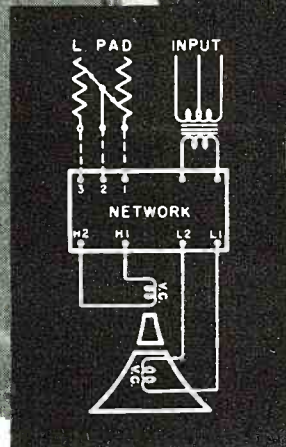

Low Frequency Motor

High Frequency Driver

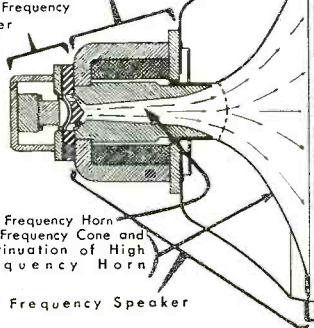

High Frequency Horn  
Low Frequency Cone and  
Continuation of High  
Frequency Horn

Low Frequency Speaker

## TYPE H SPECIFICATIONS

Power rating 25 watts maximum, in speech and music systems. Input impedance 16 ohms. Field 14-20 watts. List price approximately \$100.00.

\*See No. 3 JENSEN Monograph: "Frequency Range in Music Reproduction," for discussion of useful frequency ranges.

## Other Coaxials Now Available!

These Type J Coaxials, improved over prewar design, offer low-cost Coaxial performance in home radio receiver and phonograph entertainment.

**JAP-60** (1.5-inch) with HF Control Switch. List price **\$79.45**

**JHP-52** (1.5-inch) with HF Control Switch. List price **\$36.15**

**JCP-40** (1.2-inch) HF Level Control extra. List price **\$33.45**



# Jensen

SPEAKERS WITH

# ALNICO 5

JENSEN RADIO MANUFACTURING COMPANY • 6617 S. LARAMIE AVE. • CHICAGO 38, ILLINOIS  
IN CANADA—COPPER WIRE PRODUCTS, LTD. • 137 OXFORD STREET, GUELPH, ONTARIO

*Specialists in Design and Manufacture of Fine Acoustic Equipment*





R. C. (Dick) Hall  
WSEIB

## R. C. & L. F. HALL

1015-17 Caroline St.  
Dept. N  
HOUSTON 2, TEXAS

We are getting to where we look forward to this opportunity to talk to you each month about merchandise in which you are interested.



L. F. (Lillian) Hall  
WSEUG

### "ACROSS THE OPERATING TABLE"

Now that the ten meter band has opened up again and stations are pouring in from coast to coast, we know amateurs are principally interested in new receivers, transmitters and parts. We are not going to "kid" you about the large number of receivers we have in stock because we are one of the largest distributors of amateur equipment in the country and, as you know, the demand greatly exceeds supply. However, as this is written (November 20, 1945) Hallcrafters and RME are shipping various models right along while Hammarlund, Millen and National are promising early January (about the time you are reading this) delivery. We have had large orders in for a long time and as you read this we should be getting many communications receivers and shall be glad to have your order for the one you want or your inquiry about details. Ask for our amateur bulletin, "Across the Operating Table," in which we list parts and other amateur merchandise.

### "ACROSS THE SERVICE BENCH"

is the title of our service dealer bulletin, which goes to about seven thousand Service Dealers in Arkansas, Louisiana, Mississippi, New Mexico, Oklahoma and Texas, as well as other parts of the country. If you are not getting this bulletin we shall be glad to put your name on our mailing list on request and we suggest you ask for a "new customer" tube allocation, mentioning this advertisement.

### TO INDUSTRIAL AND GEOPHYSICAL BUYERS

We are in a position to take care of a great many of your requirements. We have a number of amateurs in our organization and sometimes we can be of assistance on your technical problems. In addition, we carry a selection of the finest lines of the electronic merchandise to be found in the country. We'll welcome your inquiry.

### A FEW OF THE MANUFACTURERS WHOSE PRODUCTS WE DISTRIBUTE

Aerovox	Cinaudagraph	GE	Leach	Ohmite	Setchell-Carlson
Amphenol	Drake	Hallcrafters	Les Logan	Peerless	Silver
Astatic	Dumont	Hammarlund	Littlefuse	Pioneer	Stancoor
B&W	Echophone	Hytron	John Meck	Precision	Taylor
Belden	Eimac	Insuline	Meissner	Premax	Thordarson
Bliley	Electronics Lab.	Jensen	Millen	RCA	Trim
Bud	Gammatron	Johnson	Mueller	RME	Triplett
Centratlab	General Cement	Kaar	National	Sansamo	Turner

and weekdays, 3-4:10 p.m. and 3-8:30 a.m., and to 9 a.m. on Saturdays only; relays 3AR and 3LO on ABC programs; VLR3, 11.880, 4:20 p.m.-2:45 a.m. weekdays, and 4:45 p.m.-2:45 a.m. on Sundays. VLG, 9.580, Melbourne, is heard 9:15-9:45 a.m. to India; VLG3, 11.710, 1-1:40 a.m. to Tahiti in French, 1:55-2:25 a.m. to British Isles, 2:30-2:55 to Asia in Japanese, 8:55-10:45 p.m. and 12:10-12:45 a.m. to U.S.; VLG5, 11.800, 10-11 a.m. to U.S.; VLG6, 15.230, 10-11:30 p.m.; VLG7, 15.160, 3-5 p.m., relay of ABC National Programs, with POW program from 3AR, 6:15-7:15 p.m.; VLG9, 11.900, 7-8:35 a.m. to Asia (Malay to 7:35 a.m., then news in English, with French at 8 a.m.); VLG10, 11.760, 3:10-3:55 a.m. to New Caledonia in French, 4-5:15 a.m. to Southwest Pacific, and 6:15-6:30 a.m. to Asia in Chinese.

VLC2, 9.680, Shepparton, 2:30-3:45 a.m. to Britain weekdays, and to 3:30 a.m. on Sundays; VLC4, 15.315, 5:30-6:15 p.m. to Asia; 6:15-7:15 p.m., POW program; 8:55-10:45 p.m. to U.S.; 10-11 p.m. (to 11:30 Sundays) to Southwest Pacific; 11 p.m.-12 midnight (11:30 p.m.-12:30 a.m. Sundays), being a relay from BBC for Royal Navy; and 12:10-12:45 a.m. to U.S. VLC5, 9.540, 8-8:45 a.m. to U.S. VLC6, 9.615, 10-11 a.m. to U.S.; 4-5:15 a.m. to Southwest Pacific; 5-15-6:45 to Asia in English, Malay, and Dutch; 8-9:30 a.m. to Asia in French, Thai, English; 9:35-9:45 a.m. to India. VLC7, 11.840, 1-1:40 a.m. to Tahiti in French.

English newscasts quoted by Mr. Maher from the *ABC Weekly* include: ZOJ, 11.810, Colombo, Ceylon, and Singapore Radio, 9:55, at 9:30 a.m.; Delhi, 9.630, 9:50 a.m.; Radio Bierut, 8.020, 10 a.m.; Chungking, 9.805, 10:05 a.m.; TAP, 9.465, Ankara, 11:45 a.m.; Warsaw, 6.115, 3 p.m.; Delhi, 15.350, 7:45 p.m.; ZOJ, 15.275, Colombo, 10 p.m.; Delhi, 15.350, 10:30 p.m.; ZOJ, 15.275, Colombo, 11:30 p.m.; Singapore, 15.360, 11:30 p.m.; Delhi, 15.350, 1:30 a.m.; Moscow, 15.330, 1:30 a.m.; Singapore, 15.360, 3:30 a.m.; Delhi, 15.350, 4:30 a.m.; Wellington, New Zealand, 6.715, 4:30 a.m.; Hongkong, 9.500, 5 a.m.; ZOJ, 11.810, Colombo, 5:30 a.m.; Chungking, 9.805, 6:30 a.m.; Delhi, 15.160, 6:30 a.m.; Moscow, 9.566, 6:40 a.m.; ZOJ, 11.810, Colombo, 7:30 a.m.; Chungking, 9.805, 8 a.m.; and Delhi, 15.350, 8:30 a.m.

\* \* \*

### SOUTH AFRICANS

E. Hughes, for the chief engineer, South African Broadcasting Corporation, Broadcast House, Commissioner Street, P.O. Box 4559, Johannesburg, South Africa, informs us that they "are now in a position to send out QSL cards in verification of reception of South African transmitters and do not require an international reply coupon." An attractive green-and-gold verification card was received with Mr. Hughes' letter, verifying our July 1945 reception of ZRK, 5.885, Capetown. It seems that verifications are sent out direct from the SABC in Johannesburg. (Continued on page 100)

RADIO NEWS

# IT'S NEW! IT'S POST-WAR SUPREME Model 565 VACUUM TUBE VOLTMETER

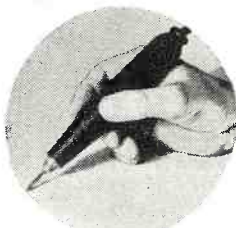
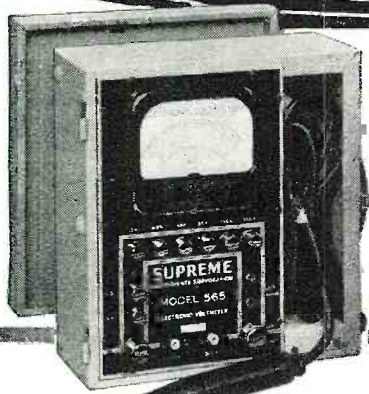

NEW PROBE Streamlined  
Hand Fitting. Incorporating  
new High Frequency Diode

#### RANGES:

DC 0-1, 2.5, 10, 50, 250, 500  
AC 0-1, 2.5, 10, 50, 250

EXTENDED TO 5000 VOLTS BY EXTERNAL MULTIPLIERS

#### INPUT RESISTANCE:

DC—80 megohms on 1 volt range; 40 megohms on 500 volt range  
AC—40 megohms on 1 volt range; 20 megohms on 250 volt range

INPUT CAPACITY OF PROBE: 5 micro-micro farads

#### FREQUENCY RANGE:

Negligible frequency error from  
50 cycles to 100 megacycles.

SUPREME INSTRUMENTS CORPORATION

GREENWOOD  
MISSISSIPPI



**It won't be long now!**

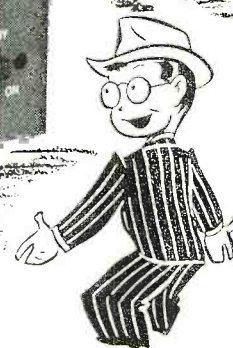
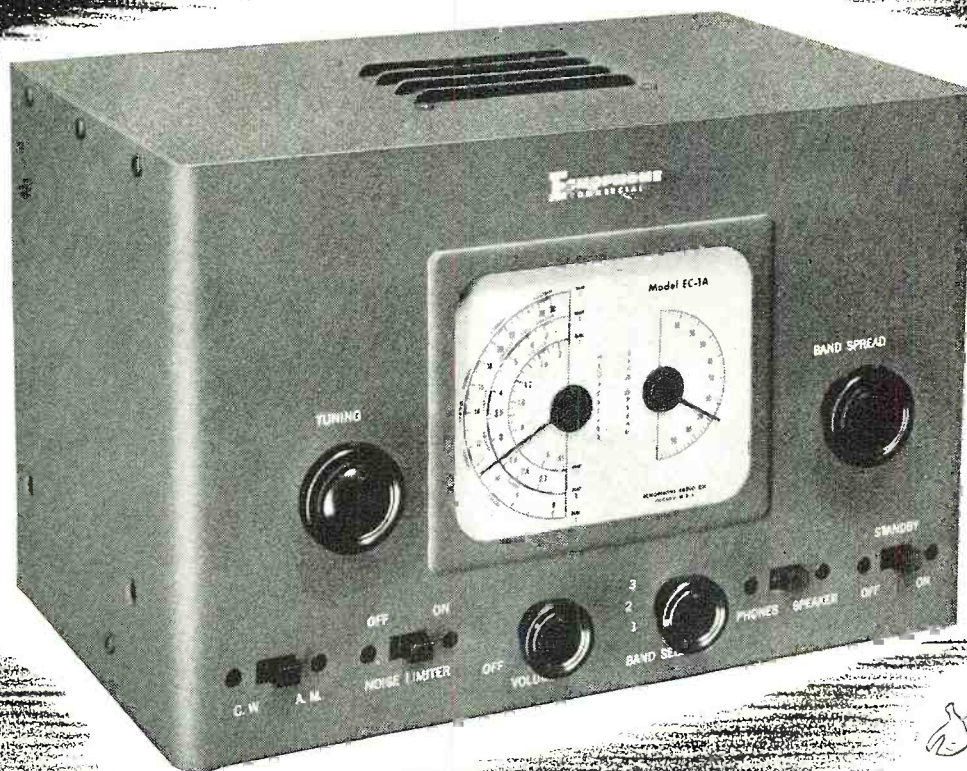

## **ECHOPHONE MODEL EC-1A**

*A real communications receiver  
at a sensationally  
low price*

Nearer and nearer to reality comes Hogarth's dream of a real communications receiver at a sensationally low price. Now available—or very soon—the 1946 Echophone, Model EC-1A, a 6-tube AC/DC communications receiver of outstanding value. With electrical bandspread throughout its frequency range of .55 to 30 megacycles, BFO for CW reception, and a new automatic noise limiter to suppress interference from automobile ignition, etc., the EC-1A provides genuine communications receiver performance in the lowest price range. Standard 115-volt AC or DC operation; also available for 200 to 250-volt operation.

# **ECHOPHONE**

ECHOPHONE DIVISION • THE HALLICRAFTERS CO.  
2611 INDIANA AVENUE • CHICAGO 16, U.S.A.



January, 1946

87



# TELEVISION For Urbanized Areas

By

GEORGE DUVALL

**Important facts for servicemen to know when installing antennas for television receivers in urban localities.**

HERE can be no doubt that television as a medium of transmission and reception has come of age. Today, in the greater New York City area, there are about five thousand receivers—a certain acknowledgment of the medium's progression. However, the story of their installation reveals difficult days ahead for those technicians who will assume the job.

The problems to be overcome in the installation of television receivers in a highly urbanized area are many and, unless they are properly approached, the results will be most confusing and detrimental to volume sales of receivers. Experience in this case becomes the best teacher, with trial and error often the only means of developing a clear understanding of the subject. However, there are certain practical procedures which should be followed.

It must be understood that television transmission is by line-of-sight propagation, thus permitting the signal to be received only when the wave front is either directly able to approach the set or makes its way to it through some reflective means. This places the problem of a highly urbanized installation within its proper sphere. The difficulties should be recognized for what they are, so the approach can be a simple and direct one.

The most typical of a highly urbanized area is New York City. With its buildings that prod the clouds and its densely accumulated apartment houses, it brings into full view the labor and ingenuity necessary to have a television installation set up to receive a signal amidst distracting physical barriers.

Therefore, to proceed in the installation of a television receiver, the initial step to be followed is one of physiogeographic consideration. The installer should fully realize that setting up a receiver within the confines of a build-

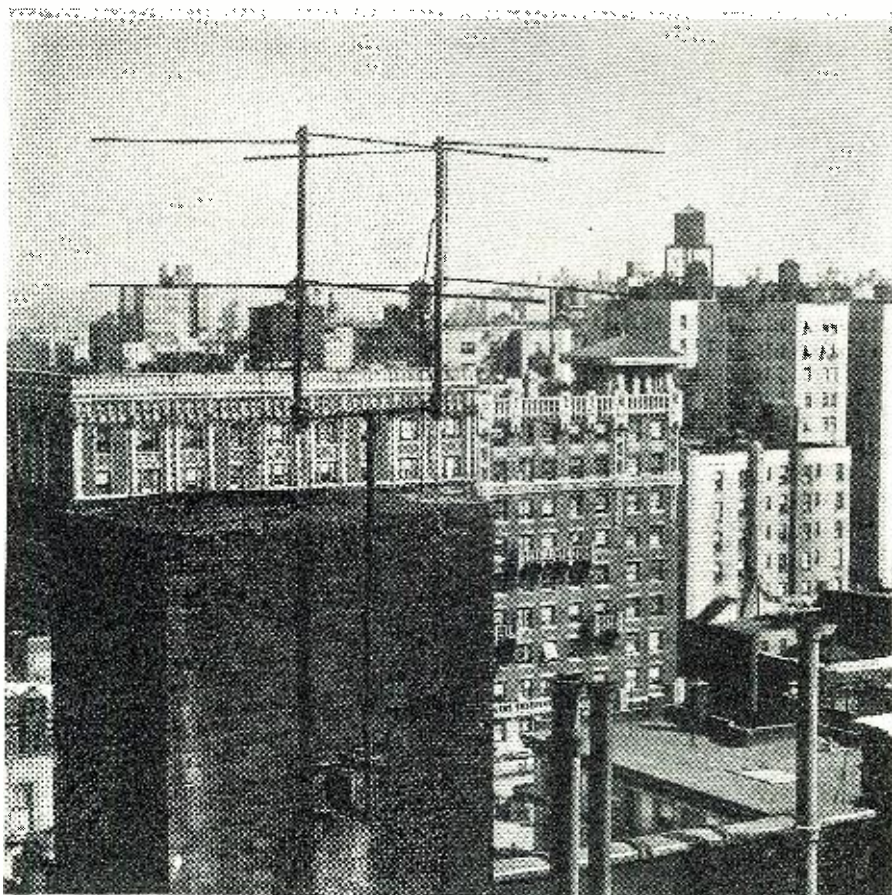

Photograph illustrates the various and many geographic barriers which must be considered when installing television receivers in highly urbanized areas.

ing area necessitates a careful analysis of just how to gain line-of-sight reception. This, naturally, can be achieved in its perfect sense only if the transmitting antenna and the receiving antenna are in full view of each other. However, under these circumstances, such a condition is rarely possible. The serviceman must then proceed by attempting to find out just what alternative methods can be used to bring in the desired signal.

Thus, the problem of costs becomes the apparent conditioner of just what can be done. The person owning the

receiver will have to pay proportionate to the additional materials and man-hours used. Relatively small cost will affect a line-of-sight location where the receiving antenna necessitates a short lead-in to the receiver. This, as you can undoubtedly see, is in most cases impossible in the New York City area. The alternative becomes one of figuring out a simple and inexpensive means for gaining a receiving antenna placement which will allow for good reception. In some instances, it will be necessary to place the television antenna on a neighbor's home. It can obviously be seen that additional costs will prevail when more expensive lead-in and complicated antenna arrays are needed.

There have been many cases where a television installation did not bring in a good signal, although its position was apparently favorable. The causes are many and varied. First, a likely possibility could be that the antenna is not high enough to allow for sufficient signal strength. Second, high loss transmission line impairs the strength of the received signal. Third, the dipole may not be of correct size and shape, or oriented correctly to allow for maximum signal reception. Last, due to unforeseen physio-geographic hindrances, the reflected beam may be

Fig. 1. When reflected waves from nearby buildings reach the television receiver at nearly the same intensity as the direct wave, picture distortion results.

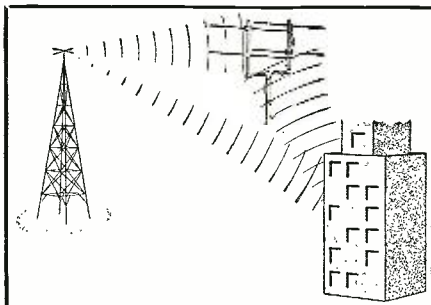



**THE RCA 815  
WILL GET YOU UPSTAIRS  
AT LESS COST**



**28-29.7 Mc**

**50-54 Mc 144-148 Mc**

**HANDLES 67 WATTS INPUT AT 144-148 Mc WITH 450-VOLT SUPPLY AND LESS THAN 0.5-WATT TUBE DRIVE**

**T**HE RCA-815 Push-Pull Beam Power Tube, originally developed for the amateur, was extensively employed in wartime mobile and aircraft transmitter designs because of its high power sensitivity, high efficiency, and low plate-voltage requirements.

Now the 815 is again ready to do service in the amateur high-frequency bands.

Priced at only \$4.50, it is the answer to a low-cost CW rig that can be operated from a simple power supply using receiver-type rectifier tubes, and can be driven to full output directly from a doubler stage.

Used as a plate-modulated r-f power amplifier, the 815 will deliver approximately 30

watts output at 144-148 Mc with only 360 volts on the plates and less than 0.5-watt tube drive!

The beam-power principle of the 815 accounts for its high efficiency and unusual economy on all bands from 2 to 20 meters. Good reason why you will want to use it.

See your local Amateur Tube Distributor.

Your UHF receiver will gain more from Acorns

**THE FOUNTAINHEAD  
OF MODERN TUBE  
DEVELOPMENT IS RCA**

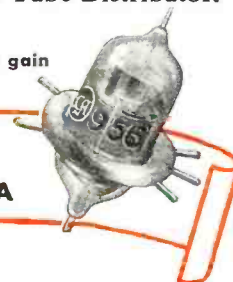

**TUBE DIVISION**

**RADIO CORPORATION of AMERICA**

**HARRISON, N. J.**



# HARVEY

now has for delivery  
long awaited  
**PRESTO PRODUCTS**

As the supply situation relaxes, HARVEY can supply more and more famous radio and electronic components and equipment, such as the dependable Presto recorder and transcription playback described below. Avail yourself of our rapidly growing stocks, our fast, efficient service, our technical know-how! Get the equipment you need now by placing your order promptly.

## PRESTO Model "K" RECORDER



A portable sound recorder, record player and public address system. Complete in a single carrying case. The Model "K" records 15 minutes continuously at 33 $\frac{1}{3}$  RPM on side of 13 $\frac{1}{4}$ " disc. It also makes 6, 8, 10, and 12 inch records, and plays all makes of phonograph records. With its many exclusive features found in no other low priced recorder, the user is able to make high quality recordings consistently, reducing spoilage cost of discs and needles. As a voice amplifying system, it serves audiences of about 500 persons.

## PRESTO Model "L" TRANSCRIPTION PLAYBACK



For those who demand "something better" in portable reproducing equipment. Small, light weight, easy to operate.

Its extreme simplicity and remarkably clear, wide range reproduction have made the Model "L" a favorite of radio stations, advertising agencies and program producers. It consists of a 12" dual speed rim-driven recording turntable, a 16" pickup on a swivel mounting which folds into the case when not in use, a 4 $\frac{1}{2}$  watt amplifier and an 8" loudspeaker, mounted in a single case. The speaker mounted in the case cover is equipped with a 20' extension cable. Semi-permanent needle supplied as initial equipment.

Telephone Orders to LO 3-1800

**HARVEY**  
**RADIO COMPANY**  
**HARVEY**  
103 WEST 43rd ST., NEW YORK 18, N. Y.

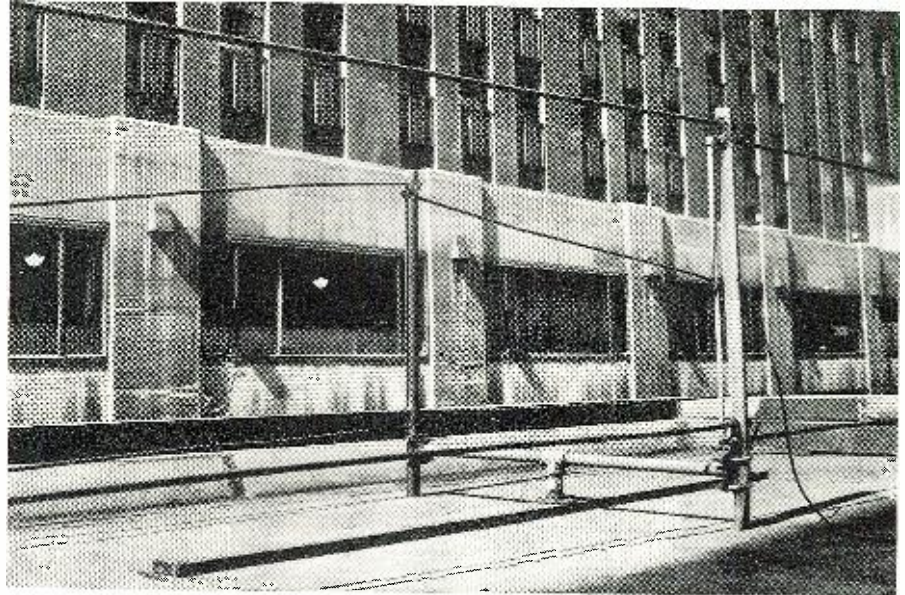

This antenna above the marquee of the Embassy Newsreel theater is situated between two of the tallest buildings in New York City. Reception occurs here when signal bounces off neighboring walls.

equal to the direct, in strength, causing disturbing multiple images on the screen (Fig. 1).

Correction of these potential problems are simple and feasible. The antenna height very well can determine the type of signal to be received. Presently, there is no other solution in gaining the exact height of the antenna than by the drawn-out process of trial and error. Only through tests can it be proved that a specific antenna ceiling will produce a good signal.

The question of just what part the use of coaxial cable can play in providing good reception, depends upon the particular case at hand. No general rule can be established which can formulate the type of cable necessary. Each set-up with its varied and difficult physical conditions will determine this. Low loss cable tends to raise the strength of the received signal and, if this is necessary in the individual case, the problem can be solved. Time alone will attest to the direction that the use of cable will have on an effective television installation. The war has brought many new types of cable to the fore which will tend to give

greater efficiency as well as lower cost, since one of the primary reasons for high cost in an urbanized installation is due to the use of a great amount of lead-in.

Of great importance in gaining the best possible reception is the proper orientation of the dipole. This can be achieved only by revolving the antenna set-up until the video signal is at its best. It doesn't necessarily follow that the dipoles must be facing the transmitting antenna. The point which provides the best possible picture is the answer. In relation to this, one particular occasion can be recalled where the dipoles were spread out on the ground, and yet the picture was received at its maximum.

With all conditions made favorable as far as mechanical procedure is concerned, the physical problem can easily upset the apple cart. To conceive of an ideal installation amidst the complicated building arrangements of the New York area is foolish. There is no arrangement which can suffice for every physio-geographic condition that arises. Each set-up must be treated with a technician's intelligence and a layman's horse-sense. Too often an entire installation is built up with complete neglect of the area in which it is installed. There are many cases, with full consideration of costs, in which it is impossible to gain a direct beam to the receiving antenna. In these instances, which are not infrequent in a highly urbanized area, the reflective beam must then be utilized. These rays, as shown in Fig. 2, can be picked up as they bounce off nearby walls or as they are turned back by physical impediments.

Another difficulty which we must comprehend is that of the receiver's ability to pick up all available television stations. To a large degree, this is possible under ordinary installation conditions by merely orienting the antenna dipoles. However, orientation

Fig. 2. If direct line-of-sight is not possible, advantage may be taken of the reflected wave by properly rotating the antenna to obtain maximum performance.

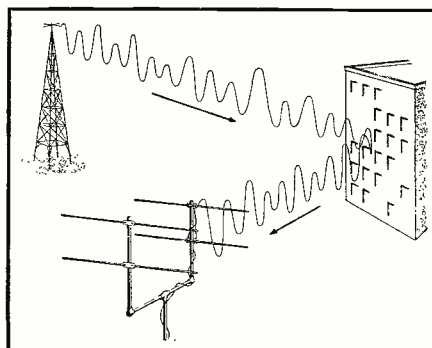



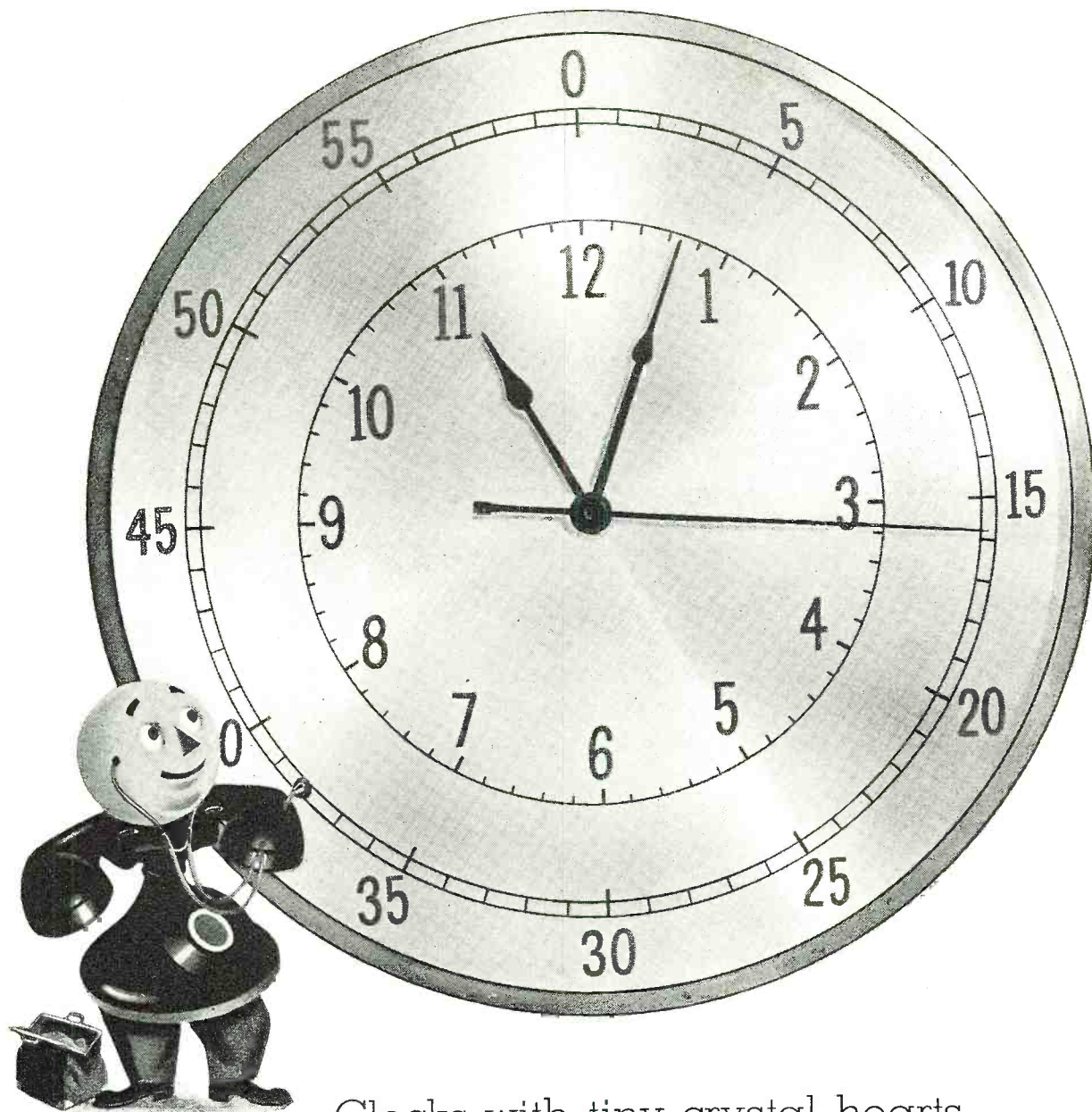

## Clocks with tiny crystal hearts that beat 100,000 times a second

CRYSTAL HEARTS beat time in Bell Telephone Laboratories, and serve as standards in its electronics research. Four crystal clocks, without pendulums or escapements, throb their successive cycles without varying by as much as a second a year.

Precise time measurements may seem a far cry from Bell System telephone research, but time is a measure of frequency, and frequency is the foundation of modern communication, whether by land lines, cable, or radio.

These clocks are electronic devices developed by Bell Laboratories, and refined over years of research. Their energy is supplied through vacuum tubes, but the accurate timing, the controlling heart of the clock, is provided by a quartz crystal plate about the size of a postage stamp.

These crystal plates vibrate 100,000 times a second, but their contraction and expansion is submicroscopically small—less than a hundred-thousandth of an inch. They are in sealed boxes

to avoid any variation in atmospheric pressure, and their temperatures are controlled to a limit as small as a hundredth of a degree.

Bell Laboratories was one of the first to explore the possibilities of quartz in electrical communication, and its researches over many years enabled it to meet the need for precise crystals when war came. The same character of research is helping to bring ever better and more economical telephone service to the American people.



**BELL TELEPHONE LABORATORIES** Exploring and inventing, devising and perfecting for continued improvements and economies in telephone service.



*"The Best of Everything for '46"*

**SUPERIOR INSTRUMENTS Co.**  
**Multitesters**

**MODEL PB 100**

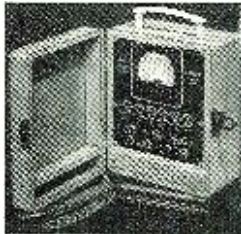

RANGES:  
D.C. VOLTAGES: (at 1,000 ohms per volt) 0 to 5-25-50-250-500-2500 volts.  
A.C. VOLTAGES: (at 500 ohms per volt) 0 to 10-50-100-500-1,000 volts.  
OUTPUT METER RANGES: Same as A.C. voltages.  
RESISTANCE: 0-10,000 ohms-0-100,000 ohms-0-1 megohm.  
D.C. CURRENT: 0-10-250 MA, 0-2.5 amperes.  
DECIBELS: -10 to +15DB, 0 to +35DB, +30 to +55DB.

Complete with batteries, ready to operate

**\$28.40** ea.

**RADIO CITY PRODUCTS**  
**MODEL 442-A**

3" square meter has a movement of 200 microamperes and a sensitivity of 5,000 OHMS PER VOLT. All scales can be easily read...

**\$23.65** ea.

**MODEL 492**

Volt — ohm — milliammeter up to 50 megohms.  
Special

**\$58.50** ea.

F.O.B. CHICAGO • WRITE DEPT. N FOR OUR LATEST CATALOGUE. • All foreign orders payable in U. S. funds

**COMPLETE LINE OF MICROPHONES**



**2 Burner Electric Hot Plate**

**3 HEAT**  
High Quality materials used throughout  
**\$6.50** each



*A Complete Line of Public Address Systems . . . hard to get radio parts . . . everything to meet your requirements.*

**RADIO PARTS COMPANY**

612 W. RANDOLPH ST., CHICAGO 6, ILLINOIS

*First Choice*

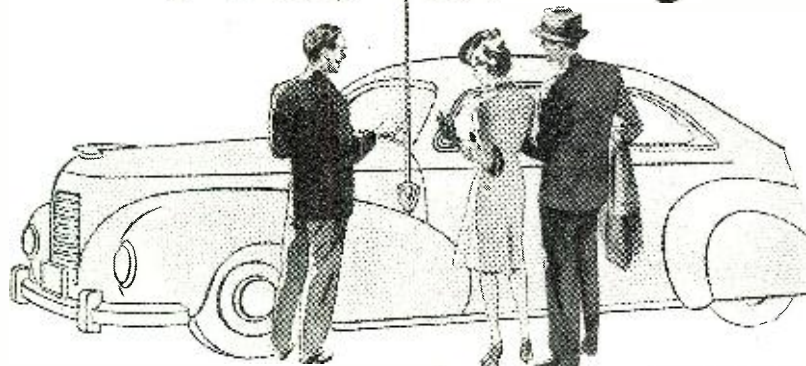

**... OF AMERICA'S AUTO DEALERS**

The same precision workmanship and the same fine quality mark Ward Antennas now as before the war. But now there are added reasons of new design and newly-engineered efficiency which will give Ward Antennas an even greater margin of preference with America's auto dealers. For extra profits that satisfied customers always bring, order Ward—world's finest antennas for car and home.



Buy Victory Bonds

**THE WARD PRODUCTS CORPORATION**  
1523 E. 45th St., Cleveland 3

**WARD**

*Antennas*

frequently falls short in maintaining a good signal from all sources of transmission without multiple images. The only present answer to this dilemma is dual installation, *i. e.*, two antenna arrangements must be used to bring in all video signals. In this respect, there may be occasions where three separate installations are necessary. This would, however, add additional cost to the installation.

A question which is quite prevalent in the minds of many television folk is the factor of *deadspots*, by which we mean areas which are incapable of reception. The question has recently been asked as to whether or not there are certain areas that are completely unable to receive a television signal. This point can be carried on endlessly without resolving an intelligent answer. It can be stated, however, that all external factors can be overcome so that reception is possible in any area, if the owner of the receiver is willing to pay maximum costs for installation and permission is given by neighboring landlords to mount antennas on their roofs.

Previous to undertaking the task of installation, the serviceman should consult signal strength transmitting charts which are made available by the station. In this way, he will find out just what sections are affected by what strength of the signal. Through this preliminary procedure, television installers could estimate the expected signal on a specific receiver from a predetermined station.

However, his expectations of a definite signal strength must be sobered by relevant, pertinent factors. Firstly, as it has been shown, the problem of location must be considered. In the second place, the understanding of just what is the sensitivity of certain receivers is important. The serviceman should honestly understand the capabilities of the receiver which he is installing.

Every receiver does not have the same sensitivity; it can usually be found that the higher-priced sets are more sensitive. The expectancy of a low-priced receiver should be understood and the owner should be made to realize under just what conditions he can expect good reception. The rule can well be made that cheaper receivers require a better installation and, therefore, higher costs should be expected.

To summarize, the reception of a video-signal in a highly urbanized area causes greater installation difficulty than in a sparsely populated section. These problems which affect proper reception can be solved but only at the expense of greater material and service costs, since very few points lend themselves to line-of-sight pick-up. Therefore, high installation costs must be paid by the owner of a television receiver which has to contend with physical barriers, a lengthy coaxial cable lead-in, and the lack of reception from all available stations.



# Must we go back?



The evolution of electronics will always remain a bright page in the history books of science. And the record has been significantly brilliant during the past four years when improvements and developments were advanced at a faster rate than normal. With the ending of the war, there may be a few who do not feel the urgency to progress at a similar pace . . . who will be willing to relax the rigid wartime standards. Or there may be those who do not too accurately gauge the temper of the consumer, now in a mood to anticipate only the best from an industry which has accomplished such miracles in the past few years.

Along with many other far-sighted producers, we here at Marion fully intend to maintain our wartime quality pattern, and to cooperate in every known way to provide even better products for a peaceful world. We endorse the postwar standardization program of the Army and Navy Electronics Standards Agency, and will continue to manufacture all Marion electrical indicating instruments in conformity with JAN specifications. Our customers have a right to expect nothing else.

It is important to note that continued adherence to the Electronics Standards Agency program need not result in increased costs, either to the manufacturer or the consumer . . . while it will definitely result in improved product performance wherever such standardized components are used.

We, the manufacturers, engineers, consumers of electronics, are part of a vital, daring, visionary industry. It is with this realization that we are faced with the responsibility of deciding, at this time, whether we can relax, or whether we shouldn't give as much to a world at peace as we gave to a world at war.

*Your comments will be welcomed.*



**MARION ELECTRICAL INSTRUMENT CO.**

MANCHESTER, NEW HAMPSHIRE

EXPORT DIVISION 458 BROADWAY - NEW YORK 13, N. Y., U. S. A.

CABLE ADDRESS: MORHANEX



Speed peacetime goods  
to market with...



**Clippard**

**Electro-Magnetic Windings  
and R. F. Coils**

The same personalized skill and service that helped us produce hundreds of thousands of components and sixteen separate types of test equipment for the Navy's V.T. proximity fuse can now help you produce better, sturdier, more salable products for civilian use. We're equipped to fulfill your Electro-Magnetic Winding, R.F. Coil, Sub-Assembly or special Test Instrument requirements with intelligence and dispatch. Send your specifications for quotes, TODAY!

**NEW! Laboratory-Type**

**ELECTRONIC  
Volt-Ohmmeter**

Incorporates features and accuracy of expensive custom-built laboratory equipment—yet priced within reach of all wanting the best. Low capacity, high impedance input. Balanced circuit. Wide Audio, H.F. and V.H.F. response. New small-diameter diode probe reaches difficult places with minimum lead length. Full scale sensitivity of 1 volt. Determines resistances from fraction of 1 ohm to 1000 megohms. Decibel scale for measuring audio gain. Sturdy oak case. Handy carrying handle. Write for details.



SPECIAL INSTRUMENTS FOR ELECTRICAL  
AND ELECTRONIC TESTING

ELECTRO MAGNETIC WINDINGS

R. F. COILS

SUB-ASSEMBLIES

**Clippard**  
INSTRUMENT  
LABORATORY  
1440 CHASE AVE. CINCINNATI 23, O.

# The Signal Corps ON-AND IN-THE AIR

By CLARK E. JACKSON

*Historical records of a highly mobile 3 kw. airborne radioteletype communications system.*



Interior of message-center plane, employed by the Signal Corps airborne radioteletype system in Japan. Left to right: radio operator, teletypist, and clerk.

**T**HE average radioman's prewar conception of a three-kilowatt radioteletype communications system, even on a small scale, included an extensive staff, banks of equipment housed in permanent locations, and

huge transmitting towers. The thought of making the entire system airborne, and able to land and send traffic over thousands of miles in 35 minutes, would have been considered fantastic.

Now the U. S. Army Signal Corps in the Pacific has made it a reality!

The airborne radio station was a natural development of the increasingly mobile communications provided for General MacArthur's headquarters.

First, in Australia, the U. S. Army Signal Corps installed high-powered radio stations aboard a special train for General MacArthur's headquarters. Amphibious operations took our radios to sea in special Signal Corps ships. Large transmitter and receiver sets mounted in trucks sped down the Luzon Valley with General MacArthur, carrying dependable mobile communications back to his main headquarters. The accent was on speed, mobility, and high power. Each time, the Signal Corps met the test.

Surrender terms were being discussed and plans to meet the change were formulated by Major General Spencer B. Akin, Chief Signal Officer in the Pacific. Remembering all too well the treachery we had encountered in the Pacific War, once we got



Interior of transmitter plane, showing 3 kw. radioteletype transmitter, frequency shifter FS 112A, and transmitter BC 610 (Hallicrafters HT4).



# Wilcox Type 996 C Transmitter

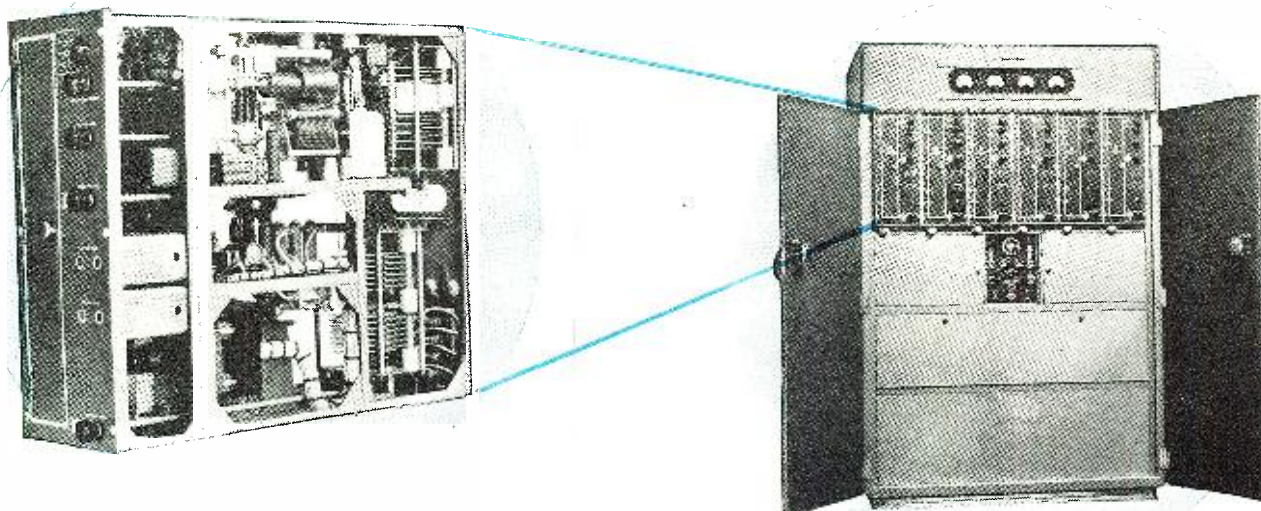

**REMOVABLE R. F. HEADS**—All radio frequency circuits are included in the 2-20 Mc. R. F. head shown above. All connections to the transmitter cabinet are by means of plugs and receptacles.

An expanded version of the now famous Wilcox Electric Co. Type 99A four channel transmitter, the 996C affords two additional communication channels and the option of dual plate power supplies for increased simultaneous channel operation and greater reliability.

The 996C Transmitter is designed particularly for aeronautical and other fixed services requiring multiple-frequency operation. Check these features for their application to your communication problems:

- ★ Six transmitting channels in the following frequency ranges:
  - 125-525 Kc. Low Frequency.
  - 2-20 Mc. Medium-High Frequency.
  - 100-160 Mc. Very-High Frequency.
  - (Other frequencies by special order.)
- ★ Simultaneous channel operation in the following maximum combinations:
  - 3 Channels telegraph.
  - 2 Channels telephone.
  - 1 Channel telephone, 2 Channels telegraph.
  - (Other combinations available with dual plate power supply option.)
- ★ Complete remote control by a single telephone pair per operator.
- ★ Carrier power—400 Watts plus.
- ★ Removable Radio Frequency Heads are your protection against frequency obsolescence.
- ★ Actual field tests, backed by thorough engineering research, are your guarantees for reliability.

*An inquiry on your letterhead outlining your requirements will bring you complete data.*



**WILCOX ELECTRIC COMPANY, INC.**

Manufacturers of Radio Equipment

Fourteenth and Chestnut

Kansas City, Missouri



# NEW SOLDERING GUN

THE SPEED IRON\*



Patent Applied For

100 Watts 115 Volts 60 Cycles

## Soldering Heat in 5 Seconds

Wherever you have a soldered joint in radio, electrical or electronic repair and service work, the Speed Iron will do the job faster and better.

The transformer principle gives high heat—in 5 seconds—after you press the trigger switch. Convenient to hold with a pistol grip handle, the compact dimensions of this new soldering tool permit you to get close to the

\*T.M. Reg. U. S. Pat. Off.

joint. The copper loop soldering tip permits working in tight spots. The heat is produced by the high current flowing through the soldering tip—permitting direct and fast transfer to the soldered connection.

If you want to save time on soldering jobs with a tool that is ready to use in 5 seconds, get a Speed Iron today. See your radio parts distributor or write direct.

## WELLER MFG. CO.

DEPT. RN-1 • EASTON, PA.

## Now an entirely new line!

Quality  
sound equipment  
by  
Newcomb

PRESENTING our newest line of amplifiers... they offer you greater excellence in sound reproduction than has ever before been available to the public address field. Designed and produced by an organization devoted exclusively, for more than seven years, to the perfection of fine sound equipment, they embody all the practical benefits of today's

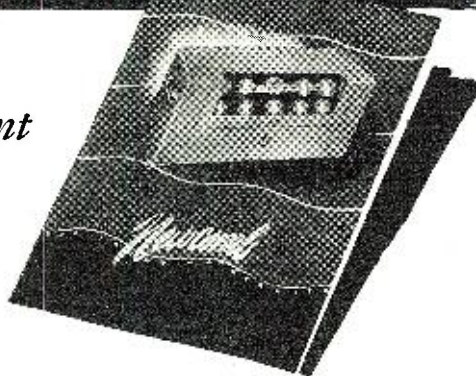

most advanced electronic achievements.

Send for the catalog... compare Newcomb with others... you'll find no other amplifier has so many advantages.

THE SOUND OF QUALITY

Newcomb  
AUDIO PRODUCTS CO.  
MANUFACTURERS

DEPT. F 2815 S. HILL STREET, LOS ANGELES 7, CALIFORNIA

into Japan, we had to stay, even if it was a last insane plunge at national suicide rather than peace the Japanese Empire sincerely wanted.

Communications back to Okinawa and Manila, that could handle the traffic and carry enough wallop in the signal strength to give reliable communications, had to be rapidly installed. This necessity gave birth to GHQ Airborne Radio Communications.

A plan was formulated to mount a three-kilowatt transmitter, using a two-tone system of radioteletype, which is much faster and more accurate than CW, in a C-46 cargo plane, employing frequency shifter FS-112-A. Also aboard the transmitter plane were the antennas and their accessories and a BC-610 with a whip antenna, the Army's adaptation of the *Hallcrafters HT-4*, as a standby, or in case General MacArthur chose to broadcast from the landing field.

Another C-46 carried two communications receivers and a teletypewriter set, a small, compact, complete message center, and two PE-75 2½ kw. gasoline generators, alternately used as power supplies for the receivers and teletype. Still another C-47 carried a 15-kw. diesel generator and drums of fuel.

Lieutenant F. Russel Hyde of Elmira, N. Y., twice winner of the Bronze Star and recipient of a field commission for his technical achievements, was assigned to design and supervise the installation. Army Airways Communications System furnished a dozen men and the necessary equipment. The project was tested and ready for operation three days after the idea was born. Men and officers worked twenty-four hours a day to accomplish the job.

The equipment was heavy and had to be installed so as not to vibrate in flight, and yet be situated so as to be operative from the plane.

A regular horizontal transmitting antenna requires an elaborate ground system or counterpoise for efficient operation. This takes considerable time, so the plane was used as a counterpoise. Transmitter and power supply planes were parked nose to nose and a 38-foot antenna was strung between them. In testing with a purposely faulty ground, three-inch sparks were drawn off the propellers as the current lobe was somewhere at its peak at that particular point. With a good ground, the spark gap was lost and danger of fire from the 100-octane gasoline was negligible. The receiving antennas were doublets, precut to operating frequencies. The transmitter and power planes were parked one-half mile from the receiver-message center plane to avoid interference.

The personnel aboard consisted of two officers and nine enlisted men to install and operate the station, with the plane crews helping rig the antennas. The Signal Corps enlisted personnel comprised four radio technicians, one powerman, and four message center specialists.



**MOST-OFTEN-NEEDED**

**A . . . A C . . . A N . . .**



**1942 4 OUT OF 5 DIAGRAMS YOU WILL EVER NEED**

Find radio faults quickly. Make the needed repairs in any radio in minutes instead of hours. Save time on every job. This large, inexpensive diagram manual has the circuit for every popular 1942 radio set. 4 out of 5 diagrams you will ever need are included.

**WITH ALIGNMENT DATA, PARTS LISTS**

Clearly printed circuits, alignment data, parts lists, service hints are the facts you need to speed up radio servicing. Repair radios quickly and properly—follow the factory instructions given in these manuals. 351 models of 40 largest manufacturers. 192 fact packed pages. Large size, 8½x11 in. Manual style binding. Postpaid. **\$2.00**

**POPULAR, LOW-PRICED DIAGRAM MANUALS**

**1941**

These easy-to-apply, inexpensive manuals will help you repair radios faster. This volume covers 1941 models, with alignment data, I.F. peaks, and replacement parts lists.

Compiled by M. N. Beitman, radio serviceman for many years, author and teacher. Be an expert in radio servicing; simplify your work. **\$2.00**  
192 pages, 8½x11 inches. Only



**1940**

Let this important manual give you over 80% of all 1940 circuits you will ever need, acquaint you with new developments, train you to service quickly and efficiently millions of sets. Data on F.M., portables, recording, etc. 417 models of 43 manufacturers. 208 large pages of helpful data. Net price **\$2.00**

**Most Popular Models Made By:**  
Philco, RCA, Zenith, Sears, GE, Emerson, Belmont Radio, Detroit, Fada, United Motors, Westinghouse, Arvin, Majestic, Stewart-Warner, Admiral, Delco, Stromberg-Carlson, Western-Auto, Sparton, Wards, Motorola, Gamble, and many others.

**1939**

Another handy manual of most-popular diagrams you need. Circuit data, hints and information are time-savers and money-makers for you. Let these diagram manuals guide you to easier service work. Why try to get along without helpful diagrams? Use this volume with 192 pages of diagrams of 39 makes. Order these manuals today. Price **\$2.00**

**1926-1938**

The most popular volume of the series. Will pay for itself with the time saved during the first day of use. Includes all the popular old timers. Save hours on every job. 427 diagrams of the most-serviced radios of this period, with parts lists and alignment information. 240 pages, 8½x11 inches. Sold with a money back guarantee. Price **\$2.50**



Compiled by M. N. Beitman, radio engineer, teacher, author, and serviceman.

**SAVE HOURS ON EVERY JOB**

Be ready to make repairs in minutes instead of hours. You will be called upon to fix hundreds of models listed in these easy-to-use manuals. Tackle each job with the needed help found in these service manuals. Greatest bargain in diagram books. Send your order today. Plan to use these manuals this week.

**Other Practical Radio Manuals**

**RADIO SERVICING COURSE**



Learn new speed-tricks of radio fault finding, case histories of common troubles, servicing short-cuts, extra profit ideas. Many large lessons on the use of regular test equipment, explanation of signal tracing, television to the minute, recording dope. Many active servicemen used this reduced price radio training for brush-up and study of new service methods. Reprinted in 1945 with new information on signal-tracing, television, visual alignment, P.A., photocells, and every other fact you must know to be more expert in your work. Complete, 22 lessons, size 8½ x 11 in. **\$2.50**  
Net.

**SIMPLIFIED RADIO SERVICING BY COMPARISON**



New, revolutionary different COMPARISON technique permits you to do expert work on all radio sets. Most repairs can be made without test equipment or with only a simple meter. Many point-to-point, cross-reference, circuit suggestions locate the faults instantly. Covers every radio set—new and old models. This new servicing technique presented in handy manual form, size 8½x11 inches. 76 pages. Over 1,000 practical service hints. 24 large, trouble-shooting blueprints. Charts for circuit analysis. 114 tests using a 5c resistor. **\$1.50**  
Net Price.

**PRACTICAL RADIO MATHEMATICS**

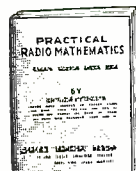

Introduces and explains the use of arithmetic and elementary algebra in connection with units, color code, meter scales, Ohm's Law, alternating currents, ohmmeter testing, wattage rating, series and parallel connections, capacity, inductance, mixed circuits, vacuum tubes, graphs, curves, the decibel, etc., etc., and has numerous examples. Net. **25c**

See Your Radio Jobber or Send Coupon



**NO RISK TRIAL ORDER COUPON**

SUPREME PUBLICATIONS, 9 S. Kedzie Ave., Chicago, ILL.

Ship the following manuals: (Money back guaranteed).  Radio Math  
 1942  1941  1940  1939  1926-1938  
 Radio Servicing Course.  Simplified Radio Servicing by Comparison  
 I am enclosing \$....., send postpaid.  
 Send C.O.D. I am enclosing \$..... deposit.

Name: .....

Address: .....



## Sensational METER BARGAINS

General Electric, Western Electric, Weston  
**WESTERN ELECTRIC—**  
BASIC MOVEMENT 0-1 MIL  
DC; SCALE MARKED 0-20  
KILOVOLT;  
DIAMETER 3 3/8".



No. 273....\$3.95

No. 274 G.E.-Weston 0-10  
Mil DC 2 1/2" Dia.....\$2.75  
No. 276 Gen. Electric 0-200  
Mil DC 2 1/2" Dia.....\$2.75

### EMBY SELENIUM RECTIFIERS

Type DS. Input 10 Volts A.C.  
Output 10 MA Continuous —  
Bridge Type. Full Wave.  
No. 231 List price.....\$3.75  
YOUR COST.....\$1.49

QUANTITY LIMITED

### 12" PM SPEAKERS

with 16 oz. MAGNET



Ideal for P.A. work or wherever high quality reproduction is a "must." ACT FAST! Quantity limited.

No. 275  
\$6.25

### METAL CASE BATH TUBE CONDENSERS—OIL-FILLED

These Condensers are offered at a fraction of their regular cost!

No. 125 .1 mfd 600 Volt...19c

No. 126 .25 mfd 600 Volt..19c

No. 129 .5 mfd 600 Volt...24c

No. 120 Dual .1-.1 Mfd 600

Volt.....29c

### CARBON RESISTORS

Best Quality Insulated 1/2 Watt  
All 5% or 10% Tolerance. In the following sizes only:—

#### OHMS

300 6,000 20,000

500 8,000 1 Meg

2,000 20,000

3,000 30,000

Sold in quantities of 100 only.

May be assorted.

No. 277.....\$2.95 per 100

Specify Ohmage

Write DEPT. A4 for FREE Catalog

listing. All parts immediately deliverable!

**RADIONIC  
EQUIPMENT CO.**  
"Chancellor Radio"  
170 NASSAU ST., N. Y. 7, N. Y.

Cable Address:  
"CHANSLOR"

The unit took off from Nielson Field, outside Manila, on the morning of August 25th. Weather conditions forced them to stay overnight at Laog, Northern Luzon. They arrived at noon, August 26th, on Yontan strip, Okinawa, and flew to Motabu strip in the afternoon.

The transmitter plane developed trouble in the hydraulic system after taking off at Manila. The landing gear was defective and the pilot had to bounce the plane against the runway at flying speed to bring the wheels up into place. It would have taken three or four days to remove the equipment and put it in another plane. They couldn't fly with the gear down because the drag would have slowed them so they wouldn't have had enough gas to make the next strip.

Each time they took off, the nerve-straining experience of diving, full speed at the runway, bouncing and zooming up into the air was repeated.

After final instructions and briefing on behavior in case of incidents, the team took off for Atsugi Airport, outside Yokohama, at 4 a.m., August 28th. Again, the transmitter plane buzzed the strip and bounced its landing gear into place.

On the way up, men checked and adjusted their equipment. They were to be among the very first into Japan.

Shortly after 9 a.m. on the 28th, the strip was sighted and the Airborne Radio Station jockeyed into the landing circle. They were the 3rd, 4th, and 5th American planes to land. Tension was relieved when a truck came roaring out from the side of a hangar with a sign on its back in large letters, *Follow me*, much as you'd find on the back of an American jeep at one of our strips. Labor details had been provided in advance by the Japanese

to move the planes into position. Positions had been pre-picked and the planes taxied over to them on the side of the runway.

The Japanese were saluting, but made it a point to stay out of the way of the Yanks. After the door of the planes opened, one man started from the transmitter plane with a reel of field wire for the remote keying lines and passed another coming from the receiver and message center plane one-half mile away with the telephone line.

Power and transmitter planes were parked nose to nose and the power cables laid. The planes were electrically bonded and grounded. Within 34 minutes, one channel of radio teletype was in communication with Manila to establish a record for such a circuit.

During the first four days of operation, more than 200,000 groups of traffic were cleared through the system.

—30—

### Sound Reproducer

(Continued from page 39)

consideration to the combinational tones in music, and it is precisely these qualities that are brought out with astounding realism. Actual tests were made of the sound values, and it has been proved beyond doubt that there is no predominance of higher or lower frequency response from any point within the enclosure, but an absolute pure blending of the tonal response from the various units when measurements are taken from a reasonable distance from the sound source.

In recordings such as the *Sextet from Lucia*, the notable features are that all the voices stand out singularly and yet in harmony and in good blend-

Efforts of the German army to duplicate American radio equipment were successful in the case of the 9-tube receiver (right) which Jack Ivers, chief electrical engineer for the National Radio Company, is here testing. The set, in electrical and mechanical design, was pronounced a "dead ringer" for National's HRO receiver (left), which was supplied to the Allied forces in vast quantities. Craftsmanship and materials used, however, were said to have been "much inferior."

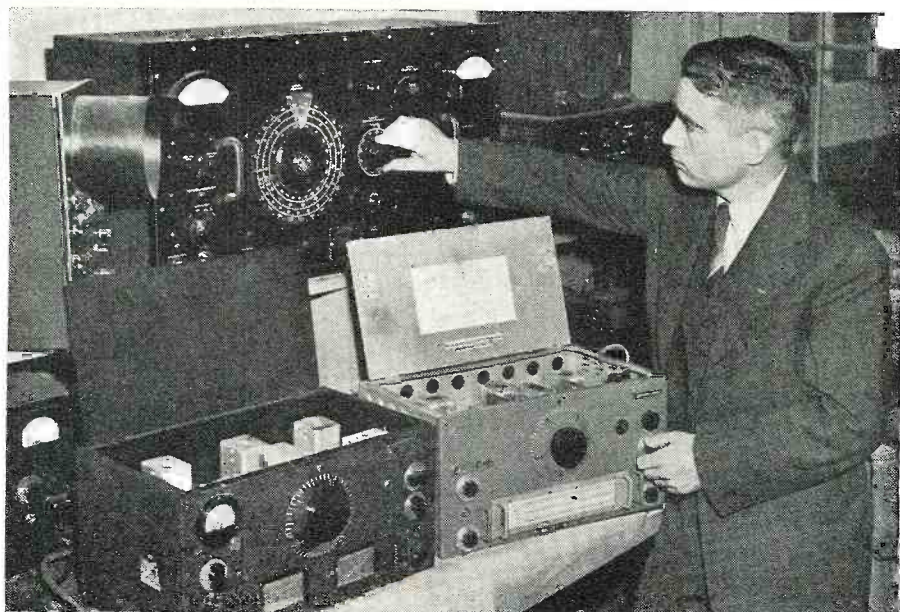



# MORE POWER OUTPUT **BUT** LESS BATTERY DRAIN WITH HYTRON INSTANT-HEATING BEAM TETRODES

**ZERO STAND-BY CURRENT** Thoriated tungsten filaments of the Hytron 2E25, HY69, and HY1269 permit simultaneous application of all potentials. During stand-by, no precious filament current is drawn from the battery. Especially with the larger tube complements of FM transmitters, is conservation of battery power mandatory.

**MORE OUTPUT—GREATER RANGE** Only 4% of the current required for cathode types, is necessary to operate the instant-heating 2E25, HY69, and HY1269. (See table below.) Even in a mobile FM transmitter, 100 watts output is practicable. Imagine the advantages of such increased output in police, marine, or other mobile equipment.

**SPARES PROBLEM SIMPLIFIED** Using the 2E25, HY69, and HY1269, you take full advantage of the beam tetrode's versatility. The 2E25, for example, can power a whole transmitter—AF and RF—AM or FM. If more output is required, HY69's or HY1269's in push-pull still confine the spares complement to only two types.

**ADVANTAGES OVER CATHODE TYPES** Yes, the 2E25, HY69, and HY1269 cost more than cathode types. But they are worth it. Not only are they easier on the battery, and permit larger outputs, but they are designed, built, and tested for transmitting. Some advantages are: centering of filament potential at 6.0 volts, r.f. shielding to eliminate the necessity for neutralization, low-loss insulation throughout, plate connection to top cap, and rugged construction.

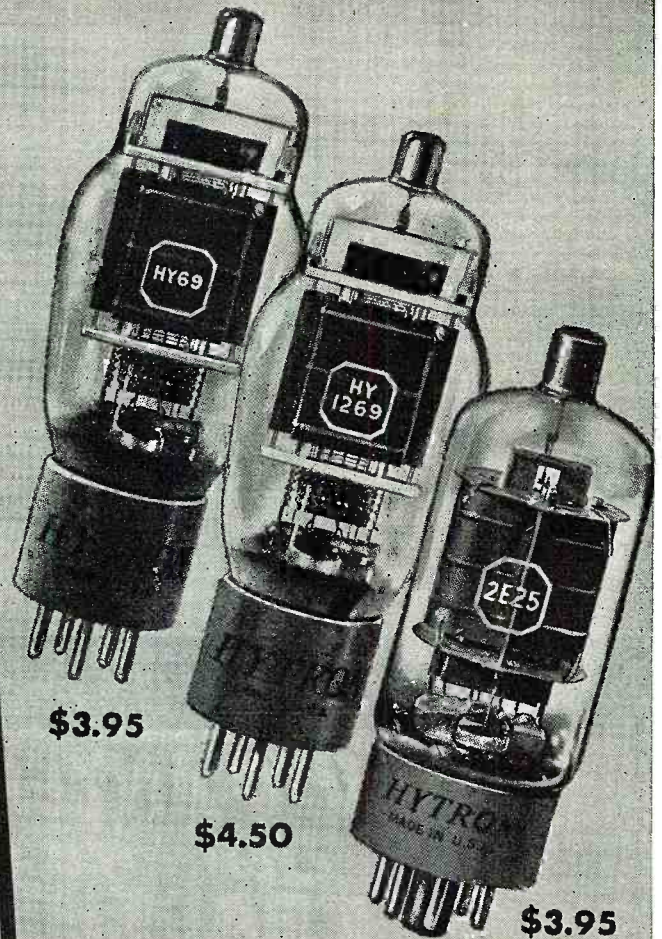

\$3.95

\$4.50

\$3.95

## BATTERY DRAIN OF A CONVENTIONAL TRANSMITTER AND KAAR FM-50X EQUIPPED WITH HYTRON INSTANT-HEATING TUBES

	Conventional 30 watt	KAAR FM-50X - 50 watt
AMPERE HOURS:	0 10 20 30 40 50 60 70	
STANDBY DRAIN 24 HOUR PERIOD	55.2 AMPERE HOURS	0.0 AMP. HRS.—YET READY TO TALK INSTANTLY!
AVERAGE TOTAL BATTERY DRAIN 24 HOUR PERIOD	56.8 AMPERE HOURS	2.2 AMPERE HOURS

This chart, prepared by Kaar Engineering Co., is based on typical metropolitan police use of 140 radiotelephone-equipped cars operating three shifts in a city of 600,000 population. The 24-hour survey included 904 messages originated by cars and 932 messages acknowledged by cars. Transmissions averaged: 13 per car, 15 seconds in length, and 3 minutes 15 seconds transmitting time.

## ABBREVIATED DATA HYTRON INSTANT-HEATING BEAM TETRODES

Characteristic	2E25	HY69	HY1269
Filament Potential (volts)	6.0	6.0	6/12
Filament Current (amps.)	0.8	1.6	3.2/1.6
Plate Potential (max. volts)	450	600	750
Plate Current (max. ma.)	75	100	120
Plate Dissipation (max. watts)	15	30	30
Grid-to-Plate Capacitance (mmfd.)	0.15	0.25	0.25
Maximum Seated Height (inches)	3 5/8	5 1/4	5 1/4
Maximum Diameter (inches)	1 7/16	2 1/16	2 1/16
Class C Power Output (watts)	24	42	63
Class C Driving Power (watts)	Less than one watt		



OLDEST MANUFACTURER SPECIALIZING IN RADIO RECEIVING TUBES

# HYTRON

RADIO AND ELECTRONICS CORP.



MAIN OFFICE: SALEM, MASSACHUSETTS



# SMASH!

## VALUES! SAVE MONEY ON HARD-TO-GET RADIO PARTS

### FIRST LINE BRANDS ELECTROLYTIC CAPACITORS

Cap.	DC Voltage	Net Price	Net Price for 10
100	25	\$ .43	\$3.90
10	50	.28	2.50
20	150	.37	3.40
20-20*	150	.61	5.60
50	150	.49	4.60
10	450	.51	4.50
10-10*	450	.74	6.90

### TUBULAR PAPER CAPACITORS

Cap.	Net Price	Net Price 24 or more
MFD	Price	
.001	\$.09	\$.08
.002	.09	.08
.005	.09	.08
.01	.09	.08
.02	.09	.08
.05	.11	.10
.1	.13	.12
.25	.18	.16

Toggle Switch—STDT— $\frac{3}{4}$ " Stem. Each .37c  
 Mercury Coil Dope—6 oz. can—Each .69c  
 Aerial Wire—7 strand-50 ft. roll. Each .27c  
 10 for \$2.49  
 Aerial Kits—Includes stranded copper wire, ground clamps, porcelain insulators, etc. Each 99c

### SPECIAL

Universal Velocity Microphone—40,000 Imp. 25 ft. cable, each . . . \$14.70  
 Army Headphone  
 DC Resistance—17000 Ohms . . . 2.95  
 Simpson Multi-range Output Meter. Model 427 . . . 10.95  
 Weston  $3\frac{1}{2}$ " Rd. Meter—Model 476-0-150V AC . . . 4.95  
 Mercury Model Z Selenium Rectifier type  $1\frac{1}{2}$  V and 90V Battery Eliminator . . . 8.65  
 Dual Tr. I.F. Input or Output Transformers—455 KC. . . . . Each 55c

Philmore Headphones—Single 1000 Ohms. . \$1.29  
 Double 2000 Ohms . . . 1.89  
 Knob Kit—50 De Luxe Plastic Set Screw Knobs 4.35  
 Volume Controls—10M, 25M, 500M, 1 Meg, 2 Meg—All with switch 2 to  $2\frac{1}{2}$ " standard shaft. Each, 69c . . . 10 for 6.75  
 Single Cond. Rubber Mike Cable. Foot . . . 7c  
 Per 100 ft. . . . . 5.95  
 Shielded Phono Wire. 50 ft. coil . . . . . 99c  
 100 ft. . . . . 1.79  
 Spaghetti Kits, 25-3 ft. lengths assorted sizes and colors . . . . . 1.95  
 Antenna Hanks. 25 ft. each . . . . . 18c

Order direct from this ad—or write Dept. RN-12 TODAY for BIG FREE Catalog of HARD TO GET RADIO PARTS AVAILABLE NOW!  
 Our Terms are Cash. All C.O.D. orders must be accompanied with a deposit of 25% or more. We pay all shipping charges only on prepaid orders of \$25.00 or more.

CENTRALLY LOCATED TO SERVE THE NATION  
 NATIONAL ELECTRONIC SUPPLY  
 622 WEST KINZIE STREET • CHICAGO 10, ILLINOIS

ing with the rest of the musical qualities. In the *Hungarian Rhapsody #2*, the magnificent chords and the massiveness is reproduced with brilliant results and without distortion.

From the practical aspect the resonator not only offers a superior acoustical result, but also simplifies a sound installation in large auditoriums or theaters, as it requires only one outlet for each unit, and since the distribution of sound may be considered perfect, it can readily replace an average installation where 25 to 50 loudspeaker units are generally employed toward the same end.

In view of the structural simplicity, there is naturally little technical information necessary; the illustrations may be considered self-explanatory.

-30-

### International Short-Wave

(Continued from page 86)

burg, since blanks are printed on the card for writing in station call, frequency, wavelength, and other information.

According to the station list sent, frequencies and schedules for the fall and winter are:

Johannesburg 3, 3.450006 mcs., 10:30 or 11:30 a.m.-4 p.m.; 4.895, not in use at present; 6.007289, 11:45 p.m.-1:30 a.m. and 9-11:30 a.m.; 9.523142, 3:15-7 a.m.; 11.710 and 19.046164, not in use at present

Johannesburg 4, 6.094776, 11:45 p.m.-1:30 a.m., 9-11:30 a.m., and 10:30 or 11:30 a.m.-4 p.m.; 9.902525, not in use at present; 10.539562, 3:15-7 a.m.

Johannesburg 5, 4.381744, not in use at present.

Capetown 3, 5.883966, 11:45 p.m.-1:30 a.m. and 10:30 or 11:30 a.m.-4 p.m.; 9.608469, 3:15-7 a.m. and 9-10:30 a.m.

Durban 3, 6.169747, not in use at present.

Pietermaritzburg 2, 4.876206, not in use at present.

Although officially listed as *off the air at present*, the Durban and Pietermaritzburg transmitters are reported heard irregularly, particularly in Australia and New Zealand; Durban on 6.170 is reported from the West Coast by Balbi, 12:45-1:30 a.m., off Saturdays.

### NEW

The Milan, Italy, transmitter has returned to the air relaying Milan medium-wave, heard 2-6 p.m. on 9.635; frequency varies. A station believed to be Milan has been heard recently late afternoons on 6.400, formerly a Milan frequency.

HAT4, 9.125, Budapest, Hungary, has been reported as heard on CW at 9:15 p.m.; thus far no voice broadcasting has been reported.

A Dutch phone circuit on 18.220 was heard recently opening at 7 a.m. with "PCQ, Amsterdam, calling New York." The broadcast relay was heard in dual very slightly higher but not separable.

### RADIO NEWS

# AUTO ANTENNAS

*Designed for*  
**LEADERSHIP**

Leaders in the auto antenna field for over a decade, JFD offers for prompt shipment auto antennas with these advantages:

1. Seamless Admiralty Brass Tubing
2. High-Polished Chromium Plating
3. Stainless Steel "Snap Back" Top Rod
4. Heavily Insulated Shielded Loom Lead
5. 100% Low Loss Construction

**Eight Fast Selling Sizes and Types**

Write for FREE literature # 344

**J. F. D. Manufacturing Co.**  
 4111 Ft. Hamilton Parkway,  
 Brooklyn 19, N. Y.





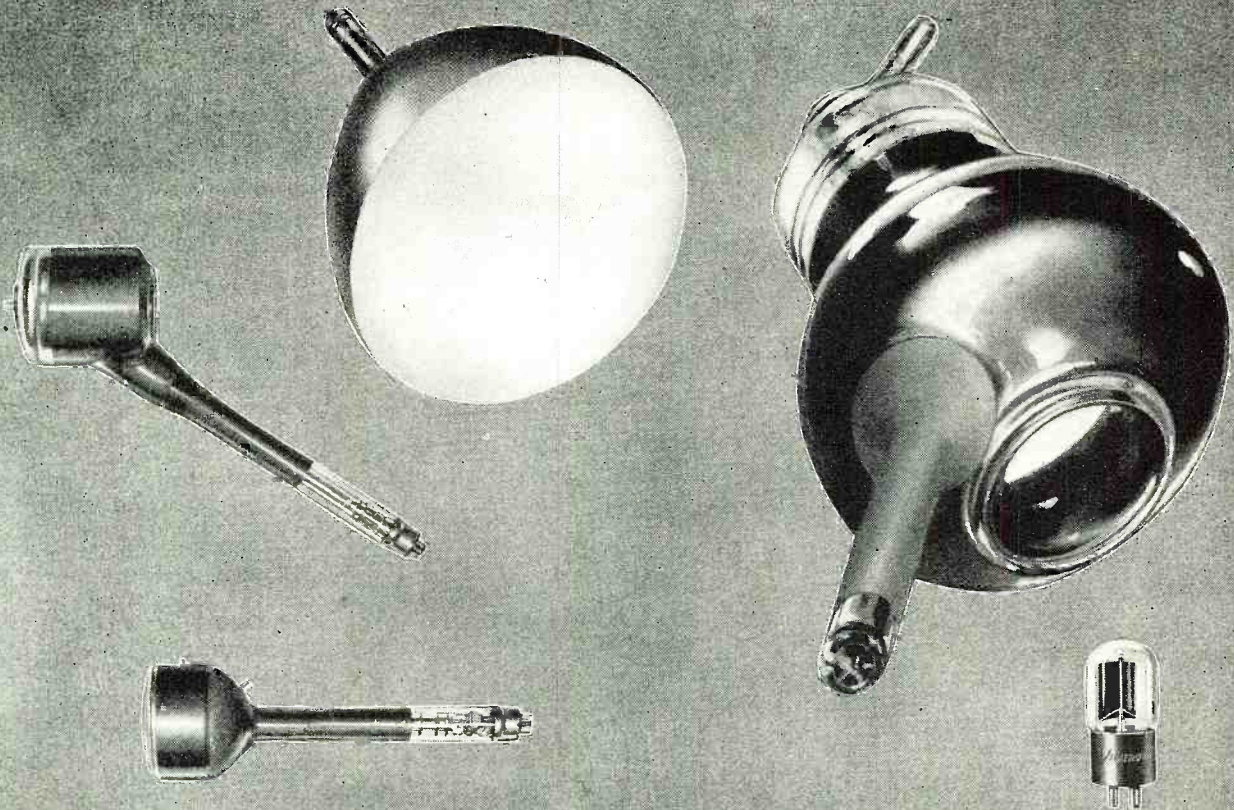

# VISITRON

## Television Tubes

by

*Visitron* is not a new name in tubes. *Visitron* is Rauland's name for all electronic tubes made in the Rauland Tube Division. It is the mark of the advanced *Rauland* Television thinking and planning based upon a pioneering experience second to none. *Rauland Visitron* tubes for direct-viewing for the home and projection for the home and theatre are ready to take their places in the new era of Television entertainment now unfolding before us.

To be sure of your tube, be sure it's "*Visitron*."

RADIO • RADAR • SOUND

# Rauland

COMMUNICATIONS • TELEVISION

*Electroneering is our business*

THE RAULAND CORPORATION • CHICAGO 41, ILLINOIS

January, 1946

101



**N**ow  
**Bud metal**  
**wall type**  
**speaker cabinets**  
*with superior*  
*tonal qualities*



Reproduction equal to the finest wood housings — that is what you find in the new BUD metal wall-type speaker cases. Now offered after months of research and testing by BUD engineers, this new line of wall-type speaker cases is truly outstanding for its fidelity of tone reproduction. Modernity of design and ease of installation are other features which place these speaker cases far ahead of anything on the market today. Made in sizes to house 4" to 12" speakers . . . available for immediate delivery.

**Chokes, Coils, and Condensers**  
to meet  
your needs

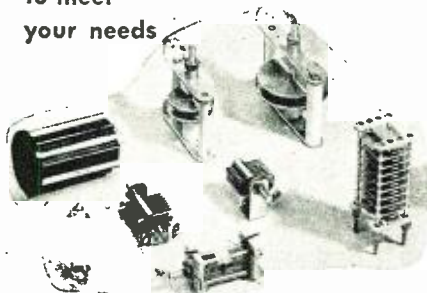

BUD makes an outstanding line of chokes, coils, condensers and other radio and electronic parts — engineered and tested for superior performance. You assure yourself of the latest developments in the field when you specify BUD. Get acquainted by writing for the free new 60-page BUD catalog.



**BUD RADIO, INC.**  
CLEVELAND 3, OHIO

Transmission runs as late as 2:30 p.m.; announcements have been heard in English and Dutch with a time signal each hour. Operator said they hoped to have a night transmission soon on a lower frequency. Another report indicates this station is carrying the Home Service, with extremely strong signals, 6:50 a.m.-3 p.m., using a loud dishpan-like gong. This station is list-as PCQ, Kootwijk, Holland.

Petropavlovsk, 6.070, U.S.S.R., is heard daily, 7:40-8:15 a.m., relaying Moscow's English radiation to North America; also Sundays, 12:30-1:30 a.m. with domestic programs in Russian. (*Balbi*)

A station at Batum (Georgian U.S.S.R.), 6.485, is reported coming on at 10:30 p.m. with a Turkish transmission; sign-off at 10:50 or 10:55 p.m.; signal strength fair, but CW interference is severe.

A new Soviet frequency of 11.918, probably Moscow, has been heard signing on at 10 p.m. with poor signal strength.

A third frequency is being heard on the 12 midnight-1 a.m. broadcast from Lourenco Marques, Mozambique, 15.380. Call letters have not been learned, but are probably CR7BG. The 5.860 and 9.580 frequencies of Radio Mozambique have been reported recently as very weak.

The station on 7.095, heard 5-5:35 p.m. and previously believed to be Radio Funchal, Madeira, has recently been identified as Radio Bissau at Bissau, Portuguese Guinea.

Now apparently under Chinese control, Taihoku, Formosa, 9.695, is heard 7:30-9:20 a.m., with a relay of English news from Chungking's XGOY at 9 a.m.; call letters of XUZE or XUCE were heard. (*Dilg*)

The call letters of the AFRS Tokyo station on 9.605 and 7.550 (best heard) are WVTR; six stations in Japan relay this station; schedule is midnight-9 a.m. sign-off, with news at 4 and 8 a.m. JVT, 6.750, JLS, 9.655, and JVP (*Jiggs-Victor-Peter*), 7.510, are reported in parallel to the U.S. networks. JLU2, 9.625, has not been reported recently to the networks. JVU3, 11.897, is reported heard carrying Home Service around midnight; Home Service over JLR, 6.015, is reported, 5-8:30 a.m.

Seoul, also known as Keijo, Korea, is now under U.S. control; heard as early as 6:15 a.m. with a Korean program; at 8-8:30 a.m. carries an American program, such as Kay Kayser's *College of Musical Knowledge*. Sign-off is 8:30 a.m. (*Dilg*)

Dilg and Balbi report an *Indonesian Republican* transmitter on 6.720, from around 5:30 to 7:30 a.m.; was first heard to fade-out at 9:30 a.m. Announces as "The Voice of Free Indonesia," and the transmitter is presumed to be PMH, Bandoeng, Java. Has been heard with messages to persons in England asking support for the "Indonesian Republic." American recordings have been heard. Signal fluctuates considerably. Mentioned a

dual station, probably referring to JANS. JANS, 12.275, and JBC, 18.135, Batavia, Java, are also heard, still using Japanese call letters.

Mexican amateurs are reported now being heard in the 40-meter band; strongest reported is XE1A, 7.050, Mexico City.

*The Voice of the U.S. Army in Austria* is a new Forces station at Salzburg, Austria, heard 12:30-2:30 a.m. and 4 p.m. (fade-in) to 5:30 p.m. sign-off on 7.238. The announced frequency is 7.220, with medium-wave stations at Salzburg and Linz also announced; call letters are KOFA.

*Radio Ljubljana* at Ljubljana, Yugoslavia, is reported with weak signals from around midnight to 2 a.m. fade-out and again in the afternoon to sign-off at 5 p.m., frequency of 6.505, with the Slovene language being used.

A new station at Philipsburg, St. Martin Islands, Netherlands West Indies, is reported irregularly testing and calling Curacao; good signal strength; heard at 1 p.m. on 9.065 and at 8:30 a.m. on 11.900.

WXFD, 16.025, believed to be in Aleutians, heard on this new frequency contacting WVD.

ZAA, 7.850, Tirana, Albania, is reported returned to the air on its old frequency, heard to sign-off at 2:40 p.m.

From the *ABC Weekly* (Australia) of September 29, 1945, comes the following details about Singapore Radio: British Military Administration in Malaya broadcasts daily from 11:30 p.m. to 10:30 a.m. The program is usually in English, with news at 11:30 p.m. and music, followed by a Malayan session from 12:30 a.m. to 1:30 a.m. Singapore returns to the air at 2:30 a.m. with 30 minutes of music, followed by POW names at 3, 4, and 5 a.m. News is read at 3:30 a.m. and 5:30 a.m. A further Malayan program is broadcast from 6:30 a.m. to 8:30 a.m. in Oriental languages. English is resumed between 8:30 a.m. and 9:30 a.m. Commentaries for the BBC are normally broadcast at 9 a.m. From 9:45 a.m. to 10:30 a.m. there are broadcasts in Oriental languages. Reception conditions are good, and by choosing the frequency no difficulty should be experienced in dialing Singapore. On 15.360 is heard 11:30 p.m.-1:30 a.m., and again 2:30 a.m.-5:15 a.m., being very clear in the latter period; 11.860 is normally strong from about 3:30 a.m. to closing time at 10:30 a.m.; 9.555 is particularly strong from 5:30 a.m., and 7.220 is reasonably good from about 6 a.m., but is subject to interference at times.

\* \* \*

**CHANGES**

Prague, Czechoslovakia, has dropped to 9.505 frequency for an announced frequency of 6.030, with the call of OLR2B. It is actually heard on 6.037, audible in the East, 3-5:15 p.m. sign-off. The 11.840 frequency is reported heard to 10 a.m. sign-off.

*Radio Seu*, Madrid, Spain, has again

**RADIO NEWS**



# WE ARE PLEASED TO ANNOUNCE

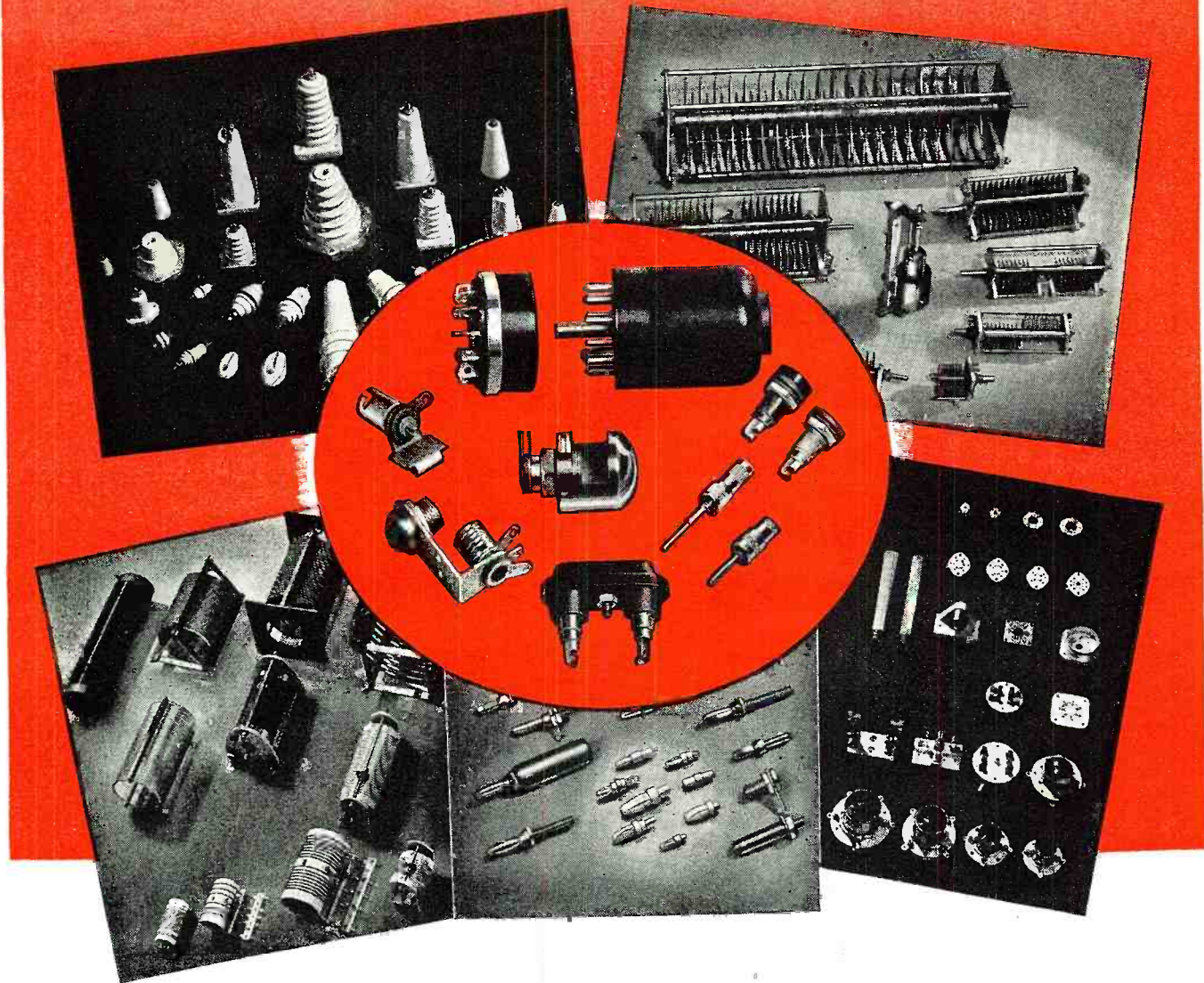

We are pleased to announce that the cable connectors, pilot light assemblies, tip plugs and tip jacks, former Mallory-Yaxley products, so highly regarded by the electronic industry for many years, will be manufactured and sold in the future solely by Johnson.

The wide acceptance and unquestioned quality of these products make them fitting additions to the Johnson line of plugs, jacks,

inductors, insulators, variable condensers and tube sockets.

All tools, inventory and manufacturing rights for these products have been acquired from P. R. Mallory & Company, Inc. Orders should specify the Mallory catalog numbers until these items can be incorporated in the Johnson catalog.

Write us, if you have a special problem involving any of these items.

Johnson products are stocked by leading radio-electronic parts jobbers.

Write for General Products Catalog 968-Z

**E. F. JOHNSON COMPANY • WASECA • MINNESOTA**  
January, 1946

## JOHNSON

*a famous name in Radio*





# HENRY RADIO

## is delivering RECEIVERS

We are delivering  
the following models:

National NC-240-C, less speaker . . .	225.00
National One-Ten . . .	56.10
National HRO Sr. . .	197.70
Hammarlund HQ-129X, less speaker . . .	129.00
Hammarlund Super Pro with speaker . . .	318.00
Hallicrafters EC-1A . .	29.50
Hallicrafters S20R . .	60.00
Hallicrafters S22R . .	74.50
Hallicrafters S39 . . .	110.00
Hallicrafters SX-25 . .	94.50
Hallicrafters SX-28A . .	223.00
Hallicrafters S36A . .	415.00
RME-45 with Xtal, 5 Meter, speaker . . . . .	166.00

Mail, phone, or wire your order. Demand may exceed supply for a few months. Reserve your receiver early. No priority required. No restrictions. You can send \$5.00 and pay balance C.O.D. You can trade in your receiver. You can buy on terms. Write for full information. Tell us your wishes. We will help you get the best receiver for your use and will see that you are 100% satisfied. We also have a complete stock of amateur parts, transmitters, etc. Send to us for any amateur apparatus in any catalog or advertisement at the lowest prices shown. Your inquiries welcomed.

# HENRY RADIO

BUTLER, MISSOURI AND  
LOS ANGELES 25, CALIF.

"WORLD'S LARGEST DISTRIBUTORS  
OF SHORT WAVE RECEIVERS"

104

shifted frequency, now heard on 7.135 regularly, same schedule.

Algiers has discontinued the 9.610 frequency, 1:30-6 p.m., and is now heard on 6.025, with bad QRM from Rome on 6.025. Another Algiers transmitter is still on 6.040 at the same time.

In November, VLC2, 9.680, *Radio Australia*, replaced VLC5, 9.540, to eastern North America, 8-8:45 a.m. daily; excellent signals are reported throughout the United States and Canada. Newscasts remain at 8:01 and 8:35 a.m. Within a few days of the change, *Radio Australia* was back on 9.540 for this transmission; it is suggested that DXers try either channel until the ABC settles on a definite frequency for this East Coast beam.

Schedules of the short-wave relays of the ABC domestic programs from Australia are reported as:

Brisbane—VLQ, 7.240, 3-7:10 p.m.; VLQ2, 7.215, 2:30-8:30 a.m.; VLQ3, 9.660, 8:45 p.m.-2:15 a.m. Perth—VLW3, 11.830, 10:40 p.m.-5:15 a.m.; VLW7, 9.520, 5:30-10:30 a.m. and 5-9:45 p.m. VLQ stations use 10,000 watts, while VLW's use 2000 watts. Most of these transmitters send good to excellent signals to the U.S., especially mornings, with VLQ2, VLW7, and VLQ3 being heard best here in the East.

ZBW, Hongkong, China, has been drifting; latest report is that ZBW is back on 9.470, heard 5:45-8:30 a.m., English from 7 a.m., news at 7, 8 a.m., weak signals. (*Balbi*)

Delhi on 7.210 has been carrying a Troops program, 8-9:30 a.m. The Forces program heard for two weeks at 7:30 p.m. now opens at 8:30 p.m. on a frequency of 6.190; a 61-meter band station (4.860) is also announced. The morning transmission in the 49-meter band is now heard over 6.010 instead of former 6.060. (*Dilg, Balbi*)

The new schedule of *Radio Saigon*, Indo-China, 11.780 and 4.810, in parallel, is 10:30-11:45 p.m., with news at 11:15 p.m.; and 2-8 a.m., with news at 5:15 a.m. Evidently, Saigon is now on Summer Time, 8 hours ahead of GMT and 13 hours ahead of EST.

Macau (commonly listed at "Macao"), Portuguese China, 7.530, is reported to sign off at 9:57 a.m.; carries a Chinese program from 9 a.m.; heard as early as 6 a.m. Balbi lists Macau as heard 4-9 a.m., and irregularly to 10 a.m., in Portuguese, Chinese, and English, with English news at 7:15 a.m. A detailed reception log received from Dilg on the Macau transmission of November 1, 1945, indicates that English news was read by a woman at 7:43 a.m.; this news was believed to be a pick-up from Shanghai. Dilg comments: "Macau does not seem to have any program continuity, or maybe each day is different. If so, English must be on Sunday as I have heard them play a number of American recordings on that day and give the titles in English; have also heard Chinese early. At sign-off on November 1, two frequencies were given, but

interference made the announcement unintelligible. Uses chime signal, usually 3 sets, and plays many musical recordings, particularly in European style."

FK8AA, 6.208, Noumea, New Caledonia, is reported heard 7-8 p.m., 2:30-4 a.m., and 4:30-5 a.m. This station uses 80 watts power, and verifies from Service de l'Information, French Government Office, Noumea, New Caledonia.

HI2A, Dominican Republic, is now on 7.085, identifies as *Broadcasting Nacional* and *La Voz de la Reeleccion*. The Dominican on 12.490 is reported to be a harmonic of HI1N, 6.245, relaying HIN.

XEWV, Mexico City, has dropped the 9.500 frequency in favor of 15.160, 8 a.m.-7:15 p.m., but the 9.500 frequency is still in use after 7:30 p.m. and to 2 a.m. sign-off.

YVKC, 9.640, Caracas, Venezuela, is now being heard at 12-4 p.m., approximately, and irregularly a few hours earlier.

The Azores changed time on October 28; schedules on 4.040 and 11.090 were advanced one hour; Ponta Delgada on 11.090 is now scheduled 3-4 p.m. Portugal, also affected, is now heard over CSW7, 9.740, 7-8 p.m.; before time change, CSW, 6.370, Lisbon, signed off at 6 p.m.

Balbi lists schedules of *Radio Rangoon* as 8:30-10 a.m. on 11.86, in Burmese, weak to fair; and 6:30-8:15 a.m. on 6.04, in Burmese, fair; the 11.860 transmitter has English news at 8:45 and 9:45 a.m. The URDXC, however, lists latest Rangoon schedules as 8:15-9 p.m., 1:15-2 a.m., 6:45-8:15 a.m. on 6.04, with English news at 8:30 p.m. and 1:15 a.m.; and 10 p.m.-1 a.m., 2:15-3 a.m., 8:30-10 a.m. on 11.860, with English news at 10:45 p.m., 2:30, 8:30, and 9:55 a.m.; the morning transmissions are reported as heard to the East coast. Still announce address as Headquarters Radio, Southeast Asia Command, Rangoon, Burma; want reports of reception.

The evening radiation from Lahti, Finland, 7:15-7:45 p.m., is reported heard in the East over both OIX2, 9.495, and OIX4, 15.190.

Luxemburg 2 returned to 6.020 on October 1 and is now scheduled 12 midnight-3 a.m., 5-8:30 a.m., and 12 noon-6 p.m.

Turkey is now on standard time, making broadcasts one hour later in the U.S., or the same clock time as before the September 30 time change in this country.

Although Moscow schedules and frequencies are constantly changing, best data received recently follows: 6:20-7:45 a.m. on 9.480, 11.630, 11.830, 15.750; 7:45-8:15 a.m., 6.070, 9.480, 9.565, 11.630, 11.750, 11.830, 12.110, 15.750; 11-11:25 a.m., 9.480, 11.830, 15.750; 6:20-7:28 p.m., 6.028, 6.770, 7.300, 7.360, 11.885, 15.230; 7:30-9:30 p.m., 6.028, 7.300, 7.360. Moscow has dropped the 11.878 and 9.713 frequencies in the nightly transmission to Latin America; now using 6.980, 7.210, and 7.430.

RADIO NEWS



# Reconversion Problems?

BREEZE is a Reservoir of Manufacturing Skills and Facilities

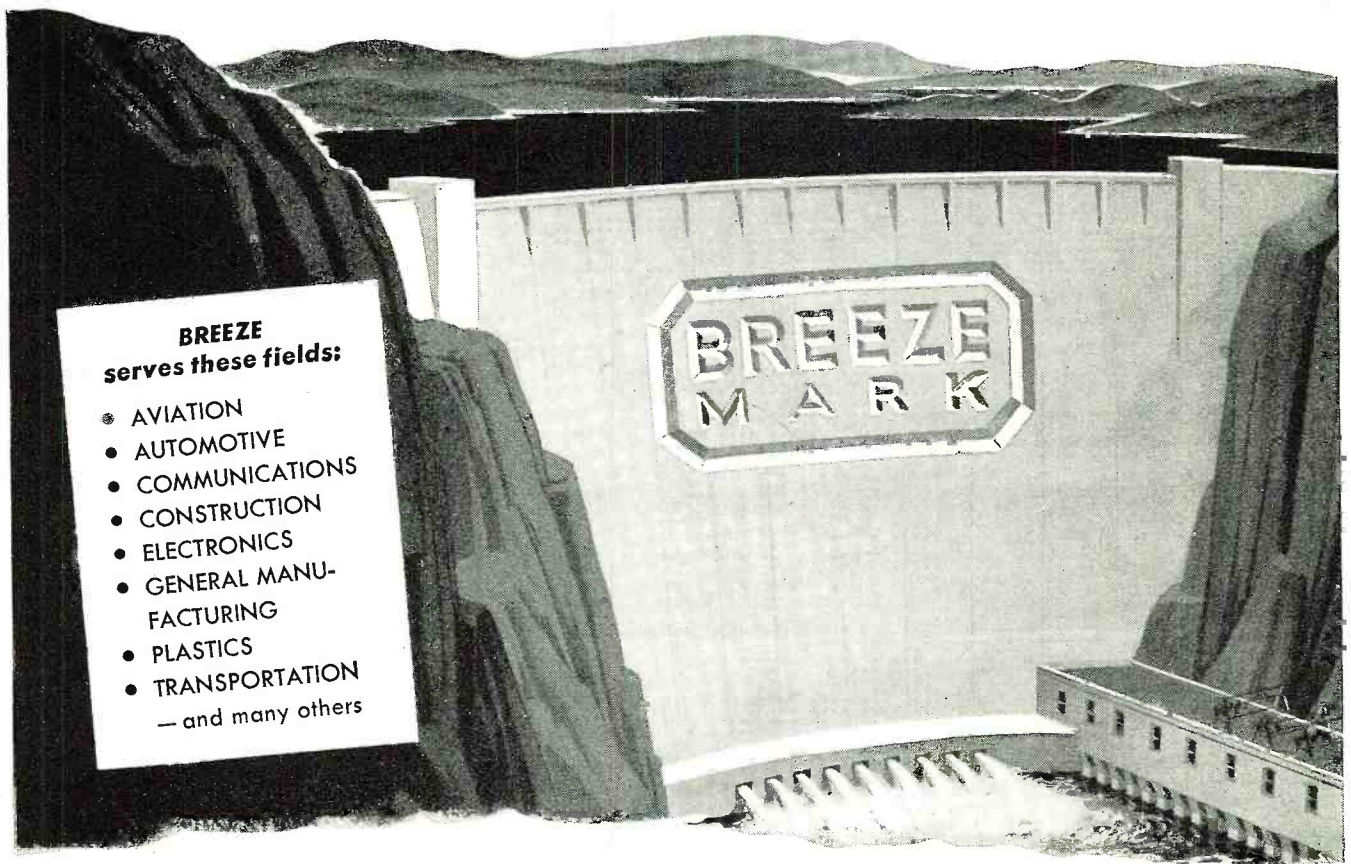

**BREEZE**  
serves these fields:

- AVIATION
- AUTOMOTIVE
- COMMUNICATIONS
- CONSTRUCTION
- ELECTRONICS
- GENERAL MANUFACTURING
- PLASTICS
- TRANSPORTATION
- and many others

THROUGH diversified manufacturing operations covering a period of nearly two decades, Breeze has built up a vast reservoir of skills and facilities which now may be tapped by manufacturers faced with reconversion problems. Already Breeze has helped two producers of consumer goods to recapture pre-war markets . . . and turn a handsome profit while their competitors were still trying to figure out what to do about re-tooling for peacetime production. And in the same manner that it has helped others, Breeze may be able to help you.

Breeze has available, on a sub-contracting basis, resources of versatile equipment and "know-how" ranging from the planning, engineering and production of intricate electronic devices . . . to the manufacture of hardened steel parts.

During the war years these resources enabled Breeze . . .

*...To solve many complex problems for the Armed Forces with the ingenuity born of 19 years of experience in the design and manufacture of products developed to meet the exacting requirements of the aviation industry.*

*... To produce in vast quantities for war such precision items as Breeze Radio Ignition Shielding, Flexible Conduit and Fittings for aircraft, automotive, tank and marine engines; Aircraft Tab Control Mechanisms, Electrical Connectors, Flexible Shafting and Casing, light-weight Armor Plate and countless other specialties.*

Today, properly applied, the Breeze processes, equipment and techniques which made so many

important contributions to Victory may enable you to get goods back on the market months ahead of your competition. The wide variety of services Breeze offers are described graphically in "Planning for Reconversion". Send for your free copy of this interesting booklet today. It may suggest a direct adaptability of Breeze skills and facilities to your commercial production needs.

**BREEZE**  
*Corporations Inc.*

NEWARK 7  NEW JERSEY



# Specialists in Special Crystals

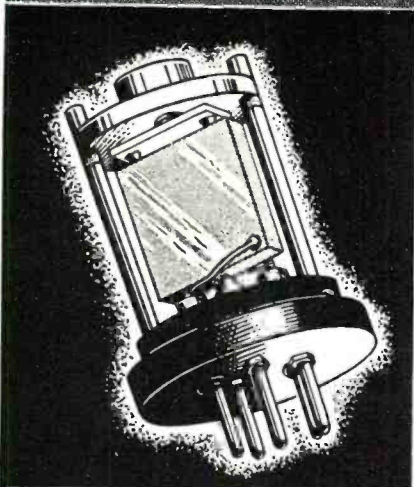

## 200-500 K. C.

### EXTREMELY STABLE CRYSTALS FOR HIGH OUTPUT AND KEYING

Clamped low frequency plated crystal units with permanent frequency precision,  $\pm 0.1\%$  from  $-30^{\circ}\text{C}$  to  $+60^{\circ}\text{C}$ ! None of the instability typical of old-style spaced units. A crystal that can take it, designed for use in such places as the 30-ton Coast Guard buoy transmitter, lighthouse transmitters, aircraft landing, etc. Each unit subjected to rigid Government specification keying tests. Mounted in aluminum hermetically-sealed holder.

- \* 3 point edge suspension. Top 2 points are spring adjusted, tamper-proof sealed for permanent frequency stability.
- \* Electrical contacts soldered to silver plate at nodal points — no mechanical strain.
- \* Hermetically sealed holder accomplished by spinning aluminum can over gasket under high pressure.
- \* Another Crystalab-engineered development.

Write RN for comprehensive catalogue "Electronic Crystals" and facilities booklet "Crystalab Solves a Problem"



Manke Ingenuity makes us

SPECIALISTS IN SPECIAL CRYSTALS

## CRYSTAL RESEARCH LABORATORIES

INCORPORATED

LABORATORIES AND MAIN OFFICE: 29 ALLYN STREET, HARTFORD 3, CONN.

New York Office: 15 E. 26th Street, New York 10, N. Y. Phone MU. 5 2552

Komsomolsk, 9.565, is reported heard on West Coast nightly at 10 p.m. with strong signals, relaying Moscow.

A letter received by an Eastern DXer from ZNR, 12.115 and 6.760, Aden, Arabia, states that the Ministry of Information broadcasts at noon were discontinued as of September 1, 1945, but does not imply that the station has dropped broadcasts altogether.

LRA1, Buenos Aires, Argentina, has shifted frequency slightly from 9.683 to 9.690 where severe QRM from Bogota, Colombia, HJCAB, is experienced; LRX1, *Radio El Mundo*, also Buenos Aires, has shifted from 6.120 to 6.115, while LRY1, formerly 6.090, has slipped two kilocycles to 6.088, which improves intelligibility through ZNS (Bahamas) and CBFW (Montreal).

PRE9, Fortaleza, Brazil, is using its 15.165 frequency for two hours on Monday nights, 6:30-8:35 p.m. The 6.105 frequency is used 3:30-6:15 p.m. on Monday and to 8:35 other days; neither frequency is heard well in the East.

In Chile, *Radio La Cooperativa Vitalicia*, Santiago, has changed bands, replacing CE615, 6.155, with CE1190, 11.900, now heard 5:30 a.m.-11:05 p.m.; interference from CXA10, Montevideo, Uruguay, is quite bad.

HJDU, 4.805, *Emissora Cultural*, at Medellin, Colombia, is reported off the air, but HJDP, 4.885, *Emissora Claridad*, at Medellin is reported back on the air again, 6-10 p.m., after more than a half year's silence. Also back on the air after an even longer absence is another Colombian, HJAB, 4.785, Barranquilla, 6-11 p.m.

*Radio Guadeloupe* has changed from 7.225 to 5.960; this station is a real wanderer.

Guatemala's TGOA, *La Voz de las Americas*, is back again on 7.305; fair strength, occasional code interference.

The frequency change announced for several months ago by CXA19, 11.705, *El Espectador*, at Montevideo, Uruguay, finally took place on October 1, resulting in great improvement in signals; new frequency is 11.835.

The *United Nations Network* station, 6.160, Munich, Germany, has not been reported recently. Only German transmitter mentioned the last few weeks is DHTB, 15.860, Berlin, Press Wireless, heard around 6:30 a.m. with a network relay.

TGX1, 6.188, Guatemala, reported returned to the air, 8 p.m.-12:30 a.m. TGNA, 7.170, also Guatemala, heard as early as 5 p.m., signing off at 8 p.m.

### BEST BETS FOR BEGINNERS

Kenneth Noyes, Los Angeles, lists these best bets: HCJB, 12.455 and 9.958, Quito, Ecuador, evenings to 11 p.m., in English and Spanish; good. FZI, 11.970 and 9.440, Brazzaville, French Equatorial Africa, evenings to 9 p.m.; strong. XGOY, 9.810, Chungking, China, mornings to 12 noon sign-off; English news at 11:10 a.m.; very good. OTC, 9.745, Leopoldville, Bel-

## Attention: RADIO SERVICEMEN

Here is the new, Jensen Phonograph Needle Saleskit designed especially for the Radio Serviceman. It's colorful, compact and convenient—just the thing for slipping into the pocket and taking on service calls...a definite aid in demonstrating fine phonograph needles...the first real saleshelp ever offered exclusively to servicemen.



Now available at your jobber. WRITE TODAY for complete details and our better than usual discount to servicemen.

Contains 3 Jensen Concert Needles retailing at \$1 each and 3 Jensen Genuine Sapphire Needles at \$2.50 each. Install the needle that augments your work, assures full clear tone of the instruments you repair.

JENSEN INDUSTRIES, INC., 737 N. MICHIGAN AVE., CHICAGO 11, ILL.



# He reads the "C-D Capacitor" and gets a chance to look around



He's not a stunt man. Just a regular radio guy like you and all the others. The reason he rides so easy is that he gets a good head start . . . keeps his nose to the ground, but has his eyes wide open. Every month he pinches a couple of minutes off his working time to read the C-D Capacitor and get the tip-off on short cuts in servicing.

Imagine! A whole month's worth of service helps that you can swallow at one sitting! Nothing for you to do . . . not a penny to send; just write us and "The Capacitor" will come to you by mail regularly. Twelve times a year we'll send you this helpful, pocket-sized magazine. Write to: "The Capacitor", Cornell-Dubilier Electric Corporation, South Plainfield, N.J.



## A TIMELY POSTER FOR YOU!



An attractive blue and yellow display card for your window or wall that reads "we use no war-weary surplus". It conveys to your customers that you use only genuine and original C-D Capacitors in all service jobs. Ask your local jobber for this poster today!

## HAVE YOU SEEN THIS CATALOG?



Quick, easy, condensed reference that gives you a comprehensive listing of the most complete line of capacitors made. Remember Cornell-Dubilier for all your servicing needs. Send for Catalog #195.



## PRACTICAL E Z's!

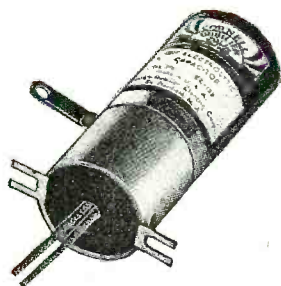

Here's one of several types of capacitors that wins the serviceman's award for "all-around replacement." Adaptable for upright or under-chassis mounting, E Z's incorporate C-D's famous etched foil features in design and construction.

**CORNELL-DUBILIER**  
the greatest name in  
**CAPACITORS**



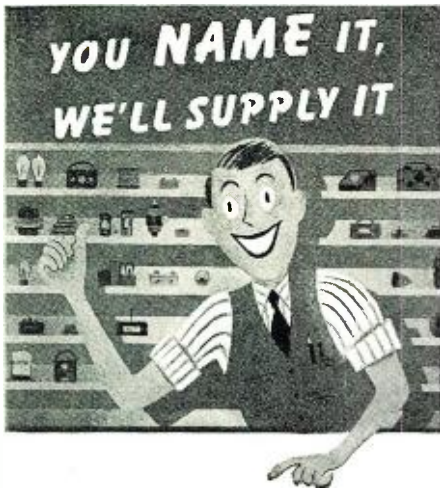

## EVERYTHING IN RADIO AND ELECTRONICS

R. W. T., world's oldest and largest Radio Supply House is ready again with tremendous stocks of sets, parts and equipment. You can depend on our quarter-century reputation for quality, sound values and super-speed service. Orders shipped out same day received. All standard lines already here or on the way, including: National, Hammarlund, R. C. A., Hallicrafters, Bud, Cardwell, Biley and all the others you know so well.

Originators and  
Marketers of  
the Famous

*Lafayette Radio*

**Radio Wire  
Television Inc.**



100 Avenue of the Americas  
(Formerly 6th Ave) New York 13  
Boston, Mass. • Newark, N. J.

**R. W. T.** DEPT. RA-6, 100 AVENUE OF THE  
AMERICAS, NEW YORK 13, N. Y.

I want your big new post-war Catalogue.

NAME \_\_\_\_\_

ADDRESS \_\_\_\_\_

HAM?  (CALL LETTERS) \_\_\_\_\_

ENGINEER?  SERVICE MAN?  STUDENT?

gian Congo, heard to 11:45 p.m., relaying London's North American Service; strong. Radio Australia, 9.615, 9-10 a.m., and on 11.840, 11-11:45 a.m.; English news at 11 a.m.; very strong; also on 11.840, 12:10-12:45 a.m., in parallel-with 11.71, news at 12:15 a.m.; good to very good. Bern, Switzerland, on 9.185, 8:30-10 p.m., news at 8:45 p.m.; very good.

From Sand Lake, New York, Harry E. Kentzel sends along these best bets: Bern, Switzerland, 7.38 and 9.185, every evening except Saturday, 8:30-10 p.m. Armed Forces Network Station in London (or Paris), approximately 6.080, has excellent signal around 1 a.m. and later. HCJB, 12.455, Quito, Ecuador, an old standby, has fine signals every evening. XEWW, 9.500, Mexico City, has fine signals late evenings.

Jim Johnson, Chicago, offers these best bets: HCJB, 9.958, Quito, Ecuador, 9-11 p.m. Paris, 9.520, 9-9:30 p.m. VLC2, 9.68, Radio Australia, 8-8:45 a.m., with carrier wave on 10 minutes before transmission begins. HEF4, 9.185, Bern, Switzerland, news at 8:45 p.m., messages for U.S. servicemen, 9:50 p.m. Madrid, Spain, 9.370, 3-3:30 p.m., news and commentaries in English. BBC stations, GRJ, 7.32, European Service, 4 p.m.; GSW, 7.230, in parallel; GRS, 7.075, General Overseas Program, 4 p.m.

### LAST MINUTE TIPS

Paul Dilg (California) flashes:

AUSTRALIA—Perth's VLW7, 9.52, opened at 5:30 a.m. on a recent Saturday, ran to 11 a.m.; signed on Sunday at 10:30 a.m.; may have a longer schedule on Saturday only, when woman signed medium wave stations at 10:45, but VLW7 continued with music and signed at 11 a.m. by playing *God Save the King*.

NEW CALEDONIA—Noumea on 6.205, fairly good signal, leaves the air at 5 a.m.

HONGKONG—ZBW, approximately 9.465, opening unknown but heard weakly at 4:50 a.m., sign-off is at 8:30 a.m.; news at 7, 8 a.m.; at present one of poorest Asiatics.

CHINA—A station heard on 7.50, call seemed to end in R, picked up at 5 a.m., woman talked Chinese to 6 a.m. when they left the air; a very early sign-off for China, possibly moved to another frequency. A Chinese on 9.69 good (Sunday), sign-off was at 9:20 a.m., sensed they said "Taiwan" and call as XGUA or XGUE; relayed Chungking news at 9 a.m.

INDIA—VUC2, Calcutta, 3.305, heard at 8:45 a.m. and later. VUD, 9.67, is one of the best now that KU5Q, Guam, is not on the air so much, leaves the air at 10:30 a.m., may be just a break.

INDONESIA (JAVA)—*Indonesian Republic* station on 6.72, signed at 9:30 a.m.; believe they open about 5:30 a.m.; news in English given at 7:30 a.m.; announced in English at 8:30 a.m.; played American music to 9 a.m. after which, until sign-off, had foreign talk and foreign vocal music.

JAPAN—Tokyo's JLR, 6.015, Home Service in dual with JLG, 7.285, heard around 5 a.m. but not after 7:30 a.m.; JLT, 6.19, Home Service in dual with JVV, 7.26, heard around 5 a.m. but not after 8:30 a.m.; JVV, 7.26, Home Service, schedule unknown but heard between 5 a.m. and 8:30 a.m.; good signal; in dual with JLT, 6.19; JLG, 7.285, Home Service in dual with JLR, 6.015, schedule unknown but heard from 5 a.m. to 7:30 a.m., very strong signal.

KOREA—On 2.510 heard at 6:30 a.m. with native talk, signal weak.

PORTUGUESE CHINA—Macau, 7.530, believed now to be on 7.525 instead of 7.53; native heard before 6 a.m.; schedule unknown but heard around 5:15 a.m. badly QRM'd by telephonic station, possibly KKH on 7.52; at 6:07 a.m. announced in English after Chinese, followed by American recordings without reading titles; at 7 a.m. had music and vocal, seemed to be in Portuguese; news read in English at 7:40 a.m., lasting 10 minutes; sign-off was at 9 a.m. (The following day Dilg reported definitely that Macau signs off at 9 a.m. and that the news heard at 7:40 a.m. is *not* relayed from Shanghai; woman said "Macau" and gave only one short-wave frequency, the other one given was medium-wave on 245 meters.) Dilg says Macau's signal is good, but the voice mike is weak. The 25-meter band is very poor, with the 49- and 41-meter bands improving daily, Dilg concludes.

From New Zealand it is reported that *Radio Andorra* verifies reception with a card showing antenna masts in the Pyrenees, printed in Spanish, giving address as Radio Andorra, Andorra la Vieja, Principality of Andorra.

Also from New Zealand comes a report that a letter verification was recently received from *La Voce dell'Italia*, Rome, on 6.025, giving schedule as 1-1:45 a.m., 7-8:15 a.m., 12:30-5:40 p.m.; power is 20 kw. and address is Via delle Botteghe Oscure 54, Rome, Italy. This station is reported from another source to be back on the air, heard to 6 p.m.

Brazzaville's 17.530 radiation is reported as well heard, 12-1:25 a.m., in the East, with the 11.970 frequency heard regularly on the West Coast during this transmission.

India reverted to Standard Time on October 15, 1945. Programs for abroad were mainly unaffected, but radiations for India and Ceylon are being heard one hour later. A number of seasonal and postwar changes, plus the time change complication, are causing radical alterations in Delhi schedules.

From New Zealand, *Art Cushen* reports that John Moody, news announcer at *Singapore Radio* in prewar days, escaped from internment and was waiting at the studio to resume his old job when British occupation forces arrived in Malaya. John de Merrick, announcer, also held this position before the war. Cushen reports that Singapore Radio on 15.450 was heard irregularly at 3:45 a.m. calling

**RADIO NEWS**



Two big NEWARK stores well stocked to serve your needs and staffed by people who know and can help solve your problems.

# THIS MONTH'S FEATURES

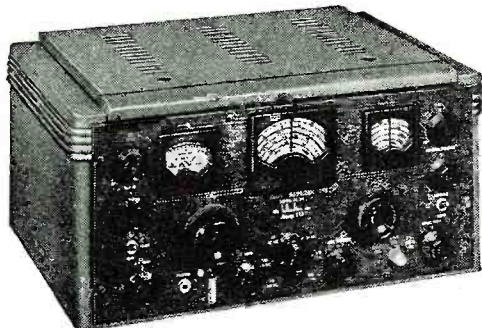

### HALLICRAFTERS

- SX-28A Super Skyriider with crystal, less speaker.. \$223.00
- S-20R Sky Champion with built-in speaker..... 60.00
- S-22R Skyriider Marine with built-in speaker..... 74.50
- SX-25 Super Defiant with crystal, less speaker... 94.50
- S-39 Sky Ranger portable, AC/DC and battery. 110.00
- SX-36 FM/AM receiver..... 415.00
- S-37 V.H.F. FM/AM receiver..... 591.75
- PM-23 10" PM speaker in cabinet for use with SX-25, SX-28A..... 15.00

### THORDARSON TRANSFORMER (POWER TRANSFORMERS AND CHOKES)

- T-45556 or T-92R21 leads out of side, 778 V. C.T. at 200 MA. 115 V. 60 Cycles 6.3 V. C.T. at 5A. 5 V. at 30 amp. 91 lbs..... \$3.29
- T-13C30 8H. 150 MA. 200 ohm 1600 V. Insulation 2 1/4 lbs..... 1.41
- T-4557 or T-74C29 leads out of side. 15H. 150 MA. 200 ohm 2000 V. Insulation 5 1/4 lbs.... 2.82

### HAMMARLUND

- HQ-129X (with tubes)..... \$129.00
  - ASPC-210X..... 318.00
  - ASP-210SX..... 318.00
- Available for rack mounting at same prices

### NATIONAL

- NC-2-40C and speaker..... \$240.00

### RME

- RME-45 and speaker..... \$166.00



### WESTERN ELECTRIC MICRO AMMETERS



Bakelite case fits 3 3/4" hole. Radium dial 150-0-150. Can be used with 0-200 micro and amp scale listed below. Excellent as a 5,000 ohm-per-volt meter or null, sound level and galvanometer indicator. Instructions included. No priority required..... \$7.50  
0-200 paper scale for above..... .15

## THE FAMOUS NEWARK BARGAIN OIL-FILLED, OIL-IMPREGNATED FILTER CONDENSERS

FULLY GUARANTEED AT RATED VOLTAGES



Capacity	Working Voltage	Height	Width	Depth	Wt.	Price
1 mfd.	1500 V. D.C.	2 3/16	1 3/4	1	4 oz.	\$ .79
17 1/2 mfd.	1500 V. D.C.	3 3/8	4 3/8	3 3/4	3 lbs.	2.75
11 1/2 mfd.	1500 V. D.C.	5	3 3/4	1 1/2	1 lb. 10 oz.	2.00
5 mfd.	1500 V. D.C.	4	2 3/8	1 1/4	14 oz.	1.65
5 mfd.	2000 V. D.C.	4	3 3/4	1 1/4	1 lb. 4 oz.	2.15
8 mfd.	2000 V. D.C.	4 1/2	3 3/4	2 1/2	2 1/2 lbs.	2.75
25 mfd.	2000 V. D.C.	3 3/4	1 3/4	1	6 oz.	.69
Special Porcelain Insulators						
10 mfd.	3000 V. D.C.	4 7/8	3 3/4	3 1/4	3 lbs. 8 oz.	4.75
15 mfd.	3000 V. D.C.	4 3/4	4 3/8	3 3/8	5 lbs.	5.25
6 mfd.	3000 V. D.C.	6 3/8	6 1/2	3	5 lbs. 6 oz.	3.25
with mounting feet, width includes mounting feet						
8 mfd.	3000 V. D.C.	7 3/8	6 1/2	3 3/8	7 lbs. 4 oz.	3.95
2 mfd. & 4 mfd.	600 V. metal can	4 7/8	2 1/2	1 1/4	14 oz.	.80

### McELROY KEY

The Deluxe — Model CP 810.....\$9.75

### GENERAL ELECTRIC METERS

0-500 D.C. MA. 2" round Bakelite case.....\$3.50

0-8 RF ammeter, 2" round Bakelite case.....\$4.00

### ABBOTT TR-4

Compact, efficient 2 1/2 meter transmitter-receiver \$39.00

### Get Your Name on Our Mailing List

Be first to get announcements of merchandise available, special bargains, etc., etc. Send name and address on post card. State whether amateur, engineer school, industrial or service man. Address orders and inquiries to Dept. Q, at NEWARK store nearest you.



ALL PRICES SUBJECT TO CHANGE WITHOUT NOTICE

CHICAGO  
NEWARK  
NEW YORK  
**NEWARK ELECTRIC Company**

115-117 W. 45th St.  
NEW YORK 19  
BRyant 9-4735  
(Adolph Gross)

"Dependable Service is the Foundation of our Business"

323 W. Madison St.  
CHICAGO 6  
DEArborn 0083  
(Sam Poncher)



# POSTWAR RADIO TRANSFORMERS

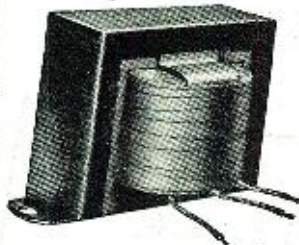
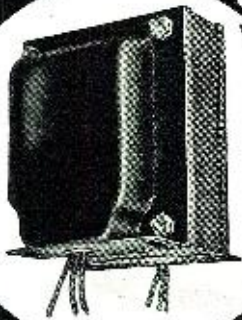

THE ACME ELECTRIC & MFG. CO.  
CUBA, N. Y.

Acme Electric

Wellington, New Zealand, with POW messages for New Zealand.

Doula, Cameroons, is reported on both 6.890 and 11.530.

In the fall, KK2T, aboard the *USS South Dakota*, was picked up on 15.505 and 15.575. A letter received from Guam states that KUIM, aboard *USS Iowa*, transmitted on 10.640, 13.775, and 17.680; they also stated that ZIJ, Okinawa, used the very same frequencies, but, of course, not simultaneously. The *USS Missouri*, MCBL or NCBL, 19-meter band (15.593), was picked up 4-5 p.m., October 19, contacting WQV and WQD, New York; announced another frequency they were using in the 7-megacycle band. (While making arrangements for Navy Day broadcasts in October, NCBL was heard on 15.593, 14.770, and 9.970; excellent signal in West Virginia on 15.593; uses 3 kw. power.) JBC, 15.135, Batavia, Java, was heard 6-7 p.m., mostly native music; announcer stated that they would soon have a regular program consisting of talks on their native land, etc. (Hanson)

*Radio Congo Belge*, 9.385, heard at 2:30 p.m. (Harris)

Chungking is back on winter time. Chungking's XGOY, 9.810, was heard recently to leave the air at 1 p.m.; generally signs at 12:35 p.m. Canton, 11.65, has English news at 9 a.m. as does XPSA, 7.01, Kweichow Broadcasting Station at Kweiyang City, capital of Kweichow Province, and XGAP, 6.095, Peiping; relay news from Chungking's XGOY.

From *John J. Kernan*, Roxbury, Boston, come these details of his pick-up of FXE, 8.020, *Radio Bierut*, Lebanon: Carrier comes on at about 10:55 p.m.; uses 4-bell tone signal to 11 p.m., when they play the French national anthem, 1 verse; then they call out the station in French, "and you can really hear him say *Radio Lebanon*." Play a short French march; news in French is heard then, followed by news in Arabic at 11:15 p.m. At 11:30 p.m. usually has Arabian music, chanting, strings, quite like that heard from Indian stations. Mr. Kernan reports he has not heard *Radio Damascus*, 8.000, since late summer, and that FXE comes through irregularly, with much CW QRM.

*Buddy Giles*, Wichita Falls, Texas, recently discharged from the Coast Guard, writes that he has received a letter verie from ZOJ, 11.810, Colombo, Ceylon, which states use of a 7½-kw. transmitter; they answer via airmail.

*Rex Gillett*, DX Editor, *Radio Call*, South Australia, writes me that a verie has been received by Ern Suffolk, of Lobethal, Australia, from *Radio Somali*, address being Department of Information and Broadcasting, Government Headquarters, Hargeisa, British Somaliland. Gillett says to listen for *Radio Somali* at 9 a.m. on 7.126 when the BBC news is relayed from London; sign-off is at 9:30 a.m. He reports a good signal from *Ici Radio Francais*, Algeria, 12.115, around 12 midnight. During the summer, Prague

on 9.550 was heard afternoons, closing down at 5 p.m.; an English announcement, "This is the voice of Czechoslovakia calling from Prague," was heard in the English session from 3:30 to 4 p.m. JCKW, 7.220, Jerusalem, Palestine, is heard well in Australia, afternoons. The Madrid, Spain, station on 9.370 is heard in English, 3-3:30 p.m., male and female announcers. Stockholm, Sweden, SDB-2, 10.78, and SBU, 9.53, have been heard in Australia, in English, around 12:30 p.m. Bern, Switzerland, on 6.345 and 9.185, are heard in French daily, closing at 5:20 a.m. TAQ, 15.200, Ankara, Turkey, heard with native program at 4:30 a.m. *Radio Dakar*, 11.715, Senegal, is heard in French, 2:10-2:30 a.m. HVJ, 9.660, Vatican City, concludes an English transmission at 1:30 p.m. PY11, 11.64, Manila, Philippines, heard contacting KJE8, Los Angeles, strong at 7 a.m. Widely heard is *Radio Luxemburg 2*, 6.02, 11 p.m.-2 a.m., 5-7 a.m., and noon-4 p.m.; at close has been announcing, "This is Radio Luxem-

(Continued on page 146)

## U.H.F. Measurements

(Continued from page 34)

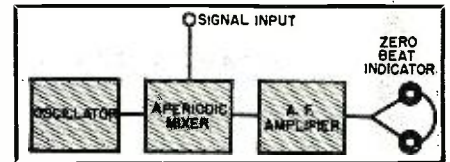

Fig. 8. Heterodyne frequency meter.

strument and laid beside an inch scale for size comparison.

In addition to its prime function as a frequency meter, this instrument may be employed as a 200-700-mc. receiver having a sensitivity (when used with the tuning units) of 100 microvolts (for a 30-microampere deflection of the d.c. output meter) at 200 mc. and 20 microvolts at 700 mc. The sensitivity rises somewhat in the vicinity of 400 mc.

*General Radio Type 720-A.* The

Fig. 9. Butterfly condenser.

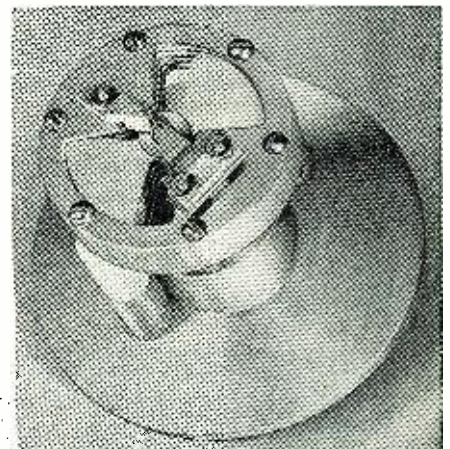

RADIO NEWS



# CRONAME *Facilities*

FOR ELECTRONIC COMPONENTS  
AND FINE METALCRAFT

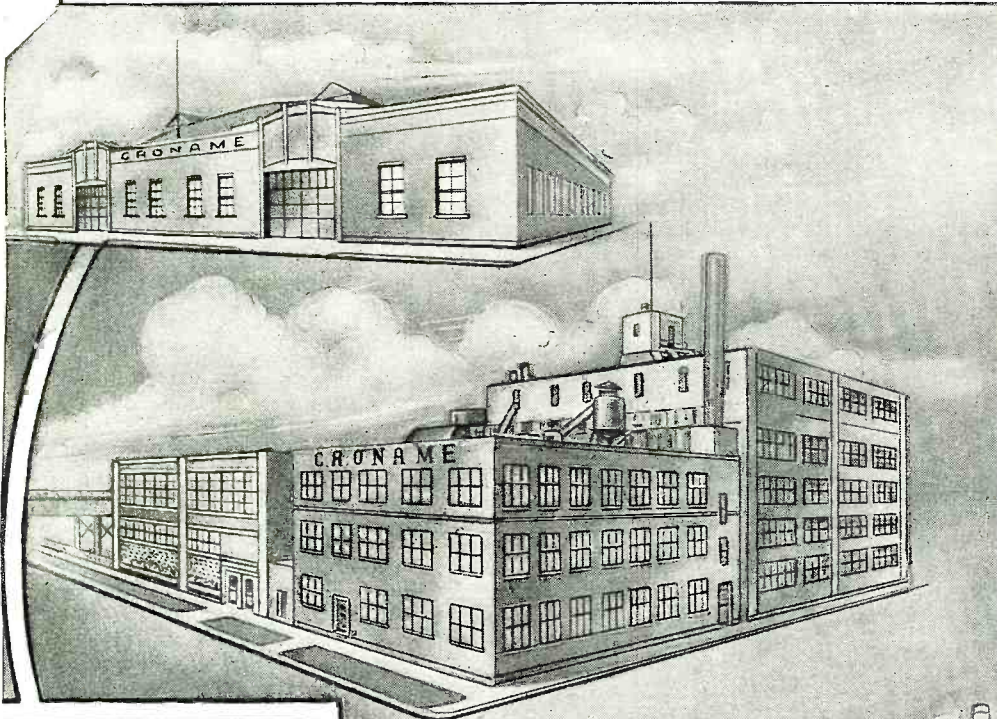

ENGINEERING  
ETCHING  
LITHOGRAPHING  
EMBOSSING  
ENGRAVING  
STAMPING  
ALUMINUM WELDING  
& HEAT TREATING  
ASSEMBLIES  
SOLDERING  
METAL FINISHING  
PLATING

ANODIZING  
PARKERIZING  
OXIDIZING  
FLUORESCENT  
PHOSPHORESCENT  
DECORATED GLASS  
GLASS DIALS  
DECORATED PLASTICS  
FORMED PLASTICS  
RADIO TUNING UNITS  
REMOTE CONTROLS

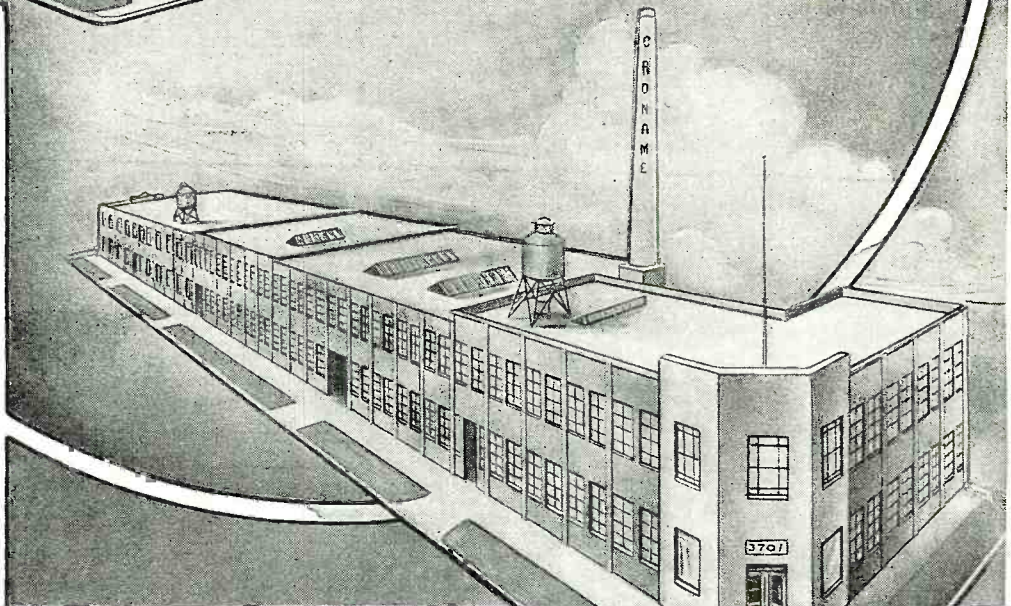

OVER 40 YEARS EXPERIENCE IN FINE METALCRAFT



**CRONAME**  
INCORPORATED

3701 RAVENSWOOD AVENUE  
CHICAGO 13, ILLINOIS



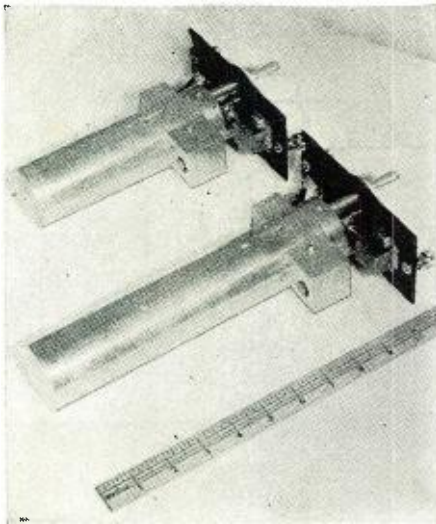

Fig. 10. Photograph of the two tuned, plug-in cavities used to cover the 200-700 megacycle range in the v.h.f. calibrator illustrated in Fig. 6.

block diagram of Fig. 11 shows the arrangement of stages in the *General Radio* Type 720-A heterodyne frequency meter. The basic operating principle of this instrument is the same as that of heterodyne frequency meters employed at lower frequencies (see description of the heterodyne frequency meter in an earlier section of this article). Important differences in this instrument, however, are: (1) the dial-calibrated oscillator (tunable from 100

to 200 mc.) has a butterfly tuning unit with logarithmic characteristic; (2) the detector (mixer) is a *fixed crystal* of the type illustrated in Fig. 2; and (3) the beat note (audio) amplifier has a band width of 50 kc. This latter feature makes it possible to check a signal which is not stable enough ordinarily to produce a steady beat note. The 720-A meter checks frequencies between 10 and 3000 megacycles.

When checking a frequency below 100 mc. the signal is tuned in at several points, starting at the lower end of the megacycle-calibrated dial. The distance (in megacycles) between any two successive beats on the dial will then equal the unknown signal frequency. When checking a frequency between 100 and 200 mc. the unknown frequency may be read directly from the oscillator dial, since it is a fundamental of some oscillator frequency. When checking frequencies over 200 mc., strong beat notes are noted, starting tuning from the higher end of the calibrated oscillator dial. The frequency of one of these beats (as read from the dial) may be divided by the difference between this frequency and that of a successive beat to obtain the *harmonic number*. The lower successive beat frequency (just observed on the dial) multiplied by this harmonic number equals the unknown frequency. Example: Beats are noted at 180 mc. and 150 mc. The harmonic number then is equal to 180 divided by 180-150. This is 180/30, or the har-

Band	MC.	Node Separation (Inches)	Bandwidth (Movement of Bar—Inches)
A	220	26.85	0.60
	221	26.75	
	222	26.82	
	223	26.50	
	224	26.40	
B	225	26.25	0.92
	420	14.05	
	430	13.72	
	440	13.43	
C	450	13.13	0.42
	1145	5.16	
	1200	4.92	
D	1245	4.74	0.16
	2300	2.57	
	2350	2.51	
	2400	2.46	
	2450	2.41	
	5250	1.12	
E	5300	1.11	0.08
	5400	1.09	
	5500	1.07	
	5600	1.05	
	5650	1.04	
F	10,000	0.590	0.03
	10,100	0.585	
	10,200	0.580	
	10,300	0.573	
	10,400	0.568	
	10,500	0.563	
G	21,000	0.281	0.01
	21,250	0.278	
	21,500	0.274	
	21,750	0.272	
	22,000	0.269	

Table 1. Lecher wire data.

monic number is 6. The unknown frequency is 150 (6) = 900 mc.

#### REFERENCES

The amateur who desires to make a complete study of higher-frequency measuring equipment is referred to the following works, in which he will find readily understandable material:

- CAVITIES**  
*Basic Radio* (6th Printing). Hoag. PP. 328-332. (Van Nostrand)  
*Klystron Technical Manual*. PP. 7, 12, 19, 70. (Sperry Gyroscope Co.)  
*Radio Amateur's Handbook* (22nd Ed.). P. 56. (American Radio Relay League)  
*Radio Engineer's Handbook* (1st Ed.). Terman. PP. 264-273. (McGraw-Hill)

**V.H.F. CRYSTAL DETECTORS**  
 Vacuum-Tube and Crystal Rectifiers as Galvanometers and Voltmeters at Ultra-High Frequencies. *General Ra-*

# ELECTRICITY

## FOR RADIO AND ELECTRONIC APPLICATIONS

• ONAN ELECTRIC GENERATING PLANTS supply reliable, economical electric service for electronics applications as well as for scores of general uses.

Driven by Onam-built, 4-cycle gasoline engines, these power units are of single-unit, compact design and sturdy construction. Suitable for mobile, stationary or emergency service.

Model shown is from W2C series. 2 and 3-KW, 60-cycle, 115 volt; powered by water-cooled 2-cylinder engine.

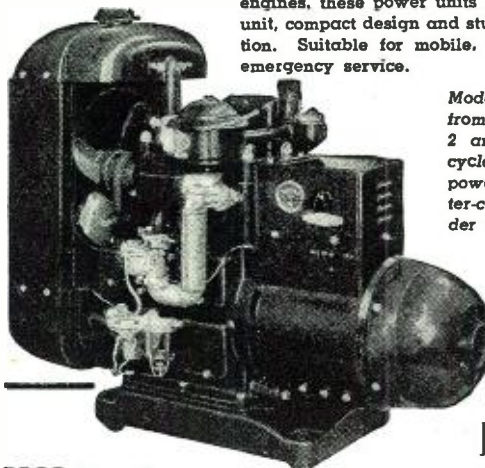

Models range from 350 to 35,000 watts. A.C. types from 115 to 660 volts; 50, 60, 180 cycles, single or three-phase; 400, 500 and 800 cycles, single phase; also special frequencies. D.C. types range from 6 to 4000 volts. Dual voltage types available. Write for engineering assistance or detailed literature.

**D.W. ONAN & SONS**  
 MINNEAPOLIS 5, MINN.

2168 Royalston

Avenue.

### Radio Servicemen: RADIO PARTS—TUBES

BARGAIN PRICES—NO PRIORITIES  
 TUBES—12SK7, 12SQ7, 25L6, 50L6, 6Y6GT... \$0.85  
 TREQOR 450 OHM SPEAKERS, 4 or 5 inch... .39  
 FILTER COND., 20-20 MFD, 150 V... .39  
 5V PASS COND., .01, .02, .05, 1-400 V... .57  
 VOL. CONT., 5 Meg., W. SW, Tap, 3" Shaft... .59  
 ANT. & OSCIL. or ANT. and RF COIL SETS... .59  
 RESISTOR KIT—50 Ass'd, 1/4 to 1 Watt... .99  
 Write Today for Bargain Bulletin  
 RADIO DISTRIBUTING CO., Pasadena 18, Calif.

**RCA Institutes, Inc.**  
 Offer thorough training courses in all technical phases of Radio and Television  
**WEEKLY RATES: VETERANS: DAYS—EVENINGS**  
 For Free Catalog write Dept. RN-46  
 RCA INSTITUTES, Inc.  
 A Service of Radio Corporation of America  
 75 Varick St., New York 13, N. Y.

Fig. 11. Line-up of the General Radio heterodyne frequency meter.

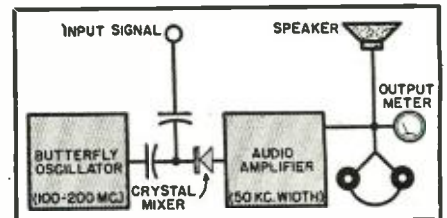



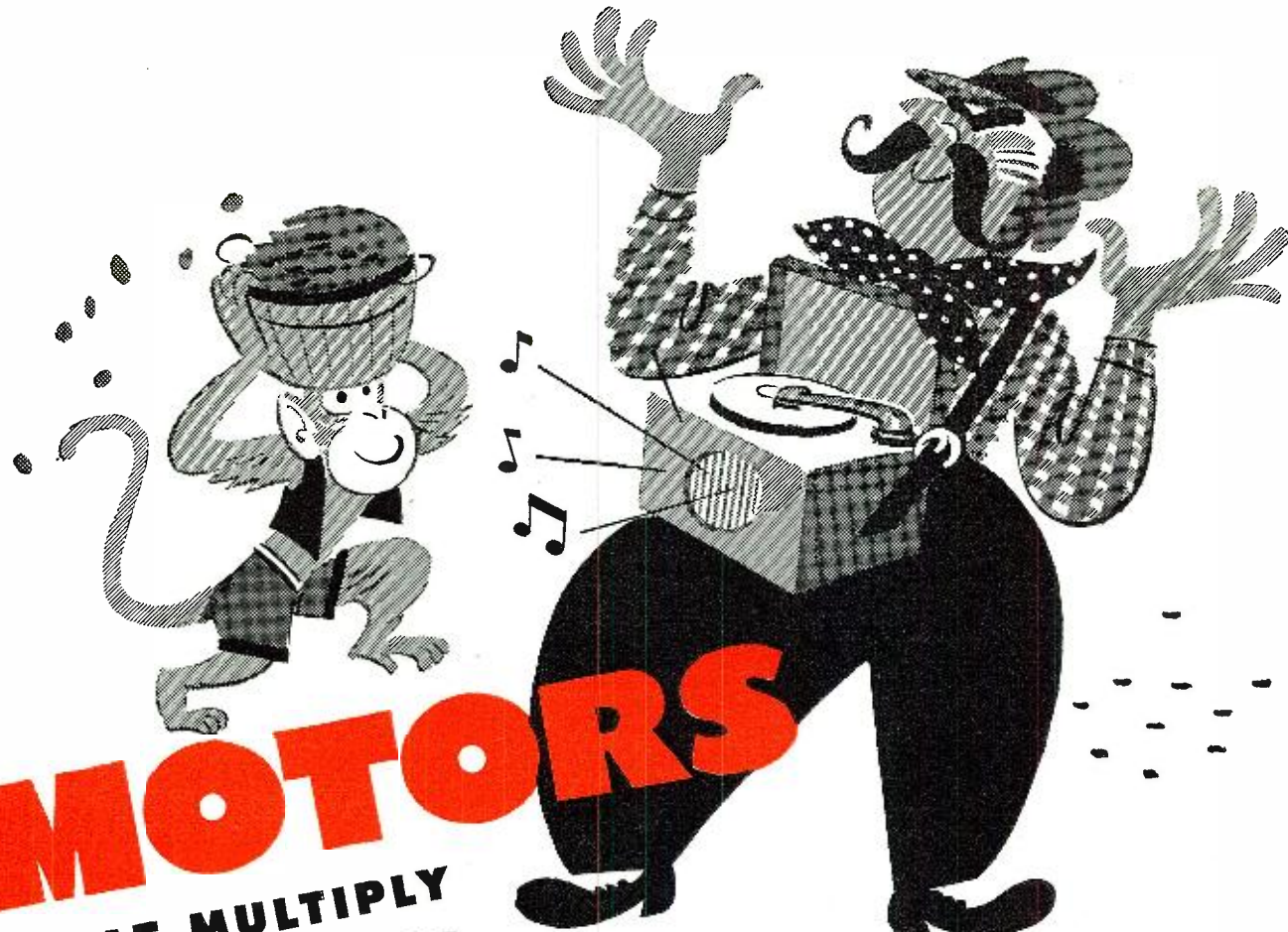

The illustration shows a monkey on the left, wearing a hat and a vest, holding a large record. On the right, a man with a mustache, wearing a polka-dot shirt and a checkered jacket, is playing a record on a turntable. Musical notes are shown around the man's turntable. The word "MOTORS" is written in large, bold, red letters across the middle of the illustration. Below it, the text "THAT MULTIPLY YOUR TURNOVER" is written in black, slanted letters.

# MOTORS

THAT MULTIPLY  
YOUR TURNOVER

Sweet music—the kind that makes satisfied customers—is yours when Alliance phonomotors drive your turntables, record changers and recorders.

Manufacturers, retailers and service shops everywhere like to “make ’em move” with Alliance. That’s because Alliance is the recognized leader when it comes to turning out little motors in large quantities at low cost.

For original equipment or replacement the years have proved that Alliance assures trouble-free performance and long life!

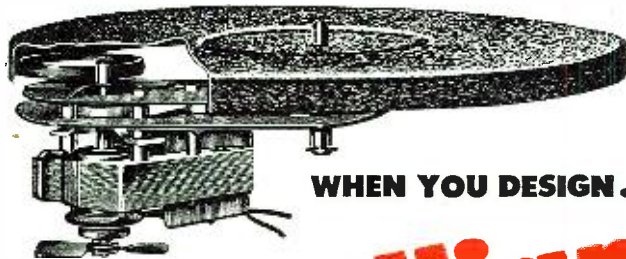

WHEN YOU DESIGN...KEEP

**alliance**  
IN MIND

**THE NEW MODEL 80** “Even-speed” phonomotor is smooth, cool running and quiet. Larger bearings with ample oil reservoirs prolong life. New shock mountings almost eliminate vibration of motor and idler plate. Equipped with 60 cycle friction rim-type drive.

**NEW USES**—For automatic and non-automatic electronic control devices and the power sources to actuate mechanical or push-button controls, Alliance motors offer the most practical engineering economy in advanced designs.

ALLIANCE MANUFACTURING COMPANY • ALLIANCE, OHIO

January, 1946

113



dio Experimenter, Vol. 19, No. 12  
WAVEMETERS

A General Purpose Wavemeter. *General Radio Experimenter*. Vol. 17, No. 4

Direct-Reading Wavemeter for Ultra-High Frequencies. *General Radio Experimenter*. Vol. 15, No. 3

Klystron Technical Manual. PP. 70-72. (Sperry Gyroscope Co.)

Specialized high-frequency wavemeter material may be found in the various editions of the *Radio Amateur's Handbook*. (American Radio Relay League)

V.H.F. Frequency Meters

A Heterodyne Frequency Meter for 10 to 3000 Megacycles. *General Radio Experimenter*. Vol. 20, Nos. 2 and 3.

-30-

### R.f. Chokes at U.h.f.

(Continued from page 55)

lowing analogy: A lead 1" long at 100 megacycles has the same inductive reactance that a lead 84" long has at standard broadcast frequencies. How absurd it is to think of hanging an 8-foot connection lead in an AM receiver.

Remembering this construction hint will save many hours of time searching for the cause of trouble in new FM sets.

Now for a sample design of a choke. Let's say a choke is desired for the

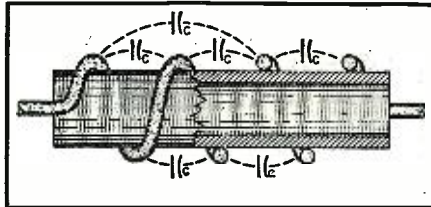

Fig. 5. Distributed capacities that will have effect on the operation of choke.

plate circuit of a local oscillator of an FM set (Fig. 3A). An excellent high-frequency oscillator tube is the Radiotron 6C4 miniature triode. The first factor that comes into consideration is the current that the plate will draw at maximum output. In the design chart shown in Fig. 4, values are given for chokes wound on two different sized cores, using No. 36 single silk enamel wire. The No. 36 wire can carry 25 milliamperes. One watt, 13/32"-diameter, and one-quarter watt, 7/32"-diameter, ceramic insulated resistors are the two sizes of forms covered by the chart. Plate current in a small receiving tube is generally not over 25 milliamperes, so the No. 36 wire will suffice for this circuit.

A point in the middle of the band is the optimum frequency to choose for the design. The present band is 88 to 108 megacycles; therefore, 98 megacycles will be the design frequency for our choke. On the chart, using

a 7/32" form, it can be seen that 51 turns will fulfill the specifications.

To begin construction, sandpaper the marking paint off the body of the resistor and solder one end of the wire to a terminal lead. After winding the required number of turns, cut the wire to size and fasten it to the other lead with solder, being careful to keep the coil tight, neatly wound, and closely spaced. If the design chart has been followed with any degree of accuracy, a choke has been made that is applicable in either the plate or the grid leak circuit of the oscillator,  $RFC_1$ , and  $RFC_2$  of Fig. 3. Two identical coils should be wound.

All the design and construction details presented in this article are important. Following them will not insure success, of course, but it will certainly be a tremendous aid. The following are a number of general construction rules for u.h.f. work:

1. Keep all leads as short as possible;
2. Construct the chassis, circuit, and other parts sturdily;
3. Do not use inferior components.

Even though u.h.f. is a new field, the amateur or radio serviceman should not hesitate for a moment to enter it, for it is an unexplored wilderness with great opportunities for fascinating home research.

-30-

### Signal Generator

(Continued from page 37)

highest range, it can be used to calibrate the u.h.f. signal generator.

A receiver capable of tuning the entire range of the u.h.f. generator is also required. A superregenerative receiver using a 955 with very short leads and plug-in coils is satisfactory. Such a detector is diagrammed and sketched in Fig. 8.

Allow all equipment to warm up thoroughly. Couple the output of both generators to the receiver. Tune the

Fig. 7. Bottom view of chassis. Attenuator switch can be seen near left side.

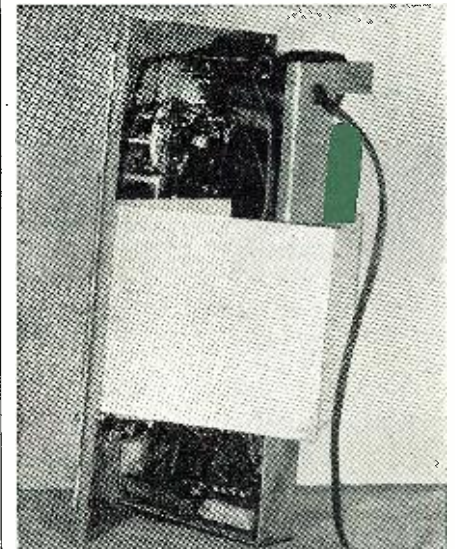

Watch

MILO

Headquarters for Radio  
and Electronic Equipment

of NATIONALLY KNOWN PRODUCTS

Component Parts  
Recorders  
Testing Equipment  
Sound Equipment  
FM and Television Radios

Selling to Industrial Firms,  
Schools, Amateurs, Service-  
men, etc.

Milo Features Trained Sales Technicians to Expedite and Handle Your Orders with Utmost Efficiency!

MILO

Radio and Electronics Corp.

200 GREENWICH STREET, NEW YORK 7, N. Y., BEekman 3-2980



# The Mark of Quality



The initials "CRL" in the Diamond stand for Centralab

They are an integral part of the Centralab name, and for more than a quarter of a century have represented the utmost in engineering skill and precision . . . the height of manufacturing perfection.

Both in original equipment and in replacements, the symbol "CRL" is the Mark of Quality.

. . . Always specify Centralab.

Ceramic High Voltage Capacitors  
Bulletin 814

## Centralab

Division of GLOBE-UNION INC., Milwaukee

PRODUCERS OF

Ceramic High Voltage Capacitors  
Bulletin 814

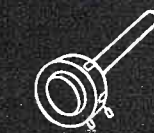

Variable Resistors  
Bulletin 697

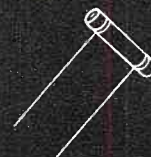

Tubular Ceramic  
Capacitors  
Bulletins 630  
and 586



Selector Switches  
Bulletin 722



Ceramic Trimmers  
Bulletin 695



# Attention GI JOE!

Here's Your Opportunity to be First to  
**Start Your Own  
 RADIO SERVICE  
 SHOP**

Complete Starting-in-Business  
 Package Stocks of

**TEST EQUIPMENT  
 TUBES, PARTS, TOOLS**

**\$350 up**

Act quickly! Meet the pent up demand for radio service. Turn your special service training into a profitable business of your own. No fuss. No worry. Here's everything you need—\$350 up. Details upon request! Write, wire or phone



### TRIPLETT Volt-Ohm-Milliammeter

**A. C. D. C. Volts**  
 0-10-50-250-1000-5000  
 at 1000 ohms per volt.

**D. C. Milliamperes**  
 0-10-100-500

**Ohms** 0-300-250,000

**Case Black molded**  
 3 1/8" x 5 1/8" x 2 1/8"

**\$16.00 net**

## Good News!

ALL  
 PRIORITIES LISTED

### HALLICRAFTERS SX-28A

**\$223**



SUPER DEFIANT	SX25	\$94.50
SKY CHAMPION	S20R	60.00
SKYRIDER MARINE	S22R	74.50
SKY RANGER	S39	110.00
ECHOPHONE	ECIA	29.50

ORDERS FILLED AS RECEIVED!!!

### MASCO AMPLIFIERS



Complete with tubes.

17 Watt **30.30**

25 Watt **42.60**

35 Watt **54.60**

50 Watt **70.50**

17 Watt with Phono-top **42.30**

25 Watt with Phono-top **52.20**

35 Watt with Record-changer **69.10**

### PHILCO BEAM OF LIGHT

Selenium Cell only, no holder **1.80**

20% deposit required on all C.O.D. orders. 2% transportation allowance on orders of \$25.00 or more accompanied by payment in full.

Write for  
**FREE CATALOG**

**RADIO SUPPLY &  
 ENGINEERING CO., Inc.**  
 129 SELDEN AVE. DETROIT 1, MICH.

u.h.f. generator to its lowest frequency, which will be around 135 megacycles. Have the attenuator in the high output position. Tune the signal in on the receiver. Reduce generator output until signal is quite weak.

Next, tune the all-wave generator until its harmonic is also heard in the receiver. Tune it until it is "zero-beat" with the other oscillator signal. Assuming this occurs at 45 megacycles, the receiver and u.h.f. generator are tuned to its third harmonic on 135 megacycles. To eliminate the extremely remote possibility that either the second harmonic on 84 megacycles or the fourth harmonic on 168 megacycles is being heard, tune the all-wave generator to 33.75 megacycles, which is one-quarter of 135 megacycles. This will produce another signal in the receiver if it is actually tuned to 135 megacycles. Assuming all is well, reset the all-wave oscillator to 45 megacycles and mark the calibration point on the u.h.f. signal generator. After this point is spotted set the all-wave generator to 46 megacycles and mark the 138 megacycle harmonic. Repeat until the maximum frequency of the low-frequency generator is reached. If it tunes to 60 megacycles, calibration points will be available to 180 megacycles. Leave the receiver set at 180 megacycles and retune the all-wave generator to 45 megacycles. Its fourth harmonic will then be heard in the receiver. Repeating the previous process, calibration points will now be available up to 240 megacycles. The fifth harmonic of 48 megacycles is 240 megacycles, so next set the all-wave generator to that point. Once again, repeat the routine. Do this until the harmonics are too weak to use.

When usable output is no longer available from the all-wave generator, harmonics of the previously calibrated frequencies on the u.h.f. generator are used. The method is this: assuming that the last calibrated point was 300 megacycles, the receiver is left on that frequency and the u.h.f. generator is tuned to 150 megacycles. The second harmonic will then be heard in the receiver. Now tune the generator to a slightly higher frequency, say 152 megacycles. Tune the harmonic in on the receiver. Without touching the receiver, the generator is tuned higher in frequency until it can again be

Fig. 9. Mechanical details of the cabinet.

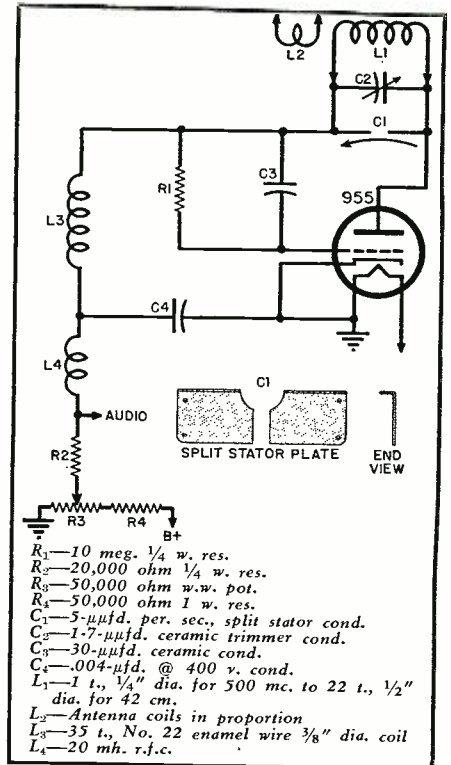
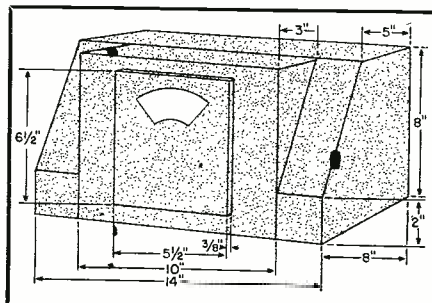

Fig. 8. Suggested circuit for a superregenerative detector suitable for use in calibrating the u.h.f. signal generator. C<sub>1</sub> consists of a single rotor plate and bearing taken from a Cardwell midget condenser, and a split stator plate made from a piece of aluminum as shown in the sketch. The whole unit is mounted on a polystyrene block about 4" square. The coils are fastened directly to the stators by means of small screws tapped into the plates. Small lugs are soldered to the coils for terminals. On the lower frequencies (up to approximately 300 mc.) tuning is done with the 1.7 μfd. trimmer, adjusted with a neutralizing tool, and C<sub>1</sub> used for fine adjustment. Above 300 mc., C<sub>2</sub> is removed and all tuning done with C<sub>1</sub>.

heard. The u.h.f. oscillator will then be on 304 megacycles, and the point marked. By repeating this process of spotting the second harmonic of a calibrated frequency of the u.h.f. generator and then tuning the generator to the receiver, the calibration curve can be completed.

Errors in plotting the first points will be magnified each time a higher harmonic is used, so great care must be taken in reading and setting dials. Once this initial calibration is finished the accuracy of calibration can be checked with the harmonics of crystal oscillators. A preliminary calibration is necessary before the harmonics of low-frequency equipment can be used, because otherwise it is impossible to identify the proper one.

There it is: a continuously variable signal generator tuning from 135 to 465 megacycles with a trifle more output on the highest frequencies than on the lower ones, or a range of from 135 to over 500 megacycles with a slight reduction in output on the highest frequencies.



# THE PROS AND CONS OF HERMETIC SEALING

**HERMETIC SEALING**—A wondrous process which was a government "Must" when ordering Transformers and Reactors for war use. At that time we could take no chances on faulty equipment that might seriously hinder military operations and inadvertently cause unnecessary loss of life among our fighting men.

**EXPENSIVE**—yes, but added costs meant little when the only thing really important was winning the war.

**IN PEACE**—we at KENYON are of the opinion that such expense is not warranted. Past performance of ordinary transformers shows conclusively that sealing in a metal case with humidity proof compound along with proper mechanical design is sufficient. This conclusion is self-evident if you will weigh all cost factors involved.

**SMALL AUDIO-COMPONENTS**—KENYON has developed a range of case sizes (illustrated) which are adaptable to Hermetic Sealing and also to a new exclusive KENYON PROCESS. Despite the fact that the danger of moisture damage is greater in the small audio-component, we feel that our exclusive KENYON PROCESS is more than adequate. While it does not make 100% of the units proof against a five-cycle test, it does make all units impervious to salt water immersion over narrower temperature ranges—and is very much less expensive.

The saving involved by this new Process is so substantial that the cost of the few replacements that might be saved by Hermetic Sealing is more than offset by this much lower original cost.

The items illustrated are only a few of the many possibilities offered by KENYON. We will be more than happy to supply complete details on request.

*Write Now For 1945  
Illustrated Catalog*



THE MARK OF

EXCELLENCE

**KENYON TRANSFORMER CO., Inc.** 840 BARRY STREET  
NEW YORK, U. S. A.



# Everything FOR THE SERVICE DEALER

We have, ready for immediate delivery, a complete stock of tools, replacement parts, inter-communication systems, public address systems, test equipment . . . everything in radio equipment for the progressive service dealer. For big profit items . . . for quick delivery . . . place your order now with Leo.

## 6 TUBE AC-DC KIT

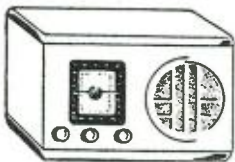

Complete, ready for assembly.

**\$23.75**

Cat. No. 7-691

A two-band, superheterodyne kit with all tubes, speaker, chassis, and all parts for easy assembly. Broadcast band from 540 to 1620 KC. Short wave from 5.7 to 18.3 MC. Cabinet, \$5.25.

## WRL MULTI TESTER

All purpose tester. Money back guarantee.

**\$18.75**

less leads

Cat. No. 16-439



Handles AC DC Voltmeter, DC Milliammeter, high and low range Ohmmeter. 3" meter with sturdy D'Aronsva movement. Size 5 1/2 x 8 x 3 1/4"

Exclusive at WRL!  
Our latest flyer  
12 page V-J edition of merchandise and radio values. FREE.  
Handy Tube-Base Calculator . . . 25c  
Giant Radio Reference Map, 3 1/2 x 4 1/2 ft. . . 15c



### MAIL TODAY RN-1

Wholesale Radio Laboratory  
744 West Broadway Council Bluffs, Iowa

- Rush \_\_\_\_\_ WRL Multitesters. Cost, \$ \_\_\_\_\_
- Send \_\_\_\_\_ 6-tube AC DC Kits and cabinets. Cost, \$ \_\_\_\_\_
- I want a tube-calculator. 25c enclosed.
- Ship me your radio map. 15c enclosed.
- Send me your new V-J Flyer free.

Enclosed is \$ \_\_\_\_\_; Balance C.O.D.

Name \_\_\_\_\_

Address \_\_\_\_\_

Town \_\_\_\_\_ State \_\_\_\_\_

I am  an amateur;  experimenter;  service man.

We invite industrial inquiries for electronic equipment and devices of all kinds.

**QUICK SERVICE FROM LEO**  
"same day" delivery service from the heart of the nation . . . on anything in radio. Order today.



**Wholesale  
RADIO LABORATORIES**

# LETTERS FROM OUR READERS

## SUGGESTIONS

**I**N THE September issue of your valued magazine in which Mr. Willoughby favors only the licensing of radio servicemen and women holding a diploma from some school I certainly do not agree with Mr. Willoughby.

"My experience in the radio field dates back to 1916, on up to the present day. I have seen many graduates holding a diploma who did not even learn the simple color codes, much less the theory of radio. I can point out any number of such so-called graduates that would be licensed but had never made a clean solder joint.

"Just where does Mr. Willoughby get the belief that radio schools should be the higher up in determining a man's fitness for license?"

"Why not license servicemen and women according to training, experience, and necessary tools and test equipment to do a decent repair job?"

"Let's hear from some of the older radiomen with fifteen or twenty years or more experience.

"Yours for better service work."

Irving G. Couvillion, Sr.  
Marksville, La.

\* \* \*

**I** WOULD like to reply to Major Ed. M. Hoskinson whose letter appeared on Page 144 of the October issue of RADIO NEWS.

"In his selection of a serviceman, he has said he wanted one who specialized in one brand of radio, namely his own. I would like to have the good Major shown a complete set of Rider's Manuals which, as most of us know, constitute a most monumental piece of work in gathering and assembling facts concerning every radio made. Unless the serviceman is a factory representative and is maintained in the field by the factory he cannot afford to specialize.

"I have no place in my organization for the specialist and neither does Puget Sound Navy Yard where I work. I repair RCA, Bogen, Western Electric, Executone sound systems aboard warships of the U. S. Navy, and I couldn't hold down my job if an RCA job came in and I said 'I specialize on Western Electric equipment.' As to the squawkers about service trained radiomen getting in the business, O.K. let them come. The really good ones will be there pitching because they would have been there, army training or no army training. You can't hold a good man down. I'm not going to fight GI Joe for a job. I'm going to help him if I can. Why? Because brothers he saved my neck by getting shot at and suffered instead of me, and I appreciate that no end. So, if some Joe gets my job because I'm not a veteran, well he earned it. No really competent

serviceman will worry about competition. His customers know him and know his ability. GI Joe will build up his clientele also and there's enough for all who play the game square. I agree on neatness and a pleasant personality. I always try to please my customers at my own shop and give them the most for their money. I've repaired radios for over twenty years, the last ten in this community and I like my neighbors and they like me. If I cheated them or put in second grade material, they would soon find it out.

"Good-will isn't sold over counters, but it is in the little human relations between a serviceman and his customer. A serviceman's education just starts with a technical education, Major, and I do hope the Army taught those boys 'How to make friends and influence people.' That is necessary in successful business dealings. I could go on for hours here on my pet subject."

W. A. Ritchie  
Bremerton, Washington

\* \* \*

## STRIKE ISSUE

**J**UST received my November 1945 RADIO NEWS. It's one of the best you have ever published. I have had RADIO NEWS either by subscription or newsstand for many years and I certainly enjoy the items.

"But, the tops to me is Board's Short-wave pages. That is the best crowd of stations and times for the reception I have ever seen . . . This item alone is well worth the price of subscription. Keep it going."

Charles G. Shaffer  
Buffalo, N. Y.

\* \* \*

## NATIONWIDE ORGANIZATION

**I** HAVE read the various arguments and articles in RADIO NEWS regarding licensing radio repairmen, and here is my answer to them all. If the fellows in the business would spend more time learning more about radio so they can do an even better job than before, and less worrying about the beginners and tinkers, they will find plenty of work coming their way. The public is quick to find out who the serviceman is in the community that can do a real job on their radio.

"With over twenty years' experience in radio service I find plenty to learn and study about in radio and electronics. Knowing how and doing all of the work right brings the customers, and their advertising of your work travels far and wide.

"Instead of licensing we should think more of a non-union radio servicemen's nationwide organization that would enable us to throw some weight around when we need, such as now in





The Old "97" was born 50 years too soon!

**THAT FAMOUS OLD WRECK WOULD NEVER HAVE OCCURRED WITH MOTOROLA RIDING IN THE ENGINEER'S CAB...**

Not only does Radiotelephone add new safety to modern railroading, it greatly increases the efficiency of almost every phase of operation. Now, engineers, conductors and train dispatchers are in constant contact with each other for split-second action at all times. In everyday routine railroading as well as in emergencies, Motorola F-M 2- and 3-way Radiotelephone pays big dividends in safety, economy and efficiency.

It is significant that the first Federally licensed railroad radio used Motorola equipment exclusively. Motorola is an experienced hand at mobile communications equipment. Highway police of 34 states, railroads, public utilities and many other public service agencies depend on Motorola for 2-way communication. Ask Motorola engineers to show you how F-M Radiotelephone can increase the efficiency of your operation. Write today!



**GALVIN**

**MFG. CORPORATION • CHICAGO 51**  
COMMUNICATIONS AND ELECTRONICS DIVISION

F-M & A-M HOME RADIO • AUTO RADIO • AUTOMATIC PHONOGRAPHS • TELEVISION • "HANDIE TALKIES" • POLICE RADIO • RADAR



## Radiomen's Headquarters BUFFALO RADIO SUPPLY

219-221 Genesee St., Dept. N

Buffalo 3, N. Y.

All Kinds of Radio Tubes in Stock  
at Best Wholesale Prices

Mail in your orders for all types needed,  
not just the critical numbers, and we'll try  
to fill them completely !!!

### All Ballast Tubes \$37

Gold-Plated Single Button Midget Carbon Micro-  
phone with stretched duraluminum diaphragm.  
Works in any position. Made for Signal Corps.  
Perfect for label mike or concealed or secret pick-  
ups. Super Special \$9.95.

7 Asst. I.F. Transformers in Aluminum cans—  
\$1.98; 5 Asst. Unshielded Oscillator Coils—\$.69;  
Bakelite A.C. Plugs per 100—\$2.00; Spring Ac-  
tion Cube Taps per 12—\$1.00; Sensational Speedex  
Wire Stripper that cleans solid or stranded wire  
instantly at rate of 1000 ends per hour—\$3.52;  
General Electric 2000 ohm per volt 3½" founda-  
tion meter with ohms and volt scales—11.00; 66"  
highest grade standard type 3 section car aerials  
—1.10, with low-loss lead—1.50.

Bargains in Steatite Air-Tuning Condensers with  
¾" shafts. Regularly \$1.30 to 2.25. Shaft length  
indicated: 25 MMF. ¼"—.39; 50 MMF. ¼"—  
.39; 50 MMF. ½"—.49; 75 MMF. ½"—.49; 100  
MMF. ½"—.54; 140 MMF. ½"—.69.

Chassis cradles to support your work on the bench  
without danger of damage to coils, etc. Work can  
be rotated and locked in position at any angle—  
\$.49.

Webster Record Changers in the new post-war  
model. One of the finest and most fool-proof  
changers we have ever seen. Immediate deliv-  
ery. \$35.95.

Bullet Crystal Mikes—5.45. Bullet Dynamic  
Mikes—7.45.

Highest Grade Signal Corp 2000 ohm headsets  
with real leather bands and sponge rubber car-  
diads—\$1.95; Crosley switches with D.P.S.T. &  
S.P.D.T. sections, perfect for phono-radio switches.  
2 for \$.25. Heavy Brass Binding Posts—.03.

### 115V. 60 CYCLE HALF-SHELL POWER TRANSFORMERS

4 or 5 Tube Sets, 650V, 40 MA. HT., 5V Fil. and either 6.3 or 2.5 Fil.	\$1.40
5 or 6 Tube Sets, 650V, 45 MA. HT., 5V Fil. and either 6.3 or 2.5 Fil.	1.55
6 or 7 Tube Sets, 675V, 50 MA. HT., 5V Fil. and either 6.3 or 2.5 Fil.	1.70
7 or 8 Tube Sets, 700V, 70 MA. HT., 5V Fil. and either a 6.3 or two 2.5 Fil.	2.05
9 to 11 Tube Sets, 700V, 100 MA. HT., 5V Fil. and either a 6.3 or two 2.5 Fil.	2.75
Filter Chokes, Cadmium Plated Straps, 2" Mounting, 200, 300, 400 or 500 ohms.	.49

**AUDIO TRANSFORMERS:** 1 Plate to Single Grid,  
5:1, \$.69; 1 Plate to Push-Pull Grids, 3:1, \$.69;  
Universal Output Tapped for Various Impedances,  
\$.79; Single or Double Button Mike Transformers,  
\$.69.

Condensers guaranteed 1 year. Prices in Lots of  
100, either 1 type or asst. 100. Mfd. 25V—.35; 50  
Mfd. 150V—.45; 20-30 Mfd. 150V—.40; 20-30  
Mfd. 150V—.30; 25 Mfd. 25V—.20; 10-10 Mfd.  
450V—.45; 20 Mfd. 150V—.20; 16 Mfd. 450V—.40;  
12 Mfd. 150V—.15; 10 Mfd. 450V—.27; 10  
Mfd. 50V—.15; 8 Mfd. 450V—.23; 25 Mfd. 600V—.08;  
12 Mfd. 600V—.10; .05 Mfd. 600V—.09;  
.02 Mfd. 600V—.08; .01 Mfd. 600V—.08; .008  
Mfd. 600V—.05; .005 and all smaller capacities in  
600V rating—.07 each;

### FAST SERVICE

LOWEST PRICES • COMPLETE STOCKS

**LEWIS ENGINEERING SCHOOL**

Correspondence Courses in  
**RADIO and ELECTRICAL ENGINEERING**

**ELECTRICAL ENGINEERING** Get good  
electrical field. Prepare yourself at Low Cost, for secure  
future. Modern course. So simplified anyone can understand quickly.

**RADIO ENGINEERING** Extra fine course in radio, public  
address, photo-electric work; Trains  
you to be super-service man, real vacuum-tube technician. Services  
needed badly. Diploma on completion.

**WRITE** Send postcard or letter for Free  
Copies of school catalogs, full  
details, all about deferred pay-  
ment plan, etc. **LOW \$25** Either  
AS Course

LINCOLN ENGINEERING SCHOOL, Box 931-R85, Lincoln 2, Nebr.

**FILMGRAPH PATD**

## Conference Recorders

UNINTERRUPTED  
Longtime (up to 12 hours) Conference  
& Telephone Recordings on Safety Film  
Models for Dictation "TALKIES"

ECONOMICAL  
PERMANENT  
INSTANTANEOUS  
PLAY-BACK

MILES REPRODUCER CO., INC. 812 BROADWAY, N.Y.3 RN-1

regards to the way the tube manu-  
facturers have been treating us since  
the end of the war. We all patiently  
went without tubes during the war,  
but now the radio set manufacturers  
are getting almost all the tube  
output since the very beginning of  
peace and they knew production could  
not be in full swing for at least two  
months . . . If the radio servicemen  
could have had the full tube produc-  
tion for that two-month period there  
would be less sets inactive at the pres-  
ent time and our pockets would jingle  
a little louder. With a nation-wide  
organization we could have a chance  
to help ourselves. What do you fel-  
lows think about this idea?"

Thomas H. Bell  
North Attleboro, Mass.

-50-

## Transmitter—28-54 Mc.

(Continued from page 42)

multi-stage transmitter, it usually is  
switched-in to read plate currents.  
Plate current indications in quadrup-  
lers are not so reliable, however, since  
plate current variations resulting  
from the tuning of these stages tend  
to be mere dimples instead of robust  
dips. A better scheme is to read the  
grid current of a succeeding stage. In  
this case, the meter will take an un-  
mistakable upward swing when the  
previous stage is correctly adjusted.

In the 28-54 transmitter, grid cur-  
rents are read in each instance ex-  
cept when plate current of the 815 is  
checked also. The 0-1 d.c. milliam-  
meter, *M* actually is employed as a  
voltmeter to read the drops produced  
across low-value resistors by the flow  
of the grid or plate currents. Thus,  
when meter switch *S*<sub>2</sub> is in position 1,  
the meter is actuated by the drop pro-  
duced across a 100-ohm resistor, *R*<sub>6</sub>,  
by grid current of the second 7C5  
tube. An upward swing of the pointer  
here indicates that the crystal stage  
is correctly tuned. In this position of  
*S*<sub>2</sub>, full-scale deflection of the meter  
corresponds to 2 milliamperes (for a  
100-ohm meter).

When *S*<sub>2</sub> is at position 2, grid cur-  
rent of the 815 is checked by reading  
the voltage drop across a 100-ohm re-  
sistor, *R*<sub>9</sub>, produced by the flow of  
rectified grid current. In this posi-  
tion, *M* is converted into a 0-½ d.c.  
voltmeter by the 500-ohm multiplier  
resistor, *R*<sub>7</sub>. An upward swing of the  
pointer here indicates correct setting  
of the second 7C5 stage and of the  
815 grid tank. Full-scale deflection  
of the meter, with *S*<sub>2</sub> in this position,  
corresponds to 5 ma.

When *S*<sub>2</sub> is at position 3, the milli-  
ammeter is converted into a 0-2 d.c.  
voltmeter by the 2000-ohm multiplier  
resistor, *R*<sub>11</sub>. Here the meter is actu-  
ated by the voltage drop produced  
across the 10-ohm resistor, *R*<sub>13</sub>, by 815  
plate current. A *dip* of the pointer  
here indicates correct setting of the  
815 plate tank. Full-scale deflection

of the meter in this position of *S*<sub>2</sub> cor-  
responds to 200 milliamperes.

It may appear offhand that consid-  
erable trouble might be expected in  
taking the 815 grid current reading,  
since this deflection of the meter de-  
pends upon the correct setting of two  
tank circuits, *L*<sub>2</sub>-*C*<sub>11</sub> and *L*<sub>3</sub>-*C*<sub>12</sub>. How-  
ever, little difficulty actually is ex-  
perienced if the grid tank is set ap-  
proximately before tuning *L*<sub>2</sub>-*C*<sub>11</sub>, and  
then "trimming" with the grid tank.  
The task is made still easier if the  
transmitter has been pre-adjusted as  
will be explained under *Tuning Up*.

### Power Supply

The power supply components are  
mounted on the left-hand end of the  
chassis where they may be seen in  
Figs. 1, 3, 4, and 5. This is a simple  
arrangement which is no more com-  
plex than the power supply section  
of a home radio and it is of approxi-  
mately the same physical size.

The transformer, *T*, supplies 5 v.,  
6.3 v., and 770 v. (center tapped) at  
180 ma. In operation, the 7C5 and  
815 plates receive slightly more than  
300 volts d.c. The single filter choke,  
*CH*, is rated at 15 henries, 200 milli-  
amperes d.c. A plug-in dual 20-μfd.  
electrolytic filter capacitor, *C*<sub>19-20</sub>, is  
employed. The bleeder, *R*<sub>15</sub>, is a 25,-  
000- or 30,000-ohm, 75-watt vitreous-  
enameled wirewound resistor.

The power-line bypass capacitors,  
*C*<sub>17</sub> and *C*<sub>18</sub>, each are .1 μfd., 600-v.  
tubular components. While a 115-v.,  
6-watt pilot light has been employed  
in the writer's transmitter and has so  
been indicated in Fig. 6, a 6.3-v. lamp  
may be connected between the trans-  
mitter chassis and point "X" of the  
6.3-v. winding of transformer *T*<sub>1</sub>. A  
recessed male power plug is mounted  
on the rear lip of the chassis for in-  
sertion of the line plug and cord. No  
power-line switch was included in the  
transmitter shown, since it was in-  
tended that the line cord be run to  
a central switching panel in the trans-  
mitter rack. However, the individual  
builder may include one if he desires.

### Relay Terminals

The relay terminals (the ceramic-  
insulated through-chassis posts seen  
on the rear lip of the chassis in Figs.  
3 and 4) are in series with the high-  
voltage center tap of transformer *T*<sub>1</sub>  
and ground (chassis). When these  
terminals are short-circuited by a re-  
lay, send-receive switch, or jumper,  
plate and screen voltages are applied  
to the transmitter stages; the voltage  
is removed when these terminals again  
are open-circuited. In this the trans-  
mitter may be shut off during listen-  
ing periods without extinguishing the  
tube heaters.

### Modulator Input Plug

The modulator input plug (See Fig.  
6) admits audio power from an ex-  
ternal modulator unit and applies it  
in series with the d.c. power supply  
and plate-screen circuit of the 815.  
The modulator input plug is mounted  
on the rear lip of the chassis (See



# *The Curtain is Rising*

on the most sensational development, hitherto undreamed of, in amateur radio history! There isn't a "ham" operator in the United States, or in the entire world for that matter, who won't be interested in knowing what is behind this curtain. Watch for the Kluge advertisements to follow.

The Kluge secret will soon be  
a reality



1031 N. ALVARADO • LOS ANGELES 26, CALIF.

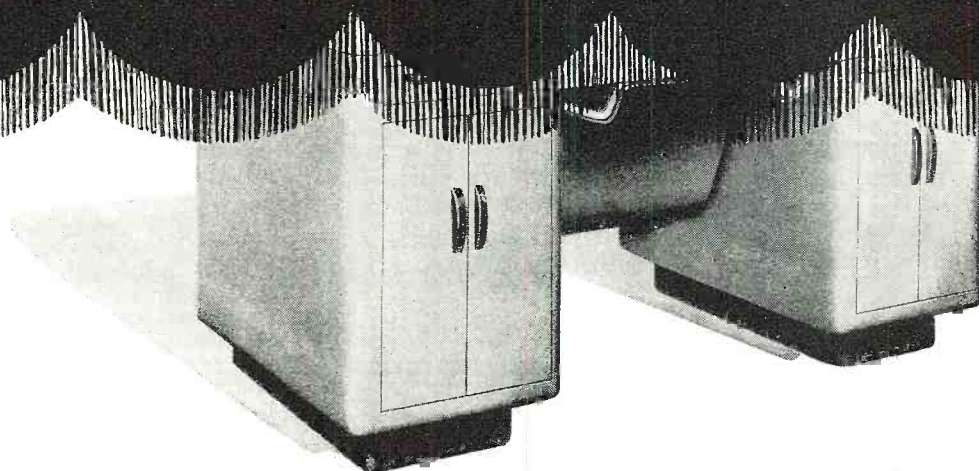



Figs. 3 and 4) and the companion socket is attached to the modulator output cord. When modulation is not employed, an identical socket having its terminals connected together by means of a jumper must be inserted in the plug to complete the 815 "B+" line. The sockets and plugs shown in the illustrations are Jones type 5402 CCT and P402 AB components.

### Assembly and Layout

Although the top views of the transmitter would seem to reveal a lot of "breathing space," the underchassis photographs (Fig. 5) show that every available square inch of space has

been utilized. Each component has been placed in its most efficient electrical position—that is, where shortest leads might be obtained.

Top views are available in Figs. 1 and 4, rear views in 3 and 4, and details in Figs. 4 and 7.

The *excitability* of the 815 demands that the final amplifier plate tank be mounted above the chassis and the grid tank underneath. Furthermore, all of the exciter tank likewise must be mounted below chassis. In order to complete the job of shielding and to discourage self-oscillation in the final amplifier, the 815 is mounted through a  $2\frac{1}{16}$ "-diameter clearance hole in the chassis to such a depth

that the shield pan inside the tube is level with the top of the chassis. In order to place the 815 correctly, its special *large wafer* octal socket is mounted on a  $2\frac{1}{2}$ "-square steel plate supported below the chassis by means of four *heavy brass* studs (at least  $\frac{3}{8}$ " in diameter). This arrangement is illustrated in Fig. 7.

Although there is good separation between the coils,  $L_1$ ,  $L_2$ , and  $L_3$  are mounted at right angles to each other.  $L_1$  is mounted upright on a small ceramic insulator  $\frac{3}{8}$ " in diameter and  $\frac{1}{2}$ " long.  $L_2$  is mounted directly on one of the threaded stator rods that extend in the back of tuning capacitor  $C_{11}$ . The ends of  $L_3$  are soldered directly to the stator lugs of tuning capacitor  $C_{12}$ . The form on which the link winding of  $L_3$  is wound is supported from the back lip of the chassis by means of a long threaded rod. Each of the tanks just described may be seen clearly in the closeup photograph, Fig. 5. At upper left is seen the  $L_2$ - $C_{11}$  combination. The  $L_1$ - $C_4$  combination is seen at left center. And the 815 grid tank,  $L_3$ - $C_{12}$  is at lower right. Directly above the grid tank, and at right center, is the recessed plate holding the 815 socket. Here may be seen clearly the studs supporting the plate, and the 815 socket wiring.

The tuning capacitors are mounted close to the tubes with which they are associated. This places each tuning unit some distance back of the front panel. Long shafts extend from the tuning dials on the panel to the variable capacitors in the rear. Quarter-inch bakelite rod, passing through panel bushings, is run from each dial and is joined to a capacitor shaft by means of a flexible coupling. Each variable capacitor is supported from the chassis by a pair of  $\frac{3}{8}$ "-diameter ceramic standoff pillar-type insulators. It perhaps would be more advisable, however, to support  $C_{12}$  and  $C_{13}$  on  $\frac{3}{8}$ "-diameter brass studs, in order to obtain a low-inductance ground to the capacitor frames and rotors.

The polystyrene crystal sockets,  $X_1$  to  $X_4$ , are mounted in a straight line on top of the chassis along the right-hand front edge, directly behind the panel. Crystal selector switch  $S$ , is mounted under the chassis close to the crystal sockets. Its shaft bushing extends through the panel and its finger-grip knob may be seen between the two lower left-hand dials in Figs. 1 and 4.

Mounted along the back of the chassis (See Figs. 3 and 4) are the coaxial output jack, relay terminals, modulation input plug, and power-line socket.

For support, heavy-gauge steel brackets extend on each end from the top of the panel to a point on the chassis about  $4\frac{1}{2}$ " behind the panel.

Mechanical construction of the transmitter is not difficult, nor is it unconventional in any way. The usual rules of sturdy construction must be applied throughout in the interest

## SPEED UP REPAIRS WITH THESE G-C AIDS!



**FREE STEEL CABINET**

**G-C Dial Belt Kits**

Every Serviceman needs a G-C Dial Belt Kit. Save money—be ready for that repair job. Finest woven fabric replacements. Easy to install—no stretch—no adjustments. Supplied in kits of 25, 50, 100, 200 or 300 Belts in sturdy metal box with slide-in drawer. Free Belt Guide and measuring device.



**G-C Radio Service Cement**

The best Cement for Speaker and Radio Work. Especially suitable for cementing replacement cones and repairing rattling and torn cones. Also used on glass, to seal adjustments, hold wires in place, etc. Dependable, vibration proof, water-proof and fast drying.



**G-C Dial Drive Cables**

G-C has a complete line of Dial Drive replacement cables. Available by the spool for prompt servicing of all sets. Every Serviceman should have a complete assortment. Best quality—extra strength. Preferred by Radio Men everywhere.

Write for New G-C Catalog No. 146 and G-C Dial Belt and Service Book

Immediate Delivery on all G-C Products

Order From Your Radio Parts Jobber

ALWAYS ASK FOR G-C PRODUCTS

GENERAL CEMENT MFG. CO.  
ROCKFORD, ILLINOIS

# UNIVERSAL

## Model 501

# RADIO TUBE TESTER

Advanced Styling — Finest Quality Materials and Workmanship.

Designed to give lasting service and priced to **SAVE YOU MONEY.**

WRITE TODAY for SPECIFICATIONS and PRICES.

---

Please rush me full details and specifications on UNIVERSAL Radio Service Instruments.

Name.....

Street.....

City.....

**PRECISION ELECTRONIC INSTRUMENTS**



UNIVERSAL INSTRUMENT CO.
CINCINNATI 19, OHIO

306 E. McMILLAN STREET



LET US BE YOUR  
DEPENDABLE SOURCE FOR

*Radio-  
Phonograph* **Pick-up**

**CORDS**

*Runzel*  
CORDS · WIRES CABLES

**RUNZEL CORD & WIRE COMPANY**  
4721 MONTROSE AVENUE • CHICAGO 41, ILL.



Available Immediately  
PORTABLE, 2 WAY  
**RADIO TRANSMITTER  
AND RECEIVER SETS**

No. 5CR-583



**COMPLETE with War Dept. Manual  
and READY TO OPERATE . . .**

For pack, vehicular or ground operation. Entirely waterproofed; can be operated in driving rain. Power output up to 40 watts. Distance range to 80 miles. 12 Transmission Bands, Frequency range from 2.2 to 4.6 mc. Receiver 2.2 to 4.6 mc.

Government paid \$1775 for set . . .  
**OUR PRICE while quantity lasts**

**\$215<sup>00</sup>**

Plus Crating  
F. O. B. Chicago

**EQUIPPED WITH**

- Radio Transmitter and Receiver Set with Tubes
- Accessory Chest
- Antenna and Roll Bag
- Power Unit and Power Converter Unit
- Mast Bracket
- Head Sets
- Built-in Speaker
- Microphones
- Hand Sets
- Plugs
- Cables
- Code Key

**LEONARD ASHBACH**  
*Company*

**ELECTRONICS DISTRIBUTORS**  
Phone WHitehall 2065  
152 W. HURON ST. • CHICAGO 10, ILL.

**RADIO COURSES**

- RADIO OPERATING
- RADIO SERVICING — ELECTRONICS
- REFRIGERATION SERVICING

Personal Counselling Services for Veterans  
Write for Latest Trade & Technical Catalog  
**Y.M.C.A. TRADE & TECHNICAL SCHOOLS**  
7 W. 64th Street New York City

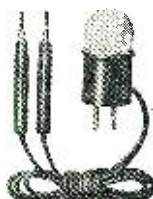

**PLUG-IN TEST LAMP**

Tests Everything Electrical  
Speeds Up Trouble-Shooting

Used by Radio Men, Electricians, Mechanics and Experimenters. Tests continuity, open circuits, etc. ALWAYS READY! PLUGS INTO ANY OUTLET! Only \$1.50 Postpaid. FREE CIRCULAR. (Pat. Pend.) **HANLAN CO., 1419-R, West Jefferson, Los Angeles 7, Calif.**

of electrical stability. All components must be mounted as closely as possible to all other components with which they are connected. Thus, all capacitors, resistors, and coils associated with a particular tube must be mounted close to that tube socket. Capacitors  $C_1$ ,  $C_6$ , and  $C_{16}$  should be mounted with their broad, flat faces perpendicular to the chassis to reduce capacitance to ground.

In all u.h.f. equipment, especially that containing wide-range tuned circuits, every precaution must be taken to prevent mechanical shifts and bending of the chassis and panel which will alter the positions of components, thereby causing capacitance shifts. For this reason solid construction must be employed in the 28-54 transmitter. Panel and chassis must be bolted solidly. Use no flimsy components. Terminal strips (insulated lugs), wire, and cable clamps should be used liberally in the assembly.

**Wiring**

Use of the shortest possible leads is the order of the day in all high-frequency equipment. In wiring in a single stage in the 28-54 transmitter, the tube socket is a logical nucleus. In each stage, capacitors, chokes, resistors, and other components may be connected directly to the prongs of the tube socket.

The efficiency of each of the three stages is increased markedly by soldering all "ground returns" for that stage to a single point on the chassis. This point conveniently may be a grounded blank prong on the tube socket. In the 7C5 stages, socket terminal 4 or 5 may be used. In the 815 stage, socket terminals 3, 5, and 6 must be connected together and grounded to chassis, so either one of these contacts may be used as the common return.

Regular hookup wire is employed in the "long" wiring of the transmitter. However, "B+" leads in the 815 stage must be wired with hookup wire having heavy insulation to guard against breakdown to chassis on modulation peaks. Rigid wire is recommended for crystal socket and crystal switch wiring. No. 14 busbar must be employed between the 7C5 plates and the high end of the corresponding plate tanks, between the two stators of  $C_{12}$  and the 815 grids, and between the two stators of  $C_{15}$  and the plug-in plate coil base. Heavy, rubber-covered, stranded wire is run from the 815 plate tank to the top-cap plate terminals of the tube. Safety (insulated) cap connectors are employed. Heavy, rubber-covered, stranded wire also is run from the milliammeter terminals to the meter switch. The twisted pair link-coupling line between  $L_2$  and  $L_3$  is made of heavy hookup wire with thick insulation run close to the chassis and held to the latter by soldering lugs bent to form miniature cable clamps. But the line running from the link coil on  $L_4$  to the output jack,  $J$ , is a short length

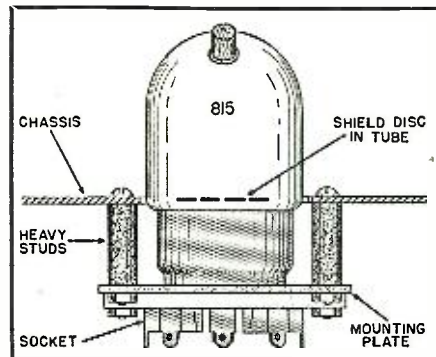

Fig. 7. Mechanical assembly of recessed 815 final amplifier tube.

of low-loss, low-impedance coaxial conductor.

In wiring the 815 socket, the heater terminals are arranged for 6.3-volt operation by connecting together terminals 1 and 8, and using 1 and 5 as the heater connections. Terminals 3 and 6 also must be connected together at the socket.

**Tuning Up**

Before attempting the initial test of the transmitter, be sure to check carefully all wiring and mechanical assembly. Proceed with the tuning-up operations (described below) only after a complete inspection shows all wiring correct and reveals no loose parts.

(1) Open the 815 plate-screen circuit by removing the special shorting socket from the modulation input plug on the back of the chassis.

(2) Connect a jumper between the relay terminals on the back of the chassis.

(3) Throw the crystal switch  $S_1$ , to connect into the circuit a crystal or very near 7000 kc.

(4) Throw the meter switch,  $S_2$ , to position 1.

(5) Insert the 115-volt power-line plug into the rear-chassis socket and allow a few minutes for the tube heaters to come up to normal operating temperature.

(6) Starting at the high-capacitance setting of  $C_4$ , tune this capacitor slowly. Shortly after leaving the maximum-capacitance end of the range, the milliammeter will be deflected sharply upward. At the peak of this swing, tank circuit  $L_1-C_4$  is correctly adjusted to the crystal frequency. As the tuning of  $C_4$  is continued further in the direction of minimum capacitance, another upward swing of the meter will be noted at the opposite end of the dial. At the peak of this swing, tank circuit  $L_1-C_4$  is correctly adjusted to the second harmonic of the crystal frequency. It will not be necessary to record the two dial readings, since the first 7C5 stage will give only two such meter deflections (fundamental and second harmonic) with any crystal, and it will be possible to distinguish one from the other simply by noting whether the peak occurs at the high or low end of the dial.



# This simple little lapel button is the mark of a great service

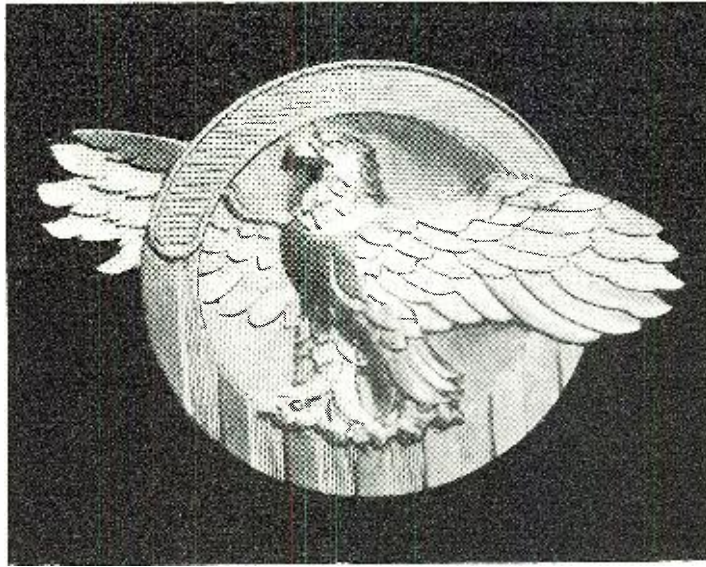

***It means that the wearer has received  
an honorable discharge from the  
armed forces of our country***

All men and women honorably discharged from the armed services of the United States of America—and there will be 13,000,000 of them—are entitled to wear this button.

It is the symbol of a service for freedom and humanity of which we are all proud—of a sacrifice for which we are all grateful.

America will not forget what they have done. To recognize this emblem, and to give the wearer the respect and consideration which is his due, is our first responsibility. The uniforms have been laid aside, but heroic achievements are epitomized in these little pins. We can do our part to make the welcome home genuine and lasting. We are determined that their service shall not be in vain.



**ZIFF-DAVIS PUBLISHING COMPANY**

*Publishers of*

POPULAR PHOTOGRAPHY ★ PLASTICS ★ RADIO NEWS ★ FLYING ★ INDUSTRIAL AVIATION ★ RADIO ELECTRONIC ENGINEERING

January, 1946

125



# 5" OSCILLOSCOPES

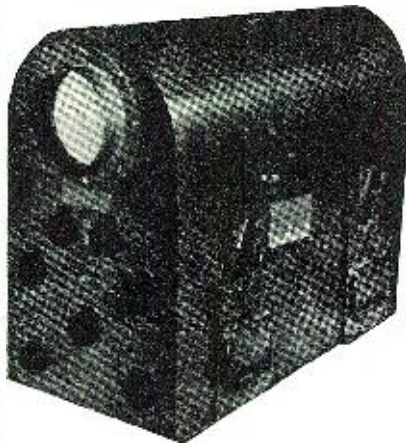

**FROM GOV'T RADAR SCR268  
WESTERN ELECTRIC MANUFACTURED  
AT A PRICE YOU CAN AFFORD**

GOV'T COST \$44.95  
APP. \$500 WITH ALL TUBES

- 5" 5BP4 Cathode Ray Tube
- Vertical and horizontal positioning controls
- Intensity control
- Focusing control
- Sweep control
- Horizontal amplitude control
- 2500 volt and 400 volt power supplies
- 115 V 60 cycles
- 2 x 2 and 5T4 rectifiers
- One 6AC7 pulse amplifier
- Two 6SJ7 amplifiers
- 6L6 amplifiers

**10,000 SQ. FT. COAXIAL WIRE  
G.E. MAKE, 10c PER FT.**

## SPECIAL

### SIGNAL CORPUS SURPLUS (Almost New)

Lip Mikes	2.00
Throat Mikes	.80
10,000 imp. pair Head Phones	1.75
Telegraph Keys	1.00
Receivers Super Hets. from Radar are	
268 110 V operation with Acorn Tubes in RF tunes 190-210 meg. band band with 15 tubes	29.95
5" BFI Oscilloscope Tubes	13.50
<b>ALL ITEMS TESTED</b>	
GE Pyranol 8 mid 600 V. W.	1.85
GE Pyranol 10 mid 600 V. W.	1.95
Transformers Kenyon 2.5 V. 10 amps. (5000 V. insulation) 110 V. Pir.	
Federal 500 Watt Transmitter complete 110 V. operation C.W. (grid mod phone)	1150.00
Radar SCR 268 Components W. E. mfg'd BC409 Keyers Complete	59.50
BC407A High powered Oscillator 5kW with 16 tubes 205 megacycles.	99.00
Rectifier High Voltage supply 15000 V. 500 mills DC-110 V. operation	499.00
BC425 Modulation unit	99.00
BC436B Range unit	29.00
Detailed information on request.	

All prices F.O.B. New York City. 25% deposit. Crating and shipping charges added. Send for our Free weekly flyers.

Mail Orders Promptly Filled

**WORLD WIDE COMMUNICATIONS EQUIPMENT**

88 Cortlandt St., N. Y. City  
350 Pearl St., Brooklyn, N. Y.

## PLASTIC RADIO CABINETS TO YOUR ORDER— GOODCHILD PLASTICS CO.

1603 1/2 S. WESTERN AVE.  
LOS ANGELES 6, CALIF

## RADIO ENGINEERING I

EX-SERVICE MEN can complete work here in shortest possible time Special Prep Dept. Also Refresher Courses. Courses also in Civil, Electrical, Mechanical, Chemical, Aeronautical, Engineering; Business Administration, Accounting, Secretarial, Science. Tuition, living costs low. 83rd year. Cosmopolitan student body. Enter Mar., June, Sept., Jan. Catalog. **TRI-STATE COLLEGE** 1616 College Ave. ANGOLA, INDIANA

DEGREE IN 27 MONTHS

(7) Leaving  $C_1$  set to the 2nd harmonic of the crystal frequency, set  $C_{11}$  to its maximum capacitance position, and hold one terminal of a 1/4-watt neon lamp to form contact with the plate end of  $L_2$  or  $C_{11}$ . As  $C_{11}$  then is tuned slowly toward minimum capacitance, the neon lamp will glow sharply at several points, usually four or five, indicating harmonics of the crystal frequency. These will be 4th to 8th harmonics. If a 7-mc. crystal is being used, the harmonic points thus noted (starting from the maximum-capacitance setting of  $C_{11}$ ) will be 28, 35, 42, 49, and 56 mc. Only the 28-mc. point is useful for amateur operation; the other four must be avoided. If a 6250-kc. crystal is being used, the harmonic points indicated will be 31.25, 37.5, 43.75, and 50-mc. In this case, only the 50-mc. point will be useful for amateur operation, and the lower three must be avoided. It will be seen that other crystals in the frequency range 6250-7425 kc. will yield other useful points either in the 28-29.7- or 50-54-mc. band. *The dial settings of  $C_{11}$  corresponding to each of these harmonic points must be recorded (for each crystal employed in the transmitter) in order to facilitate future tuning.*

If the coil and tuning capacitor specifications given in Fig. 6 have been followed exactly, the harmonic points in the tuning range will correspond to the frequencies just mentioned. If there has been any deviation whatever from the Fig. 6 values, it will be necessary to verify the harmonic points with an accurately calibrated absorption wavemeter.

(8) Leaving  $C_{11}$  set to 28 mc., and with  $C_{12}$  set to its maximum-capacitance position, throw meter switch  $S_2$  to position 2. As  $C_{12}$  then is tuned slowly toward minimum capacitance, a sharp upward swing of the milliammeter will indicate that the 815 grid tank,  $L_3-C_{12}$ , has been tuned correctly to 28 mc. Next, set  $C_{11}$  to 54 mc. (or to the highest frequency in the 50-54-mc. band afforded by available crystals on 6250-7425 kc.) and tune  $C_{12}$  until a sharp upward swing of the milliammeter indicates that the 815 grid tank is correctly tuned to 54 mc. To check at 56 mc., use 7-mc. crystal, tune  $L_1-C_1$  to 14 mc., tune  $L_2-C_{11}$  to 56 mc., and tune  $L_3-C_{12}$  to 56 mc. When  $C_{12}$  is tuned in any case for peak deflection, it may be noticed that "touching up" the setting of  $C_{11}$  will increase the peak reading. This is because the  $C_{11}$  points were taken originally with the neon bulb in the circuit. *The grid tank tuning must be checked at every harmonic point (desirable and undesirable) for each available crystal, and each dial setting must be recorded to facilitate future tuning.*

(9) With the milliammeter reading 815 grid current, as described in (8), insert the 10- or 5-meter coil,  $L_4$ , into the plate circuit (insert whichever coil corresponds to the frequency setting of  $L_2-C_{12}$ ) and slowly tune  $C_{15}$ , watching the milliammeter. If the 815 stage

is adequately shielded and has no tendency to self-oscillate, there will be no flicker of the meter pointer as  $C_{15}$  is tuned from one end of the range to the other. If, on the other hand, there is a sharp rise or dip of the pointer at one or more points, shielding is not adequate and it is likely that the parts must be rearranged in the 815 circuit. If there is no change in the meter deflection, proceed with (10).

(10) Throw meter switch  $S_2$  to position 3. Complete the 815 "B+" line by inserting the special short-circuiting socket on the modulation input plug on the chassis. Then tune  $C_{15}$  slowly until the pointer of the meter dips sharply downward. The lowest point of this dip indicates correct tuning of the 815 plate tank to the grid input signal.

### Practical Operation

Future tuning operations are facilitated by the recorded settings of the  $C_{11}$  and  $C_{12}$  dials. The following is an example of rapid tuning procedure.

28-29.7 mc. (1) Insert 10-meter coil  $L_4$ . (2) Set  $S_1$  to crystal between 7000 and 7425 kc. (3) Set  $S_2$  to position 1. (4) Set  $C_1$  to 2nd harmonic. (5) Set  $S_2$  to position 2, and  $C_{12}$  to recorded setting corresponding to 4 times crystal frequency. (6) Set  $C_{11}$  to 4th harmonic of crystal frequency, noting upward swing of meter. (7) Re-set  $C_{11}$  and  $C_{12}$  for highest swing. (8) Throw  $S_2$  to position 3 and adjust  $C_{15}$  for minimum dip of meter.

Note: Another scheme would be to set  $L_1-C_1$  to the crystal fundamental and  $L_2-C_{11}$  and  $L_3-C_{12}$  to the 4th harmonics of the crystal.

50-54 mc. (1) Insert 5-meter coil  $L_4$ . (2) Set  $S_1$  to crystal between 6250 and 6750 kc. (3) Set  $S_2$  to position 1. (4) Set  $C_1$  to 2nd harmonic of crystal frequency. (5) Set  $S_2$  to position 2, and  $C_{12}$  to recorded setting corresponding to 8th harmonic of crystal frequency. (6) Set  $C_{11}$  to 8th harmonic of crystal frequency, noting upward swing of meter. (7) Re-set  $C_{11}$  and  $C_{12}$  for highest swing. (8) Throw  $S_2$  to position 3 and adjust  $C_{15}$  for minimum dip of meter.

### Loading During Tests

It is inadvisable to make tuning adjustments over a long period without a load of some kind connected to the 815 output. For this purpose a dummy antenna of any one of the conventional designs may be concentrically-connected to jack J.

### Modulator Requirements

A satisfactory audio power stage for 100 per-cent modulation of the 28-54 transmitter may be connected through a cord socket to the modulator input plug on the back of the chassis. This audio stage, which should be of the transformer-output type, must have an undistorted r.m.s. power output of 20 watts and an output impedance of 2340 ohms.



# ny s b e o he Naked Eye

but you'll want these\* in your Plastic Parts

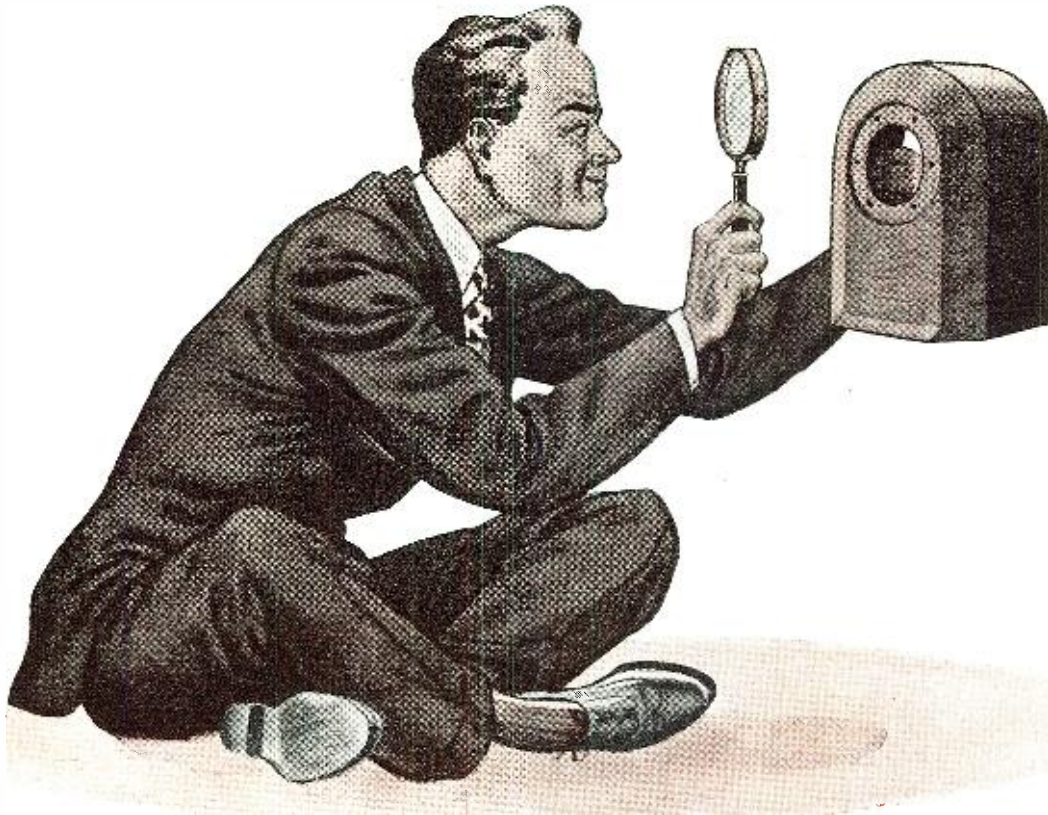

WHETHER you're interested in food machine housings or any other larger parts, the same thing applies—these hidden qualities *add value* to your product:

- 1. Minimized internal stress
- 2. Uniform density
- 3. Most thorough cure possible
- 4. Better finish
- 5. No "weld" lines
- 6. Generally improved properties
- 7. Less or no washing of inserts (fewer rejects)

These are seven of the by-products of incorporating Heatronics (radio fre-

quency pre-heating) into standard molding techniques. And they're qualities you'll probably want in your next molding job.

We've been developing Heatronic molding standards since one of the first units in the industry was delivered to our plant—today we can show you a large and still-growing Heatronic installation, as well as many outstanding molding jobs accomplished through its use. We do the whole job, of course—designing, mold-making, molding and finishing—and we can talk business.

If you're interested in these plus-values in plastics, ask for a Kurz-Kasch engineer.

### "A Businessman's Guide to the Molding of Plastics"

Send for your free copy of this illustrated brochure. Just write to Dept. 7 on your letterhead and we'll send it with our compliments.



THE WAR BONDS YOU KEEP ARE THE BONDS THAT COUNT

# Kurz-Kasch

For over 28 years Planners and Molders in Plastics

Kurz-Kasch, Inc., 1429 South Broadway, Dayton 1, Ohio. Branch Sales Offices: New York • Chicago • Detroit • Indianapolis • Los Angeles • Dallas • St. Louis • Toronto, Canada. Export Offices: 89 Broad Street, New York City



January, 1946

127



# PHONOGR PH RECORDS

FOR TESTING AND DEMONSTRATION WORK

Use them in your engineering dept.—for demonstration work, sales booths, etc. Current popular numbers—slightly used but guaranteed playable.

**1000 for \$150<sup>00</sup>**

SATISFACTION GUARANTEED

**STARK'S** 509 So. State St.  
Chicago 5, Ill.



**WAR SURPLUS BARGAINS**

**BIG SAVINGS**  
Hundreds of specials for RADIO SERVICEMEN

- CATHODE RAY TUBES
- POWER & TRANSMITTING TUBES
- HEADPHONES, etc.
- HARD-TO-FIND TEST METERS

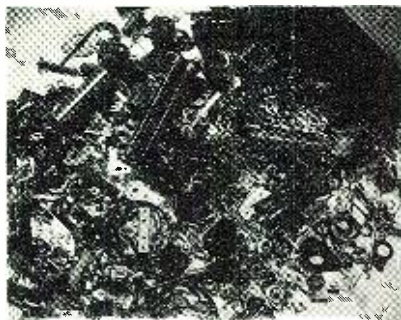

### 7 LB. RADIO PARTS ASSORTMENT

A "gold mine" for the radio serviceman. Hundreds of valuable radio parts, including rivets, sol spring lugs, sockets, coils, resistors, condensers, switches, transformers, etc. An amazing value. Money-back guarantee.

**K130R — FULL 7 POUNDS ONLY \$179**

### War Surplus Bargain Book

Page after page of war surplus and other bargains for the radio serviceman; all 50 specials for home, shop and outdoors.

**IT'S FREE! WRITE TO-DAY**



**STARK'S** Dept. RN146 509 So. STATE STREET  
CHICAGO 5, ILLINOIS

## SPEAKERS RECONED!

4"—\$1.15    6"—\$1.35    10"—\$2.25  
5"—\$1.25    8"—\$1.85    12"—\$2.50

Plus Transportation

Prompt Service—Expert Workmanship

**York Radio**

DISTRIBUTING COMPANY

Quality Parts for the Radio Profession

545 No. Water St. DECATUR 22, ILL.



**Ted McElroy**  
World's Largest Manufacturer of Wireless Telegraphic Apparatus  
COMPLETE CENTRAL OFFICE EQUIPMENT  
**McElroy Manufacturing Corp.**  
82 Brookline Avenue • Boston, Massachusetts

# Manufacturers' Literature

Readers are asked to write directly to the manufacturer for the literature. By mentioning RADIO NEWS, the issue and page, and enclosing the proper amount, when indicated, delay will be prevented.

In view of the present paper shortage, a limited number of copies of the booklets described herein are printed. Manufacturers will endeavor to comply with all requests; however, if your copy is not received after proper request has been made, it most likely will indicate that the supply is exhausted.

### REGULATOR BULLETIN

Bulletin 164, featuring automatic voltage regulators, is offered by the *Superior Electric Company* to cover a wider selection of applications.

All available ranges of the standard regulators are listed, together with a description of recent mechanical and electrical improvements. In addition to illustrations of automatic voltage regulators, a number of typical application photographs are also included.

Copy of Bulletin 164 may be secured from the *Superior Electric Company*, Sales Department, Bristol, Connecticut.

### NEW CANNON BULLETIN

The *Cannon Electric Development Company* announces as ready for distribution its revised edition of the Type "K" Bulletin.

The 64-page book contains valuable information on "K" and "RK" plugs, receptacles, dust caps, junction shells, stowage receptacles for aircraft, instruments, radio, motors, geophysical equipment, and general electrical applications. Of further interest are the many photographs, exploded views, production illustrations, orthographic dimensional sketches, and application pictures, included in addition to the data on the various styles of "K" connectors.

For free copy of the bulletin, application may be made directly to the *Cannon Electric Development Company*, Catalog Department, 3209 Humboldt Street, Los Angeles 31, California.

### PIEZO-ELECTRIC CRYSTAL CATALOG

Announcement of a new Piezo-Electric Crystal Catalog is made by the *Aireon Manufacturing Corporation*.

This booklet features a wide variety of standard and special types, principally the Octal type, with cylindrical metal shield and standard eight-pin base; three-pin, two-channel, aircraft type; standard two-pin phenolic holders for various kinds of mobile and stationary installations (banana or pin plugs); and variable air-gap mounting with screw-top electrode.

Of particular interest is the new compact type designed for commercial transmitters or receivers where space is at a minimum, and where the crystal will be incorporated in circuit like a resistor or condenser. Supplied in a

molded case with wire leads at frequencies of 2-10 megacycles, the unit may also be furnished as an i.f. filter, with soldering lugs, at 455 kc. or any specified frequency.

For copy of the catalog, address request to the *Aireon Manufacturing Corporation*, Advertising Department, Kansas City, Kansas.

### CATHODE-RAY TUBE BULLETIN

In a bulletin entitled "DuMont Cathode-Ray Tubes for Television," the *Allen B. DuMont Laboratories, Inc.*, presents a comprehensive selection of numerous types and sizes of cathode-ray tubes particularly adapted to television reception.

The pamphlet lists and also illustrates several 5-inch, 7-inch, 10-inch, 12-inch, and 20-inch tubes of both the electrostatic and the magnetic deflection categories, together with the more significant characteristics. Announcement is also made of the development of a new 15-inch magnetic deflection tube. In each instance the useful picture area is given.

The *Allen B. DuMont Laboratories, Inc.*, 2 Main Avenue, Passaic, New Jersey, will be glad to furnish copy of the bulletin in question.

### FINE WIRE BOOKLET

"Fine Wire of Special Materials" is the name of an 8-page booklet prepared by Robert L. Zahour of *North American Philips Company, Inc.* It brings to the trade in graphic portrayal the steps in the manufacture of fine wire of nickel alloys, precious metals, etc., for precision electronic and electrical applications. Up-to-date manufacturing methods and problems connected with wire .002" to .0007" in diameter, and smaller, are discussed. The pamphlet covers important steps in producing a good diamond die; drawing the wire; methods for checking diameter, elongation, tensile strength and ohmic resistance; and x-ray diffraction examination of atomic structure, etc.

Ten photographs add to the interest and understanding of the subjects covered.

Copy of the booklet may be had from the Wire Division of the *North American Philips Company, Inc.*, 100 East 42nd Street, New York 17, N. Y.

### ELECTRICAL INSULATING FOLDER

The *Continental-Diamond Fibre Company* offers to design and produce



tion engineers its quick-reference folder of electrical and mechanical properties entitled "Engineered Electrical Insulating Materials."

Brief descriptions and photographs of the products are given, together with comprehensive graphs showing dielectric strength, power factor, dielectric constant, tensile strength, compressive strength, impact strength, specific gravity, and moisture absorption.

Engineers may obtain copy of this reference folder by writing the *Continental-Diamond Fibre Company*, Newark 49, Delaware.

#### POWERSTAT BULLETIN

To cover recent developments of the Powerstat variable transformers, Bulletin 149A has been issued by the *Superior Electric Company*.

The bulletin contains general and specific information pertaining to motor-drives, capacities, and applications. Illustrations included are line drawings of a variety of circuit arrangements in which the Powerstat may be used, graphs showing performance data, outline dimensions of certain models, and application photographs.

Further information regarding Bulletin 149A will be supplied by the *Superior Electric Company*, Sales Department, Bristol, Connecticut.

#### CRYSTAL RESEARCH LAB CATALOG

*Crystal Research Laboratories, Inc.*, which specializes in the mass production of crystals ground to critical tol-

erances, presents in attractive eight-page form a pamphlet covering the development, work, and products of its company, and listing the standard and special types of crystals available.

The different types of crystals manufactured are depicted in both illustrated and descriptive form, and featured on the back cover is a series of photographs in the facsimile of a movie film strip, showing the various consecutive steps taken in production from the raw quartz to the finished crystal. Also included are numerous illustrations of plant facilities.

A free copy of this catalog may be secured by writing the *Crystal Research Laboratories, Inc.*, 29 Allyn Street, Hartford 3, Connecticut.

#### CONTROLS CATALOG

Thermostats and pressure switches for a wide variety of requirements are listed in "Condensed Catalog and Price List, No. 4591-C, issued by the *United Controls Company*.

Among those fully described as well as illustrated are liquid immersion thermostats, room-type thermostats for heating and cooling control, aircraft-type temperature and pressure-vacuum controls, pressure switches for various applications, explosion-proof and dust-tight pressure and vacuum controls, and pressure and vacuum switches. A listing of electrical ratings adds to the value of the 12-page booklet.

The *United Electric Controls Company*, 69-71 A Street, Boston 27, Mas-

sachusetts, will furnish copy of the catalog upon request.

#### BARREL BOOKLET

In a 16-page brochure, the *Federal Machine and Welder Company* makes available information covering steel-container-making equipment.

Profusely illustrated, this attractive booklet shows many styles of steel containers, as well as the equipment used in their manufacture. Detailed description accompanying the photographs builds interest in the step-by-step story of the steel drum. A schematic layout of the *Federal* barrel plant shows the location and various types of equipment employed in the production of the steel containers.

A booklet will be supplied upon writing the *Federal Machine and Welder Company*, 212 Dana Street, Warren, Ohio.

#### ELECTRONIC EQUIPMENT LIST

Available to manufacturers, distributors, and industrial users, the *Electronic Corporation of America* announces its second catalog listing of electronic equipment and components.

The new catalog illustrates many of the more desirable items and lists a greater variety and larger quantity of condensers, resistors, variable condensers, sockets, and other equipment.

Interested individuals, as mentioned above, may obtain further information from the *Electronic Corporation of America*, 45 West 18th Street, New York, N. Y.

-30-

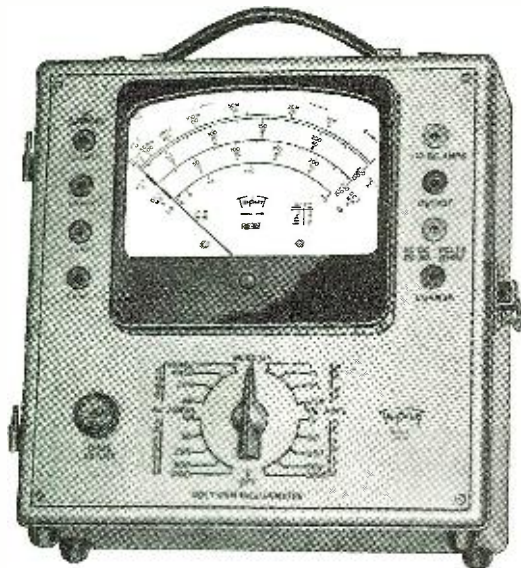

#### NEW ENGINEERING • NEW DESIGN • NEW RANGES 50 RANGES

Voltage: 5 D.C. 0-10-50-250-500-1000 at 25000 ohms per volt.

5 A.C. 0-10-50-250-500-1000 at 1000 ohms per volt.

Current: 4 A.C. 0-.5-1-5-10 amp.

6 D.C. 0-50 microamperes — 0-1-10-50-250 milliamperes—0-10 amperes.

4 Resistance 0-4000-40,000 ohms—4-40 megohms.

6 Decibel -10 to +15, +29, +43, +49, +55

Output Condenser in series with A.C. volt ranges.

*Model 2400 is similar but has D.C. volts Ranges at 5000 ohms per volt.*

Write for complete description

#### MODEL 2405

## Volt•Ohm•Milliammeter

25,000 OHMS PER VOLT D.C.



#### SPECIFICATIONS

NEW "SQUARE LINE" metal case, attractive tan "hammered" baked-on enamel, brown trim.

■ PLUG-IN RECTIFIER—replacement in case of overloading is as simple as changing radio tube.

■ READABILITY—the most readable of all Volt-Ohm-Milliammeter scales—5.6 inches long at top arc.

■ RED•DOT LIFETIME GUARANTEE on 6" instrument protects against defects in workmanship and material.

# Triplet

## ELECTRICAL INSTRUMENT CO.

BLUFFTON OHIO.



## What's New

(Continued from page 72)

This new video amplifier operates on a voltage of 110 to 120 volts, 60 cycles with a power consumption of 100 watts. A compact unit, it weighs 35 pounds complete with tubes and probe and occupies a space of 7¼" by 9" by 20¾".

This amplifier is a product of *United Cinephone Corporation*, Torrington, Connecticut.

### U.H.F. WAVEMETER

*General Radio Company* has announced a new wavemeter for rapid measurements of frequency in the range of 240 to 1200 megacycles. It is the type 1140-A u.h.f. wavemeter, which covers the frequency range in a single direct-reading range with an accuracy of  $\pm 2\%$ .

The tuning element is a butterfly-type tuned circuit which is coupled to a standard cartridge-type crystal detector. Crystal current, as indicated in a microammeter, gives an indication of resonance. Where the available power is not sufficient to actuate the microammeter, the reaction of the wavemeter upon the current in the circuit under measurement can be used.

This new wavemeter has a net weight of 3¼ pounds and measures

3⅞" x 7¼" x 4½" over-all. The entire assembly is housed in a small molded plastic case that can be conveniently held in one hand.

Further information may be obtained from *General Radio Company*, Cambridge 39, Massachusetts.

### COIL VARNISHING MACHINE

A semi-automatic coil varnishing machine was designed at *Clippard Instrument Laboratory*, Cincinnati, to impregnate government order r.f. coils with a uniform coating of varnish requiring close tolerance on over-all diameter.

The machine is driven by a 1/32 h.p. synchronous motor. The motor shaft extends into a sealed gear box, worm driving a shaft at 50 to 1 ratio, coupled to the rear varnish drum in the varnish unit at the right. This shaft, in turn, chain-drives the forward drum shaft at 1 to 1 ratio, making both drums revolve in the same direction. Weight of varnish film is controlled by adjustable scrapers abutting the horizontal surfaces of both varnish drums.

### AMATEUR COMMUNICATIONS RECEIVER

Announcement of a new professional type amateur receiver, designated as HQ-129-X, is made by the *Hammarlund Manufacturing Company, Inc.* This model, the manufacturer advises, is designed to meet all the demands

of the discriminating expert but is still within the price range of the average amateur and short-wave fan. It will replace the company's well-known HQ-120-X, and is described as embodying a number of engineering refinements resulting in improved performance.

The receiver features the full frequency range of .54 to 31 mc., accurately calibrated; band spread with 4 calibrated ham bands and one arbitrary scale; variable selectivity crystal filter for phone as well as code reception; low-drift beat oscillator for code and aid in locating stations; antenna compensator to provide maximum image rejection and high sensitivity; voltage regulation reducing effects of line voltage fluctuation; compensated oscillator to reduce drift during warm-

up; new type automatic noise limiter, reducing many types of interference; headphone jack which cuts out speaker when phones are used; three amplifier stages; two audio stages with improved tone quality; eleven tubes, including voltage regulator and rectifier; and a cabinet streamlined in appearance, finished in attractive two-tone gray, black knobs and escutcheon.

Further information on this product may be obtained from the *Hammarlund Manufacturing Company, Inc.*, 460 West 34th Street, New York 1, N. Y.

### "WATCH DOG" STARTER

*General Electric Company* has now available a new "Watch Dog" starter for 15- and 20-watt fluorescent lamps, especially suitable for commercial and residential lighting fixtures.

Among its outstanding features are



the precision lamp starting and dead lamp lockout. This new G-E device is timed to light the lamp at the right instant, thus conserving emissive material essential to long lamp life and prolonging the life of the starter. The lockout of dead lamps quickly and positively is made possible by close tolerances in the starter's mechanism, which also eliminates blinking and flickering. When a dead lamp is removed, the "Watch Dog" is reset simply by pressing a button on top of the starter. The new lamp is then inserted, and the "Watch Dog" brings it into the circuit immediately.

This new starter has all the features and advantages of other "Watch Dogs" which are available for 30-, 40- and 100-watt fluorescent lamps, and bears the catalog number FS-20.

### TRU-SONIC COAXIAL SPEAKERS

A new speaker, developed to meet the demand for a small, low-cost, two-way sound reproducing assembly that would give performance comparable to that provided in larger, separate two-way sound systems manufactured by them as custom-built installations, has been placed on the market by the *Stephens Manufacturing Company*.

The assembly of the Tru-Sonic coaxial speaker consists of a low-frequency paper cone, a high-frequency diaphragm operating into a multicellular horn, and a dividing network, all mounted on a rugged cast aluminum frame, 15½" in diameter and 9½" in depth. A distinctive feature is the multicellular horn, which allows

# PAPER AND TRANSPARENT TUBES

## SPIRAL WOUND



## for the RADIO and ELECTRICAL FIELD

Exact specification work in large or small quantity lots. Prompt Delivery. Get quotation on Condenser Tubes, Socket Liners, Etc. Etc.

Diameters:  
1/16" to 3"

DIAMOND STRAW & MACHINE CO

114-116 East  
New York



16th Street  
N. Y.



a vertical sound distribution of 40 degrees and a horizontal distribution of 80 degrees.

The speaker will be available either



with or without a modern, specially designed cabinet.

Further details on this product will be supplied by the *Stephens Manufacturing Company*, 10416 National Boulevard, Los Angeles 34, California.

#### RECORDER TUBE

A new cold cathode recorder tube which provides high intensity point-of-light source for radio and wire facsimile receivers and many other recording instrument applications has been announced by the *Industrial Electronics Division of Sylvania Electric Products Inc.*, Boston, Massachusetts.

It is a modulator glow tube of the crater type that is rugged and dependable for facsimile and sound-on-film recording; oscillograph timing markers; stroboscopic devices; seismic recorders; and photoelectric counters. Current through the tube varies linearly with the signal voltage regardless of changes in tube impedance. Used in a typical facsimile receiver the light output of the tube is focused through a baffle with a sharp rectangular opening to produce a spot of light .0072" high and .0104" wide on a drum rotating at 90 r.p.m. Scanning movement is .0104" per revolution.

Type R-1130 recording tube is supplied in a T-9 bulb with intermediate shell octal base and may be operated in any position. Providing a useful light range between 3500 and 6500 angstroms, it will respond to frequencies between 15 and 15,000 c.p.s. Rated



January, 1946

## Meet the Demand for Duotone's Duodiscs and Cutting Needles!



The mushrooming market in home-recording demands that all dealers be prepared to meet the needs of these enthusiasts. Give them the best—Duotone's Duodiscs for greater fidelity, longer wear and noiseless reproduction. Coated with nitrate on a base of aluminum, these Duodiscs will sell and then resell themselves. Follow up with Duotone Cutting Needles and you can't miss. Write now for specific prices and details.

**RELATED PRODUCTS:** *Duotone Hardening Fluid* which preserves the recording; the *Duotone "Star" Sapphire*; *Shadowgraphed Transcription Needles* for quality playbacks.



**DUOTONE COMPANY**  
799 Broadway, New York 3, N. Y.

In Canada: Sni-Dor Ltd., Montreal



# NOW—A REALLY HIGH-POWERED— Radio Engineering Library

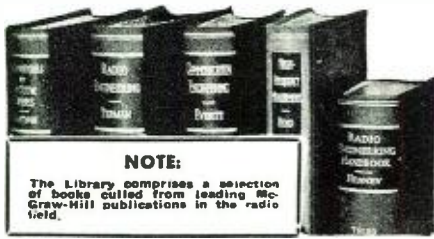

**NOTE:**

The Library comprises a selection of books culled from leading McGraw-Hill publications in the radio field.

- especially selected by radio specialists of McGraw-Hill publications
- to give most complete, dependable coverage of facts needed by all whose fields are grounded on radio fundamentals.
- available at a special price and terms

THESE books cover circuit phenomena, tube theory, networks, measurements, and other subjects—give specialized treatments of all fields of practical design and application. They are books of recognized position in the literature—books you will refer to and be referred to often. If you are a practical designer, researcher or engineer in any field based on radio, you want these books for the help they give in hundreds of problems throughout the whole field of radio engineering.

- 5 VOLUMES, 3550 PAGES, 2550 ILLUSTRATIONS**
1. Eastman's FUNDAMENTALS OF VACUUM TUBES
  2. Terman's RADIO ENGINEERING
  3. Everitt's COMMUNICATION ENGINEERING
  4. Hund's HIGH FREQUENCY MEASUREMENTS
  5. Henney's RADIO ENGINEERING HANDBOOK

10 days' examination. Easy terms. Special price under this offer less than books bought separately. Add these standard works to your library now; pay small monthly installments, while you use the books.

10 DAYS' FREE EXAMINATION—SEND COUPON

McGRAW-HILL BOOK CO.,  
330 W. 42nd Street, New York 18, N. Y.

Send me Radio Engineering Library, 5 vols. for 10 days' examination on approval. In 10 days I will send \$3.00 plus few cents postage, and \$3.00 monthly till \$24.00 is paid, or return books postpaid. (We pay postage on orders accompanied by remittance of first installment.)

Name .....

Address .....

City and State .....

Company .....

Position .....

**FREE** 150 Shop Print Book

● It's my outright "get acquainted" gift—a bound book of 150 ELECTRICAL SHOP PRINTS & DIAGRAMS of fullsize 8½" x 11". It's yours FREE.

**FOR MERELY EXAMINING THIS NEW BOOK ON  
Electronics Servicing**

Now you can easily understand the principles, operation and servicing of electronic equipment—the newest phase of electricity and radio. 400 pages. Simplified explanations of electronic tubes for welding and other industrial application, phototubes, gas and vapor filled tubes, etc. A practical book for OLD-TIMERS or BEGINNERS in electricity or radio. Praised by educators, union officials, superintendents, etc.

**SEND NO MONEY** Here's my offer—send coupon below. I'll send you my new Electronics book for 7 days examination and my book of 150 Shop Prints which is an outright gift to you. If you like the Electronics book send \$4.95 after 7 Days; if not return the book and you owe nothing. In either case, however, the book of 150 Shop Prints is yours to keep free. Offer limited—rush coupon.

**FREE GIFT BOOK COUPON**

H. C. Lewis, Pres., Coyne Electrical School, Dept. 16-T3, 500 S. PAULINA STREET, CHICAGO 12, ILLINOIS

Send me ELECTRONICS for ELECTRICIANS or RADIO MEN. Also send me bound volume of 150 Shop Prints which I am to keep FREE whether I keep the ELECTRONICS book or not. I'll either return the Electronics book in 7 days and owe you nothing or send you \$4.95. I'll keep the book I am also to get one year of technical bulletins free.

NAME .....

ADDRESS .....

TOWN .....

Zone .....

STATE .....

at 135 volts d.c. with currents ranging from 5 to 35 ma., it requires a starting voltage of 170 volts d.c. maximum.

**ANTENNA AMMETER**

A new electronic remote antenna ammeter which operates on a new principle without the usual thermocouples has been developed by the Andrew Company.

The remotely located d.c. microammeter is actuated by a current transformer feeding a diode-rectifier tube located at the antenna. Since the regular thermocouple ammeters can be disconnected most of the time, the station using this new unit is spared the frequent cost of meter replacement. Station shutdowns due to thermocouple failure in lightning storms may be

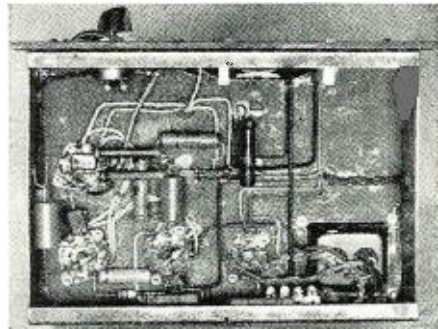

Underchassis view of completed instrument.

eliminated with the use of this new device.

For additional details, write for Bulletin 28A, Andrew Company, 363 E. 75th Street, Chicago 19, Illinois.

—30—

**Signal Tracer**

(Continued from page 51)

variety of possible troubles—a defective tube, no plate voltage, shorted screen condenser, open cathode circuit, etc. (It is not the scope of this article to present all the troubles that one would encounter in troubleshooting, but merely to show how defective stages are easily isolated).

The next step in signal-tracing procedure is to test at the diode plates, where again signals should be heard. (Always rock the receiver condenser gang at each point of test to compensate for loading of tuned circuits with the probe). The signal path continues to the high side of the diode load resistor (volume control), where only audio should be present. Apply the probe to the high end of the volume control. You will be pleasantly surprised to hear a clear signal, as in previous stages, without having made any changes with the tracer. The signal tracer automatically biases itself for either r.f. or a.f.!

Proceed with the probe to the grid of the first audio (6Q7 tube). The signal strength should be about the same as the previous test. Now apply the probe to the first audio (6Q7) plate. The volume should be consid-

erably greater. Any defect will show up readily. Weak signals might be due to a poor tube. Improper bias will cause distorted reception. Lack of signal can be due to an open plate load resistor, etc. Next, put the probe on the grid of the power tube (6F6). Continue to the plate of the power tube. The gain will be so great that the signal will be picked up as you approach the plate circuit. In fact, merely waving the probe around a glass-type power tube will be sufficient to pick up the signal. A distorted signal can be caused by a leaky coupling condenser, shorted cathode condenser, open grid resistor, etc. The final test point will be the speaker voice coil. If the signal tracer responds to signals, but the receiver shows no response, it would indicate an open voice coil.

On all audio signals, the magic eye will flutter with sound intensities, thus making it adaptable as a volume indicator. Additional tests can be made with the signal tracer; hum can easily be traced to its originating source by placing the probe on the B+ leads. The percentage of ripple is amplified by the tracer. Fading circuits are isolated by noting the circuits where signals remain constant and where the fading originates.

The signal tracer can be used as an audio amplifier by making use of the microphone input jack on the right of the panel. Microphones and phono pickups can be tested.

It is easily seen that this signal tracer is a very useful instrument, and yet it is very simple, the only control being a volume control. Almost every radio bug has enough spare parts on hand to build this tracer which will certainly repay itself many

Fig. 3. Mechanical layout of panel.

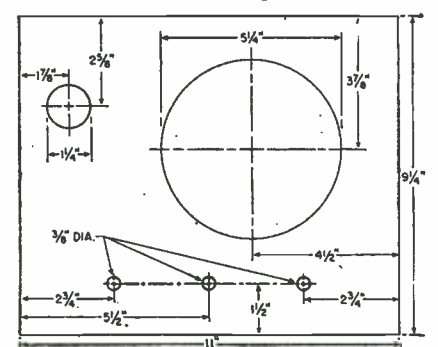



times over. It will be a valuable addition to the test bench along with the other testing devices. It should be a boon to the beginner who needs a test instrument that he can easily operate.

—30—

## Resistance Measurements

(Continued from page 46)

vin bridge, sometimes called a double bridge, for measuring resistances below 1 ohm.

### Wheatstone Bridge

A wheatstone bridge (Fig. 5) is a closed resistance network of four arms. Two of the arms (*A* and *B*) are ratio arms and are usually fixed resistances. The *C* arm is a variable arm, usually fixed resistances controlled by a switch and made so up to 1000 ohms in .1 ohm increments. The *X* arm is the unknown resistance. A source of voltage is, in most cases, applied between the *B* and *C* arms and the *A* and *X* arms. A galvanometer, having high voltage sensitivity, is connected between the junctions of the *A* and *B* arms and the *C* and *X* arms. Balance of the bridge (no galvanometer reading) is had when:

$$X = \frac{A}{B} C$$

The accuracy of commercial laboratory wheatstone bridges runs from .5 of 1% in portable models to .02% in high precision models.

A variation of the wheatstone bridge employs a slide wire in place of fixed ratio arms and a fixed resistance standard in place of the *C* arm. Although the accuracy of the slide-wire bridge is usually less than that of the fixed-ratio bridge, it has the advantage of greater speed in reading.

### Kelvin Bridge

The wheatstone bridge cannot be successfully used to measure low resistances. If we take a bar of metal and try to measure its resistance by means of a wheatstone bridge, several important facts must be borne in mind. The resistance of the connecting leads must be accurately known, since they contribute to the resistance indicated by the bridge. Resistance of the contacts between the bar and the connecting wires must be known for the same reason. By employing large low-resistance cable as connectors, the former can be deducted from the bridge reading, but the latter (contact resistance) can never be accurately known. Because of this fact, the wheatstone bridge is never used to measure below .1 ohm, although theoretically it is possible.

In the Kelvin bridge, the resistance of the connecting leads and contacts are unimportant since they are put in series with the comparatively high-resistance ratio arms. This can be done only by employing current and potential terminals for both the standard

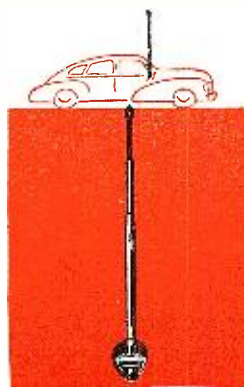

#### ICA "ROCKER"

A new swivel aerial, adjustable to any angle; fits contours of all car bodies.

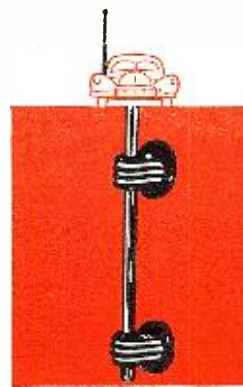

#### ICA "SIDE COWL"

Noiseless, rattleproof and rust proof; in five different lengths; two-three- and four-section telescopic.

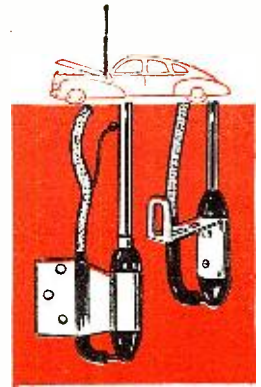

#### ICA "UNI-MOUNT"

Eliminates drilling of holes into body of car; one aerial for all type mountings.

# Immediate Delivery! AUTO RADIO ANTENNAS

The new Insuline antennas are rolling off the production line. Quality—as always—is the prime factor in the new ICA design. Check the eight important features below and see why Insuline has so long led the field.

1. Improved design—modern streamline beauty.
2. Beautiful triple-chromium plated—will enhance appearance of all cars.
3. All Antennas employ newly designed, sturdy bakelite insulators.
4. Brass inserts with attachments assure permanent corrosion-proof contact and wear.
5. Patented brass shim contacts used on all telescopic joints to prevent "rattling" and vibration. Contacts are permanent.
6. Static discharge tear-drop bead supplied on all aerials.
7. Brass tubing scientifically tapered on ends to prevent moisture and dust from entering tubes.
8. All antennae supplied with fool-proof spring tensioned Lo-Loss cables protected by heavy shielded loom to prevent noise pickup.

An assortment of sizes and types to meet the needs in different locations and conditions. Used as standard equipment by car manufacturers, U. S. Government agencies, police departments, secret service department, rangers, and on farm tractors, etc. The current ICA catalog, detailing the full line of ICA antennas is yours for the asking.

Remember: All ICA Antennas are rattle-proof and rust proof.

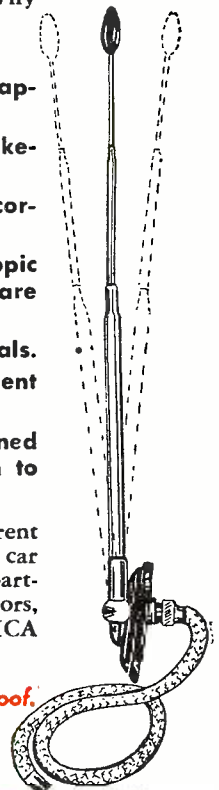

**insuline**  
Insuline Corporation of America



INSULINE BUILDING • LONG ISLAND CITY, N. Y.



**IMMEDIATE DELIVERY!**  
**SIGNAL CORPS**  
**TELEGRAPH KEY**

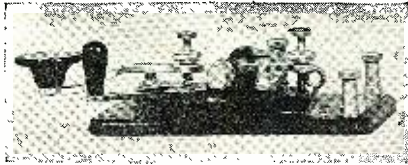

Genuine U. S. Signal Corps key with switch to close contacts, polished durable enameled metal base mounted on a bakelite base, key lever is nickel-plated brass-silver contacts; packed in new, original boxes. Shipping weight, 1 lb. . . . **\$1.29 ea.**  
 10 for \$11.00

**Army-Navy Type HEADPHONES**

Type HS-33

Save up to 70% on genuine U.S. Signal Corps headphones. These are the better \$10.00 headphones for only \$2.95. Leather-covered headband, detachable rubber cushions, lightweight construction, impedance 8000 ohms. Ea. **\$2.95**



Order from your jobber or write direct. Write for our illustrated literature featuring all types of radio parts.

**ARROW RADIO CO.**

2205 W. Division St., Dept. C, Chicago 22, Illinois

and the unknown resistance. The resistance measured by the Kelvin bridge is the resistance between the potential leads only. Fig. 6 illustrates the operation of the Kelvin bridge.

*A and B* : The regular ratio arms similar to those employed in a wheatstone bridge.

*a and b* : A duplicate set of ratio arms.

*Yoke* : This is the connecting bar between the standard and the unknown. Note that *a* and *b* shunt the yoke and therefore its resistance does not enter into the calculation.

*C and C'* : The current connections of the standard resistance.

*C'' and C'''* : The current connections of the unknown.

*P and P'* : The potential leads of the standard.

*P'' and P'''* : The potential leads of the unknown.

*G* : The galvanometer that is used to indicate when the bridge is balanced.

Since all the heavy current goes through the current terminals (there is only a low circulating current flowing through the ratio arms) the contact resistance of the potential leads has no effect on the measured resistance. A commercial laboratory version of a high precision Kelvin bridge is that manufactured by the Leeds & Northrup Company and comprises two units, the 4320 dual ratio box and the 4300 low resistance standard.

The dual ratio is made up of 10 re-

sistors, two each of 100-300-400-1000 and 10,000 ohms. These coils are adjusted to better than .05% of their nominal value. They are controlled by plugs and give ratios of 100, 10, 1, .1, and .01 of the standard. Other ratios can be had by inserting the plugs into other combinations of jacks. Since the lowest ratio arm resistance is 100 ohms, contact and lead resistance can be as high as .01 before an error of .01% is had from this source. In practice, contact and lead resistance is much less than .01 ohm.

In this case, the standard resistance consists of nine coils, each .001 ohm, plus a calibrated bar .0011. These resistances are accurate to .02%. The nine coils in conjunction with the calibrated bar have the effect of a bar 10 times as long. Nine coils can carry a current of 50 amperes continuously and the bar alone can carry 150 amperes. The bar is calibrated to 100 divisions, and a vernier screw allows readings down to .1 division. Range of this Kelvin bridge is from .000,000,011 to 1 ohm, with an accuracy of .04%.

A portable Kelvin bridge is diagrammed in Fig. 7. This is the Leeds & Northrup type 4286 Kelvin bridge ohmmeter. The portable bridge compares the unknown resistance against 5 standard resistances by means of a dual ratio arm that is variable. Resistance of the unknown is equal to the dial setting of the ratio arms multiplied by the standard in use, with the dial calibrated .01 to .11 ohms. The

The nation's first radio-equipped bus is now in operation experimentally on lines of the Washington, Virginia, and Maryland Coach Company. Installation followed receipt by the coach company of the first permit issued by the Federal Communications Commission for operation of this type of service. The radio is being used to test its effectiveness in improving bus service and to operate in public emergencies. It will be used as a two-way communications medium between the bus operator and the company's headquarters in Arlington, Va., and parallels service of this kind in operation since July between headquarters and the company's service and supervisors' cars. General Electric engineers explain that the FM equipment is of a type developed for wartime emergency communications and now being used by other utility companies and police departments. The radio is installed in one of the regularly scheduled buses of the company. It will not be confined to any one route. Before tests are completed, the bus will have operated on 87 miles of routes of the company, covering about 30,000 miles in the experiment, according to Joseph L. Arnold, vice-president and general manager.

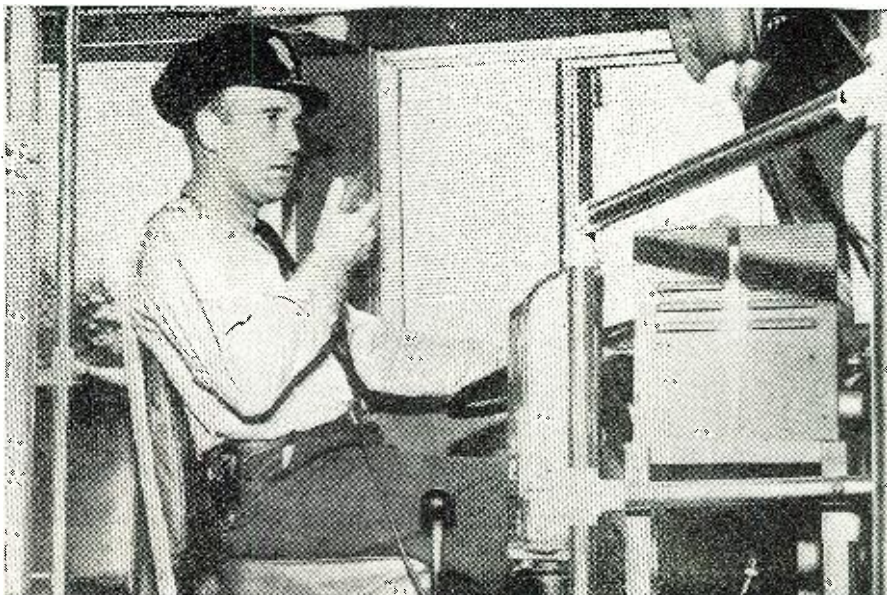

**FREE TO YOU**

**COLOR CODE and OHMS LAW CALCULATOR**

**Great Time Saver**

Burstein-Applebee of Kansas City offers you this great convenience FREE. Easy to work. Solves many problems in a jiffy. FREE to Radio men, electronic engineers and others in the business. Attach coupon to your letterhead.

**MAIL COUPON NOW**



BURSTEIN-APPLEBEE CO.  
 1012 MCGEE ST.  
 KANSAS CITY 6, MO.

Send me FREE Color Code and Ohms Law Calculator along with latest catalog.

I am \_\_\_\_\_  
 STATE CONNECTION IN INDUSTRY

NAME \_\_\_\_\_

ADDRESS \_\_\_\_\_

TOWN \_\_\_\_\_

STATE \_\_\_\_\_



range of the portable bridge is from .0001 ohm to 11 ohms, and the error is less than 2% of the setting.

### Special Circuits

Besides the above mentioned methods, special circuits are sometimes used:

The No. 1 Weston ohmmeter uses a D'Arsonval movement, but with a tapped coil. The current through one coil remains constant, while the current through the second section varies with the resistance connected across the meter terminals. Its coils are so wound that when no resistance is in the circuit, the torque of the two coils are equal and the meter reads zero. When a resistance is inserted in the circuit, the current in the "resistance" coil only partially nullifies the current of the "current" coil, causing the meter to read up scale. Provisions are made for adjusting the meter by means of a magnetic shunt to compensate for aging of the battery. A mirror scale is provided and the scale is very close to linear.

The *megger* is an instrument, formerly made in England but since the war manufactured in the United States, that is used primarily to measure insulation resistance. The instrument consists of a dual (current and voltage) coil, shaped like a T, rotating in the field of a permanent magnet. No springs are used in the instrument. The magnet also supplies

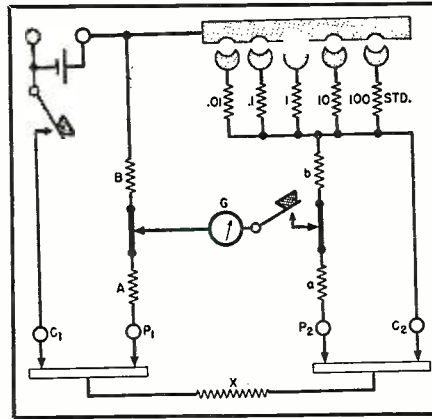

Fig. 7. Diagram of Leeds & Northrup portable type 4286 Kelvin bridge ohmmeter.

the field for a small d.c. generator with a potential of 500 volts, which is operated by rotating a hand crank. In operation the crank is rotated and the 500 volts generated is applied to the voltage coil, turning the coil so that the pointer appears at the "infinity" mark on the scale. 500 volts is also applied to the resistance (insulation) through the current coil. The torque produced by the current passing through the current coil and the insulation resistance, opposes the torque of the voltage coil, causing the pointer to swing away from the infinity mark to a point on the scale corresponding to the resistance being measured. A

"megger" finds its chief use in measuring insulation resistance where a source of power cannot be had. The range of this instrument is usually 100 megohms and 500 volts. Special instruments can be had to measure resistance up to 20,000 megohms at a test potential of 2500 volts.

A special resistance meter recently designed by the writer is worth describing. It operates on the bridge principle, but in place of a null indicating meter, the meter is calibrated from 1 to 10. The range of the instrument is from .1 ohm to 10 megohms in decade steps—i.e., .1 ohm to 1 ohm, 1 to 10 ohms, 10 ohms to 100 ohms, etc. With a meter scale of 90 divisions, each division represents 1% of full scale. The meter can be read with ease to 1/4 division or 25% of full scale. The meter has been built in several ways. It has been used as a limit bridge, a temperature bridge, and a resistance meter. As a limit bridge it has been made as sensitive as  $\pm .1\%$  of the standard in use. As a resistance meter it has replaced a regular bridge, since it is speedier in operation; resistances are measured as quickly as in a conventional ohmmeter, but with the accuracy of a bridge.

Methods other than outlined above have been occasionally used in resistance measurements. However, they are not as common and are seldom used.

-30-



MANUFACTURERS • START TO FINISH

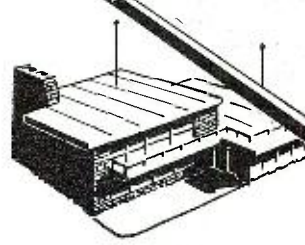
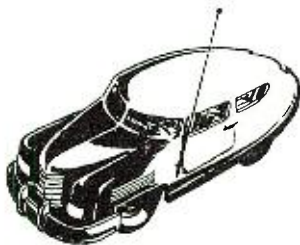

AUTOMOBILES

BOATS

HOMES

HANDY-TALKIE



## CLEAN ACCURATE HOLS



### cut in radio chassis

Greenlee Punches make this tough job easy. No reaming, filing or tedious drilling. Tool has three parts: punch cuts through chassis, die supports metal to prevent distortion, cap screw is turned with wrench to cut holes. Sizes for holes 3/4" to 3 1/2". Ask your radio supply or electrical jobber or write for folder and prices. Greenlee Tool Co., 1893 Columbia Ave., Rockford, Illinois.

WRITE FOR FREE FOLDER S-119



# Within the INDUSTRY

**LYNN A. SAYLOR** has been appointed advertising and sales promotion manager of the *Warwick Manufacturing Corporation* of Chicago, according to an announcement by John S. Holmes, president.



Mr. Saylor was formerly advertising and sales promotion manager of the *Certain-teed Products Corporation* and has been associated for thirteen years with the *Hotpoint* organization, subsidiary of *General Electric*. Mr. Saylor is a member of the Advertising Manager's Club of Chicago, the Illinois Committee of the Chicago Association of Commerce, and the Speaker's Bureau of the Community and War Fund of Chicago.

\* \* \*

**JAMES F. WELDON**, export manager of *Sperti, Inc.*, has been appointed a member of the Radio Manufacturers Association Export Committee by President Cosgrove. This is the eleventh year in which this honor has been bestowed on Mr. Weldon.

\* \* \*

**EDGAR S. RIEDEL**, for thirteen years general sales manager of the receiving Tube Division of *Raytheon Manufacturing Company*, Newton, Massachusetts, has announced his resignation from the company.



Mr. Riedel has been engaged in radio merchandising since the first days of broadcasting and was one of the nine original organizers of the Radio Manufacturer's Association in 1923. During the period that *National Carbon* had an option to buy *Raytheon*, Mr. Riedel resigned and joined *Utah Radio Products Company* of Chicago as vice president and general sales manager. In 1933, *National Carbon Company* canceled their contract with *Raytheon* and Mr. Riedel rejoined *Raytheon* as their general sales manager. Mr. Riedel will announce his future business plans shortly.

\* \* \*

**NEWARK ELECTRIC COMPANY**, Chicago and New York radio parts jobber, has enlarged its quarters at 323 West Madison Street, Chicago, by adding some 7,000 square feet of floor space. *Newark* has taken over and is remodeling the entire basement, which will be devoted exclusively to its mail order business. Some 2,000 square feet of space in the rear of the store will be

divided into a number of booths to permit demonstrations of receivers, transmitters, and sound and test equipment.

The Chicago store is managed by Abe Poncher. Along with its expansion program, *Newark* has enlarged its sales and distribution staff to include: Joe Sheffer, John Burke, Merlin Star, G. W. Mossbarger, Michael Schmitz, George Eskridge, William Ousley, Jr., and Eddie Childs. The New York City store, recently enlarged, is directed by Adolph Gross.

\* \* \*

**D. J. SWEENEY** has been appointed engineer in charge of mechanical development of the research and advance development department of the engineering division of the *Crosley Corporation*.



Mr. Sweeney has been associated for the past ten years with the *General Electric Company* of Bridgeport, Conn. Prior to that time, he was associated with the *Radio Corporation of America* in Camden, N. J., and with the *Western Electric Company*, in Springfield, Mass.

\* \* \*

**MARVIN HOBBS**, formerly consulting engineer for the *E. H. Scott Radio Laboratories* and the War Production Board, has returned to resume duties with *Scott* after a tour of duty as operations analyst with the Far East air forces.

Mr. Hobbs left this country in June 1945 and travelled to the Philippines and Okinawa, where he was engaged in research work on the field use of radio, radar, and teletype equipment employed in aircraft control and warning operations. He arrived in Yokohama early in September and was among the first to visit Japanese laboratories, factories and schools engaged in radio and radar development, production, and training.

\* \* \*

**D. R. DOOLEY**, formerly assistant sales manager of *Automatic Electric Sales Corporation*, has been appointed vice president in charge of sales of *C. P. Clare & Company*. Mr. Dooley has long specialized in the application of relays and switches to electronic and other industrial uses.

\* \* \*

**BALDWIN LOCOMOTIVE WORKS**, South-west Division, has placed field sales engineers who are specialists in the use and applications of the SR-4 strain gauge in five of the company's branch offices. Richard Hannon will be in the Boston office; Joseph Farley, Chicago;

For Radio  
as you want it!

We're still up to our ears  
in critical war work but  
when the war's won we  
will again be ready

..To DESIGN, DEVELOP  
and MANUFACTURE..

Radio Receivers and Transmitters  
Industrial Electronic Equipment  
Airport Radio Control Equipment  
Marine Radio Telephone Equipment

Your inquiries will receive immediate action

ISLIP RADIO MFG.  
CORPORATION

ISLIP, L. I., NEW YORK



Robert Cleeland, New York; Glenn Rowell, Philadelphia; and Stanley Zansitis, Detroit. Jordan H. Gaul is SR-4 sales manager at the Eddystone, Pa., office.

\* \* \*

**MAGUIRE INDUSTRIES, INC.**, has coordinated the sales activities of several subsidiaries with the formation of a new distribution and industrial sales department.



Robert M. Karet, formerly sales manager of the wholesale and sound divisions of

Utah Radio Products Company, has been named manager of the newly created department. All distributor and industrial sales of Maguire subsidiaries serving the electronic field will be coordinated under Mr. Karet's direction. Maguire subsidiaries include Meissner Manufacturing Division, Thordarson Electric Manufacturing Division, and Radiart Division.

Maguire Industries recently purchased the Radiart Corporation of Cleveland, manufacturers of radio parts and accessories.

\* \* \*

**MUELLER ELECTRIC COMPANY** of Cleveland is now under way with the first step in its postwar plant expansion program. Construction has been started on a completely new plating and finishing plant, which will be outfitted with the most modern and efficient types of plating and bulk handling equipment. This expansion program is expected to add about one-third, to Mueller's present manufacturing space.

\* \* \*

**L. ROBERT EVANS** is the newly appointed regional manager for Brazil, according to an announcement by Philco International Corporation.



Mr. Evans was active in South American markets over a period of 16 years as a member of the RCA Victor

sales and manufacturing staff in Brazil and Chile. He was formerly manager of the International Division of Utah Radio Products Company of Chicago.

Mr. Evans will establish his headquarters in Rio de Janeiro.

\* \* \*

**NORMAN S. KORNETZ** has been appointed project engineer in charge of Westinghouse television receiver development, according to an announcement by Harold B. Donley, manager of the Home Radio Division, Sunbury, Pa.

Mr. Kornetz recently returned to this country after serving with the U. S. Signal Service Corps in India, where, as a captain with the 3105th Signal Service Battalion, he was in charge of all administrative radio

January, 1946

# Service Approved EICOR DYNAMOTORS

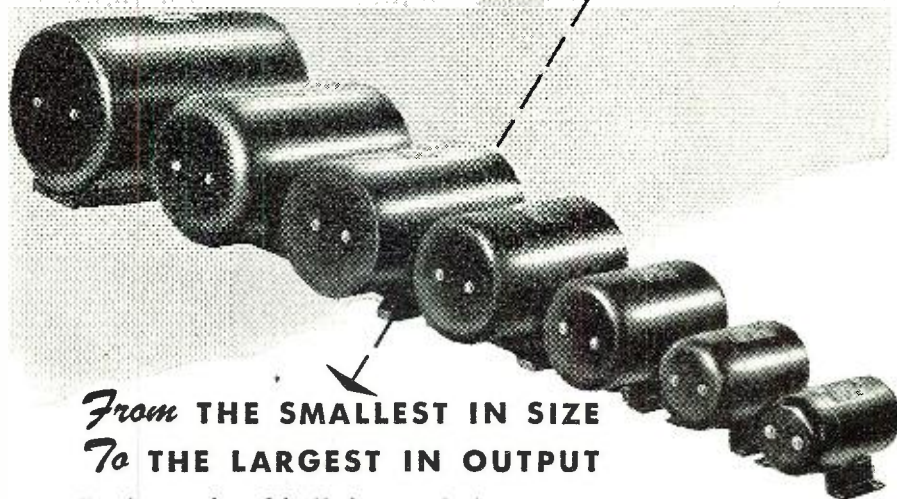

From THE SMALLEST IN SIZE To THE LARGEST IN OUTPUT

Engineered and built by specialists, EICOR DYNAMOTORS have earned their fine reputation through years of exacting service. These dependable units furnish the necessary high voltage power for communications, direction finding, radio compass and other controls.

Our complete line of frame sizes makes possible the widest available range of dynamotor output ratings in the most compact sizes and weights. This assures the most economical size and weight for every need!

The experience and skill of Eicor Engineers are instantly available to help you on any problem involving Dynamotors, Motors, or Inverters.



Send for Helpful DATA FOLDER

This handy folder gives useful data and information on EICOR Dynamotors, D. C. Motors, and other Rotary Electrical Equipment. Write for it!

SERIES NO.	MAX. OUTPUT WATTS	DIAMETER	LENGTH	WEIGHT
2300	10	2 <sup>5</sup> / <sub>8</sub> in.	4 <sup>7</sup> / <sub>8</sub> in.	2 <sup>1</sup> / <sub>8</sub> lbs.
2700	15	2 <sup>3</sup> / <sub>4</sub> in.	4 <sup>3</sup> / <sub>4</sub> in.	2 <sup>3</sup> / <sub>4</sub> lbs.
3400	125	3 <sup>7</sup> / <sub>8</sub> in.	5 <sup>5</sup> / <sub>8</sub> to 8 <sup>1</sup> / <sub>2</sub> in.	4 <sup>1</sup> / <sub>2</sub> to 7 <sup>1</sup> / <sub>2</sub> lbs.
4100	200	4 <sup>1</sup> / <sub>8</sub> in.	6 <sup>1</sup> / <sub>2</sub> to 7 <sup>3</sup> / <sub>8</sub> in.	6 <sup>3</sup> / <sub>4</sub> to 9 lbs.
4500	250	4 <sup>1</sup> / <sub>2</sub> in.	6 <sup>1</sup> / <sub>2</sub> to 8 in.	11 <sup>1</sup> / <sub>2</sub> to 13 <sup>1</sup> / <sub>4</sub> lbs.
5100	350	5 <sup>1</sup> / <sub>8</sub> in.	8 <sup>1</sup> / <sub>2</sub> to 10 in.	17 to 21 <sup>1</sup> / <sub>2</sub> lbs.
6100	500	6 <sup>3</sup> / <sub>8</sub> in.	9 <sup>5</sup> / <sub>8</sub> to 12 in.	28 to 36 lbs.

**EICOR, INC.** 1501 W. Congress St., Chicago, U. S. A.

DYNAMOTORS • D. C. MOTORS • POWER PLANTS • CONVERTERS

Export: Ad Auriema, 89 Broad St., New York, U. S. A. Cable: Auriema, New York



## 110-VOLTS AC from DIRECT CURRENT

with KATO KONVERTERS. Furnish standard 110-volt AC from 32, 110, or 220-volts DC. Good deliveries on sizes 350 through 1500 watts.

PIONEERS IN THE BUILDING  
OF SMALL ROTARY CONVERTERS

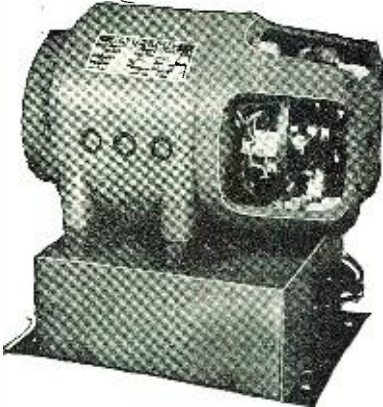

Katolight Rotary Konverter 225 Watt

Good deliveries on 5, 7½, 15 and 25 KW AC generators. Mfg.'s DC generators, motor generators, frequency changers, high frequency generators.

Special motors and generators 25 to 800 cycles.

KATO ENGINEERING CO.  
120 Rock Street Mankato, Minnesota

# 7 Days Free Examination

## PRACTICAL RADIO INFORMATION

Including Frequency Modulation—Television, etc.

Inside Radio Information for all Servicemen—Aircraft Pilots, Students. AUDELS RADIO-MANS GUIDE contains 772 Pages, 400 Diagrams & Photos is complete—gives Authentic Principles & Practices in Construction, Operation, Service & Repairs. Covers clearly and concisely Radio fundamentals—Ohm's Law—Physics of sound as related to radio science—Measuring instruments—Power supply—Resistors—Inductors—Condensers—Transformers and examples—Broadcasting stations—Radio Telephony—Receivers—Diagrams—Construction—Control systems—Loud speakers—Antenna systems—Auto Radio—Phonograph pickups—Public Address Systems—Aircraft & Marine Radio—Radio Compass—Beacons—Automatic Radio Alarms—Short Wave—Coil Calculations—Testing—Cathode ray oscillographs—Static Elimination—Trouble Pointers—Underwriter's standards—Units and tables—Frequency Modulation—REVIEW QUESTIONS & ANSWERS. Ready Reference Index.

**\$4 COMPLETE • PAY ONLY \$1 A MO.**  
Get this practical information in handy form for yourself—Fill in and MAIL COUPON TODAY—

AUDEL Publishers, 49 W. 23rd St., N.Y. Mail AUDELS NEW RADIOMANS GUIDE for free examination. If O. K., I will send you \$1 in 7 days; then remit \$1 monthly until \$4 is paid. Otherwise I will return it.

Name \_\_\_\_\_  
Address \_\_\_\_\_  
Occupation \_\_\_\_\_  
Reference \_\_\_\_\_ R.N.

communications in the Calcutta area. Before joining the Signal Corps in 1942, Mr. Kornetz worked on television receiver development for *American Television Corporation* of New York City and later as a specialist in design and development of broadcast and aeronautical receivers and phonograph recorders for the *Colonial Radio Corporation*.

Mr. Kornetz will have charge of all *Westinghouse* home television receiver development and will devote his particular attention to receiving units to be used in flight tests of Stratovision.

\* \* \*

**WILLIAM F. HOSFORD**, vice president and director of *Western Electric Company* since 1928, recently completed 45 years of service with the company.

Devoting most of his long service to scientific manufacturing methods, much of the telephone equipment used by *Bell System* and huge quantities of communications equipment supplied by *Western Electric* during the war to the armed forces were manufactured under the supervision of Mr. Hosford.

William Hosford is also director and former president of *Nassau Smelting and Refining Company*, director and member of executive committee of *Teletype Corporation*, director of *Bell Telephone Laboratories*, *Western Electric Export Corporation*, *Weco Corporation*, *Manufacturers' Junction Railway Company*, *Northern Electric Company* and *Western Electric Company, Ltd. of Canada*.

\* \* \*

**INTERNATIONAL TELEPHONE AND TELEGRAPH CORPORATION** has elected John W. Humphrey vice president in charge of manufacturing. Mr. Humphrey was associated with the *National Cash Register Company* since 1940 in charge of manufacturing, and prior to that time served for twelve years with *General Motors Corporation*.

\* \* \*

**TECHNICAL APPLIANCE CORPORATION** has consolidated its wartime New York and Flushing plants at the latter location. The Flushing plant had been devoted to extensive wood-working activities, while the New York plant produced radar antenna rigs and various electronic products. The company's offices will also be located in Flushing.

\* \* \*

**ELECTRONIC CORPORATION OF AMERICA** has acquired an additional plant at 5302 Second Avenue, Brooklyn, for the manufacture of *ECA* radios and other products. The company will continue to operate its two Manhattan factories.

\* \* \*

**THE HALLCRAFTERS COMPANY** has purchased the plant of *Shelby Shops, Inc.*, Shelbyville, Ind., and established

*Shelby Woodcrafters, Inc.*, as a wholly owned *Hallcrafters* subsidiary to produce part of the cabinet requirements of the company's *Echophone Division*.

Russ Owens, for the past five years chief engineer of *Philco Corporation's* cabinet division in Philadelphia, will supervise the Shelbyville operations.

\* \* \*

**AIREON MANUFACTURING CORPORATION** is now offering to railroad operators and related groups a one-reel, natural color, sound film, title "Railroading by Radio." The film is made in dimensional animation and live action, depicting the two-way combined induction and space radio telephone equipment which *Aireon* builds for installation on trains. The history of railroad signaling and communications, from the earliest form of arm signaling to present day electric equipment, forms the background for this showing of the newest in railroad communications.

Several prints of this film are now available for showing, and requests for copies should be addressed to Clay Crane, director of advertising and public relations, *Aireon Manufacturing Corporation*, Kansas City 15, Kansas.

\* \* \*

**BELMONT RADIO CORPORATION**, subsidiary of *Raytheon Manufacturing Company*, has announced the election of the following executive officers: Laurence K. Marshall, president; Harold C. Mattes, executive vice president; Charles M. Hofman, vice president; Carl J. Hollatz, vice president; William L. Dunn, vice president; John Robertson, treasurer and assistant Secretary; Donald L. Trouant, secretary.

\* \* \*

**SOUTHERN WHOLESALEERS, INC.**, recently appointed distributor for the *Crosley Corporation* in Jackson, Miss., has announced the election of S. D. Campner as president.

Mr. Campner has been in the major household - appliance business for the past 19 years. For the past 8 years he has been associated with *Crosley* and recently resigned as southeastern regional sales manager. Associated with Mr. Campner as vice president of *Southern Wholesalers Inc.*, is B. H. Brown, who has been connected with the firm of *Orgil Brothers*, formerly *Crosley* distributor in Jackson.

\* \* \*

**RMA** membership has been increased by twenty-two more companies, bringing the membership to a new high of 273 member companies. The new RMA members are: *American Trans-former Company*, *De Mornay-Budd, Inc.*, *Eastern Electronics Corp.*, *Franklin Photographic Industries*, *Hartford Industries, Inc.*, *Hazeltine Electronics Corp.*, *Industrial Electronic Corp.*, *Lewis Electronics*, *Modern Electronic*



Co., Inc., National Design Service, National Moldite Co., Noma Electric Corp., Peerless Electrical Products Co., Radio Receptor Co., Inc., Ray-energy Radio & Television Corp., Regal Electronics Corp., Stamford Electric Products, Inc., Symphonic Radio & Electronic Corp., United States Trunk Co., Inc., Waters Conley Co., Wilmak Corp., and The Workshop Associates.

**EMERSON RADIO AND PHONOGRAPH CORPORATION**

has appointed Commander Herbert C. Guterman executive assistant to Benjamin Abrams, president.



During the war Commander Guterman served as head of the Electronic Components Group

of the Production Division of the Bureau of Aeronautics. In addition he served on several combined Army-Navy Allied Nations committees dealing with precedence, procurement, and allocation of electronic equipment.

Mr. Guterman will assist Mr. Abrams with executive and administrative matters.

\* \* \*

**YORK RADIO DISTRIBUTING COMPANY,** distributors for Operadio Manufacturers, David Bogen, Inc., Stancor Transformers, Tung Sol Tubes, Hickok and Simpson test equipment, and other leading parts manufacturers, has moved from Elmhurst to 545 North Water Street, Decatur 21, Illinois.

\* \* \*

**PRODUCTS OF TOMORROW EXPOSITION** is scheduled to open April 27 for a 22-day run at the Chicago Coliseum. Planning and general management is under the direction of Marcus W. Hinson, manager, National Chemical Exposition. Leo A. Seltzer, vice president and general manager, Coliseum Corporation, is heading business and entertainment management. Complete information regarding space costs, contracts, and other facts may be had by writing on company letterhead to Chicago Coliseum, 1513 S. Wabash Avenue, Chicago 5, Illinois.

\* \* \*

**GALVIN MANUFACTURING CORPORATION**

has transferred Murray Yeomans from the eastern territory to its new headquarters in St. Louis. He will serve in the capacity of midwest regional manager.



Mr. Yeomans entered the radio field in 1931 in the service and engineering departments of Motorola. During the war he served as an expeditor in the New York-Philadelphia area. In his new position Mr. Yeomans will have charge of a group of midwestern and southern

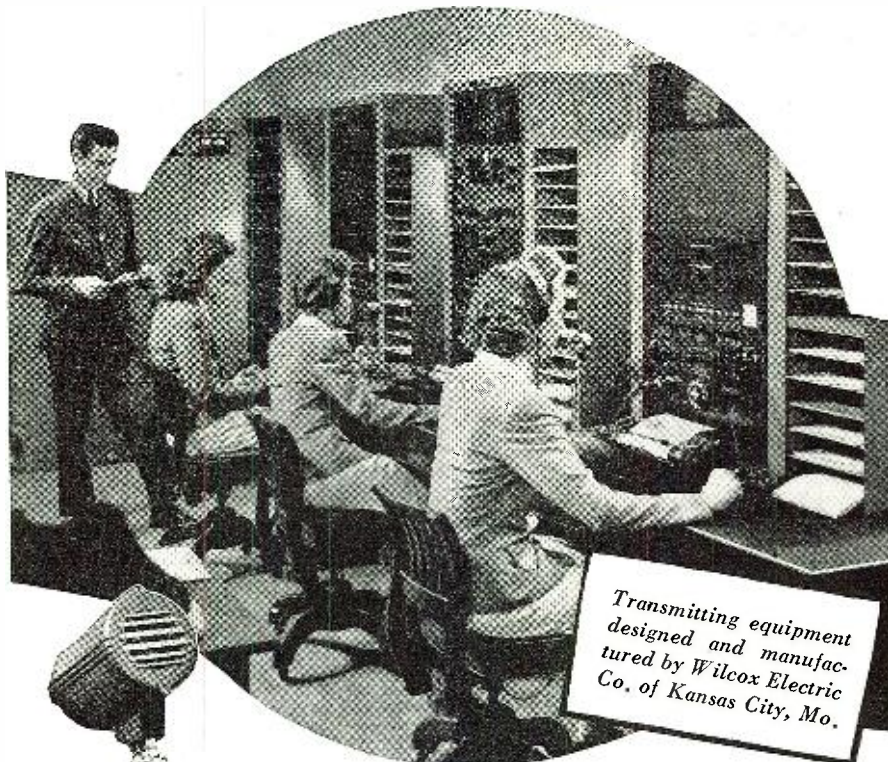

## Important INSTALLATIONS

Include Astatic Microphones for Long, Dependable Service

● Astatic Crystal and Dynamic Microphones, long recognized for dependable, efficient service, have many uses and applications. That's why you find them included in

many important installations such as the airline control and dispatching office, illustrated above, public address and inter-office communicating systems, police call stations, recording sets, and other types of modern communication systems. Astatic Microphones and Phonograph Pickups are known and used around the world.

ASTATIC Crystal Devices manufactured under Brush Development Co. patents.

**THE Astatic CORPORATION**  
 CONNEAUT, OHIO  
 IN CANADA: CANADIAN ASTATIC LTD., TORONTO, ONTARIO



**SERVICE MEN'S HEADQUARTERS  
FOR QUICK DELIVERY! . . .**

**THIS MONTH'S SPECIAL**

**VOLT-OHM MILLIAMMETER**



- Model 697  
Illustrated  
\$24.00 net
- 
- Weston Analyzer  
Model 772 type 6  
\$49.50 net
- 
- Weston Tube  
Checker Model 777  
\$49.50 net

**ORDER TODAY WHILE THEY LAST**

We carry a complete line of standard:

- TESTING EQUIPMENT
- AMPLIFIERS
- RECORDING DEVICES
- PHONO PICKUPS
- MICROPHONES

and ALL Hard-to-Get EQUIPMENT for which you have been waiting. Many standard Sound Systems available for Immediate Delivery at \$100 and up, complete with tubes

Sound Advice and Sound Estimates Cheerfully Given • SEND US YOUR PROBLEM

*Jack Greene*

79 CORTLANDT, NEW YORK 6, N. Y.

**MONEY-SAVING  
SPECIALS**

Immediate Delivery. Orders filled same day received



**AIRPLANE  
CODE KEY  
\$2.25**

Knee type. Strong spring holds securely. Black enamel and brass finish. Complete with plug and cord. Limited supply. Order now. Only—\$2.25.

**DESK TYPE KEY—\$1.69**

Cadmium plated. A good practice for amateurs.



**PL-55 PLUG—34c**

A high grade, dependable plug.

**G. E. AMMETER**

General Electric Thermocouple R. F. type—only \$4.95.

**NEW ITEMS DAILY**

Tubes test equipment meters cables and condensers resistors switches speakers. Write for bulletin listing hundreds of items.



**Lifetime  
SOUND EQUIP. CO., Dept. 42  
911-913 JEFFERSON AVE., TOLEDO 2, OHIO**

states, including Missouri, Kansas, Tennessee, Indiana, and Kentucky.

**N. A. MOERMAN** has been appointed sales engineer of the *Potter Instrument Company*, Flushing, N. Y., designers and manufacturers of high-speed electronic counting control equipment.



For the past six and one-half years Mr. Moerman was employed at the Aberdeen Proving Grounds, Maryland, where he was responsible for the design and maintenance of various electronic measuring apparatus.

**UNITED STATES TELEVISION MANUFACTURING CORPORATION** has announced the unanimous re-election of Hamilton Hoge, Captain USMCR, now on terminal leave, as president. John Hoge, who acted as president during the war, remains as vice president and treasurer, as well as president of *Huber Hoge & Sons*, advertising agency.

**RADIO RECEPTOR COMPANY, INC.**, New York, has appointed F. G. Harlow Washington and government representative. Mr. Harlow was associated for many years with *Westinghouse Electric Company* of Washington, D. C., as sales engineer.

**HARRY E. HARRIS**, previously sales engineer for *Bell Sound Systems, Inc.*, has been named general sales manager of the manufacturers and jobbers sales division.

*Bell Sound Systems* manufacture sound equipment of all types, electronic phonographs, amplifiers for electrical guitar equipment and other specialized electronic devices.

**H. B. MACARTNEY**, vice-president in charge of sales for *Hammarlund Manufacturing Co. Inc.*, was presented with the Hammarlund "Twenty-Year Gold Watch" by Lloyd A. Hammarlund, president. Mr. Macartney has served as purchasing agent, general manager, vice-president and general manager, and finally, vice-president in charge of all sales. The gold watch



is awarded to all employees on their twentieth anniversary with the company.

**FM in Canada**  
(Continued from page 31)

with the nature of present CBC proposals, he declared he saw no reason why private broadcasting service to the public should be reduced at gain of the CBC outlets.

Private broadcasters generally do not object to the government's hand in radio and frankly admit that without government participation most of Canada's rural population would be left without radio service. Nor do they object to the government-imposed \$2.50 license fee on receivers or the licensing fees collected from broadcasters on a sliding-scale basis. Under the sliding-scale arrangement, a 5000-watt in Vancouver, for example, each year pays to CBC around \$4000 for its year-long permit to broadcast.

Any attempt by the CBC to tie up private operators in FM, however, will simply delay its development, according to the general opinion among private licensees. As Mr. Bannerman points out, private licensees of several of Canada's regional stations "simply cannot parallel their present coverage job in FM." And they will be reluctant to provide less, rather than more, coverage in FM.

Meanwhile, the Canadian government has given the green light to all types of radio construction and is eager to move swiftly in acting on the sixty some applications for FM stations now before it.

In any event, Canadians may use a January meeting in Washington with U.S. and Latin American representatives on extension of the North American Regional Broadcasting Agreement as springboard for an FM offensive. The NARBA, which apportioned channels in the western hemisphere, expires in March 1946, although both Canada and the U.S. are willing to extend it for another year. That treaty, which now applies only to standard broadcast operations, may be enlarged to embrace FM allocations along this country's northern and southern boundaries.

U.S. engineers agree that constantly rising demand for FM frequencies in Cleveland, Toledo, Detroit, Rochester, and Buffalo may mean a tight squeeze for Canadian stations just over the line, since Canada's most congested areas adjoin these centers. However, they point out, the problem is not insuperable. Canada could, for example, use the twenty channels now spotted for use of U.S. educational FM stations in this area, or could locate its high-powered metropolitan stations on the U.S. low-powered so-called "community station" FM frequencies.

In any event, the consensus is that Canada must move and move soon, and FM will clearly highlight the direction which CBC has planned for Canadian radio in the postwar years. The Canadian system, now plainly "neither fish nor red herring," is tar-



get of attack from all three Canadian political parties, whose counterproposals run the gamut from an outright BBC monopoly to a variation of the "American system."

-30-

**QTC**

(Continued from page 56)

**M.** J. CESTONE, an ol' timer from the Gulf ports, is shipping from the West Coast and is now doing a stretch on the *Nancy Lykes* . . . Don Mealy, ex-marine opr, is with Consolidated Airlines, flying an LB 30 between 'Frisco and Honolulu . . . Les Grogan is back from Alaska fishing and on the *Richard Harding Davis*, a Liberty, but he is looking for a passenger wagon and the "good ol' days."

John Lutterman, ex-Texas Co. opr on the *SS Sea Blaney* . . . Lieut. M. A. Stiltner, former fighter pilot off the *USS Enterprise*, wants his friends to know he is in the merchant marine after he "got it" and if he can't keep 'em flying he will help to keep 'em sailing to bring the boys back home; he's on the *Dennison Victory* out of 'Frisco.

**M.** F. JOHNSON making his "first trip" aboard a Liberty from the West Coast . . . F. Jones is riding his "first" also—as chief on the *T. A.*

*Johnston* . . . T. A. Temple was in port for a few days and was assigned to the *Peter Donhue* . . . Pete Johnson is now a former radio officer—he is doing a stretch as mate, but did not report the name of his ship . . . Norman William reports he is on his "second" trip aboard the *SS John B. Floyd* . . . Geo. Meak is now chief on the *James A. Butts*. George was riding the *President Coolidge* when she hit a mine field; good luck on this one, George! . . . Harry A. Morgan, who resigned as vice president of ACA's marine division some months ago, is now with ACA's local No. 3 at 'Frisco and feeling OK once again. Harry resigned as vp due to ill health. . . . 73

**Listening to the World**

(Continued from page 66)

was only one way to intercept these messages—by obtaining a Hellschreiber. The BBC got one, and then more machines. Thus, they were able to monitor fully both Goebbels instructions and news. At first this was kept secret since it was not known whether the Goebbels organization knew or suspected that Britain was eavesdropping systematically on all his private conversations; or whether, though he knew it, he could do nothing about it since his own Hellschreiber setup was too valuable and elaborate to be scrapped.



The Morse Listening Room, where ordinary telegraph service signals in Morse code are intercepted and copied on the typewriters. High-speed signals are recorded and slowed down later for transcription.

All voice broadcasts are not only heard by the individual monitors (the listeners) but simultaneously recorded on equipment very similar to that of a dictaphone, to insure that what the monitor hears can be checked. The moment a monitor has finished his listening and has made such notes as he requires for his own guidance, he goes into the Information Bureau to confess. This means that he reports every item monitored to a supervisor who knows where this information should be flashed first. This supervisor indicates the appropriate treatment of what the monitor has heard.

The military leader who said that the BBC Monitoring Service had the value for the Allied Forces of 40 divisions was not exaggerating.

-30-

# FIX ANY RADIO

## Amazing New Invention



Find radio faults with a new simplified method. Repair all radios in minutes instead of hours. Revolutionary, different Comparison technique permits you to do expert work almost immediately. Most repairs can be made without test equipment. Simple point-to-point, cross-reference, circuit suggestions locate faults quickly and easily.



### CHARTS, BLUEPRINTS, TESTS, HINTS, JOB-SHEETS

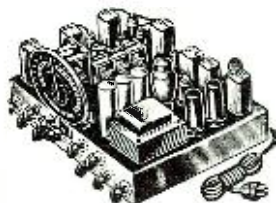

Learn time-saving trouble-shooting short-cuts; find any radio fault with ease. Follow the tests shown on 24 large circuit blueprints. Over 1,000 practical repair hints. Hundreds of simplified tests using a 5¢ resistor and any filter condenser. Introductory material for beginners and to serve as review for experienced radio men. Several chapters on test equipment. Complete plan in manual form; 64 job-sheets; data on all tubes; size: 8 1/2 x 11 inches. Sold on no-risk trial. Money-back guarantee. Use coupon to order.

### NO TESTERS NEEDED REPAIR ANY RADIO IN MINUTES

This newly developed method tells you how to locate the source of trouble in any radio set without equipment. Make needed tests, measure voltage, trace the signal, by using only a 5¢ resistor, small condenser, and a crystal detector. Inject signals without any signal generator. Test parts by the new Comparison method. Test tubes without equipment. Repair any radio expertly following simplified picture plans. Improve your radio servicing ability. Data on all sets, portables, AC-DC, FM, recorders, intercoms, P.A. Examine and apply the plan for 10 days without obligation or risk. Send trial coupon today →

### NO RISK TRIAL ORDER COUPON SUPREME PUBLICATIONS 9 S. Kedzie Ave., Chicago 12, Illinois

Ship postpaid the new complete Simplified Radio Servicing by Comparison Method manual for 10 days' examination. I am enclosing \$1.50, full price. I must be entirely satisfied or you will refund my total remittance.

NAME: ..... RNJ  
ADDRESS: .....



**FREE BOOK**  
SHOWS  
**SHORT CUT**  
TO  
**CODE SPEED**

**ENDORSED BY CHAMPIONS**

Skill, speed, accuracy free of nervous tension brings big pay.

**The One and Only Candler System**

Nothing else like it. It is the course that has made code champions. Will help any sincere man gain greater speed, accuracy and skill. Learn the Candler way.

**Fast, Efficient Operators Needed**

If you need additional speed to be classed as an expert, try the Candler method. It is endorsed by champions. It has produced phenomenal results with a minimum of effort. Why not learn the faster and easier way. Get your copy of the Book of Facts for Code students, Telegraph and Radio Operators.

**CANDLER SYSTEM CO.**

P. O. Box 928, Dept. 2-A, Denver (1), Colo.



**Champion Endorses CANDLER SYSTEM**

T. R. McElroy, Official Champion Radiotelegraph operator of the world with a speed of 75.2 W.P.M., claims his success is due to the Candler System.

**CAPACITORS - OIL, PAPER and ELECTROLYTIC**



**Illinois CONDENSER COMPANY**  
1160 N. HOWE ST. • CHICAGO 10, ILL.

**RADIO NEWS 1945**

INDEX TO VOLUMES 33-34

**AMATEUR**

(See also—Transmitters)

An Inexpensive Remote Antenna Meter (Summer) ..... 43 May  
A Simple Coaxial Switch (Burgess) 58 Nov.  
Build This Victory Transmitter (Dexter) ..... 30 Aug.  
Build Your Own V.h.f. FM-AM Receiver (Rattray) ..... 29 Dec.  
Comparison of Visual and Oral Reception (Pollack) ..... 32 Aug.  
Designing a Commercial Type Front Panel (Goldberg, W2HKW)..... 44 May  
FM for Home Use (Frank, W9JU)... 44 Dec.  
450 mc. Microwave Transmitter (Frank, W9JU) ..... 38 May  
450 mc. Super-Regenerative Receiver (Frank, W9JU).....29 July  
Generating R. F. at 600 mc. (Maron) ..... 51 Sept.  
Hamfesters' Picnic ..... 35 Oct.  
Ham Radio—Today and Tomorrow (Washburn, ex-2AUS, & Williams, W8ODX) ..... 38 Dec.  
Home Constructed 112 mc. Receivers (Gavin, W9YES, & Heytow, W9FAL) ..... 29 Nov.  
"Junk Box" Short Wave Receivers (Hooten, W8KPX) ..... 36 Sept.  
Multi-Band 30 Watt Transmitter (Silver) ..... 48 Feb.  
100 mc. Transmitter (Maron)..... 42 Aug.  
112 mc. Crystal-Controlled Transmitter (Morey, W9KBO)..... 35 Oct.  
112 mc. Converter (Frank, W9JU)... 46 Nov.  
"QRM" a Threat to Amateur Radio (Mobus, W9UAO) ..... 28 Aug.  
Radio Operators' License Regulations (Gregg) ..... 96 July  
Television for the Amateur (Read, W9ETI) ..... 35 Aug.  
Temperature Control in the Design of Stable Oscillators (Tyler)..... 76 Oct.  
The Oscilloscope Applied to Transmitter Checking (Eddy & Howard) 32 Oct.  
The Road to Hamdon (Mobus, W9UAO) ..... 54 Oct.  
Wave Guides (Mallory)..... 36 Dec.  
0-300 Volt Regulated Power Supply (Davis) ..... 38 Sept.

**ANTENNAS**

Antennas for Television Receivers (Noil) ..... 40 May  
It's a Bantamweight (Cohen)..... 64 Apr.

**AVIATION**

Communications Airborne (Flynn).. 32 Mar.  
Communications on the World's Greatest Airline (Haines)..... 25 Apr.  
Electrical Computing Airborne Gunsight (Lasche) ..... 32 Feb.  
Electronic Flight Recorder (Thompson & North)..... 25 Feb.  
Instrument Landing System (Hennessy) ..... 25 Aug.  
Television for Future Airway Traffic Control (Morse) ..... 38 Jan.  
U. H. F. For Federal Airways (Taylor) ..... 32 Sept.

**BOOK REVIEWS**

An Introduction to Electronics (Hudson) ..... 72 Apr.  
Applied Mathematics for Radio and Communication Engineers (Smith) 62 Nov.  
Applied Practical Electricity (The Staff, Coyne Electrical School)....143 Aug.  
Behind the Microphone (Floherly).. 62 Feb.  
Dictionary of Engineering and Machine Shop Terms (Sandy).... 72 Apr.  
Instrument Flying and Radio Navigation (Redfield) ..... 62 Jan.

Introduction to Microwaves (Ramo). 62 June  
Introduction to Practical Radio (Tucker) ..... 84 July  
Meet the Electron (Grimes)..... 62 Jan.  
Prodigal Genius, The Life of Nikola Tesla (O'Neill) ..... 62 Feb.  
Radio Advertising for Retailers (Sandage) ..... 72 Apr.  
Radio Production Directing (Crews). 72 Apr.  
Science Today and Tomorrow (Kaempfert) ..... 60 Sept.  
Simplified Radio Servicing by Comparison Method (Beitman)..... 84 July  
Soul of Amber (Still).....105 May  
Television Programming and Production (Hubbell) ..... 60 Sept.  
The Electrolytic Capacitor (Georgiev) ..... 62 Nov.  
The Radio Amateurs' Handbook (The ARRL Staff) ..... 62 June  
U.H.F. Radio Simplified (Kiver)....143 Aug.  
Wartime Radio Service (Middleton).105 May

**BROADCASTING**

Proposed Frequency Allocations, 25,000 Kc. to 30,000,000 Kc..... 31 Mar.

**COMMUNICATIONS**

China Looks Ahead in Radio (Holloway) ..... 62 Sept.  
11,500 Mile Radio Net..... 50 Aug.  
Foreign Broadcast Intelligence Service (Read, W9ETI) ..... 25 Jan.  
Inter-American Radio (Ogilvie).... 25 May  
Marine Communications (Becker)... 25 July  
Modernizing International Telegraphic Communication (Harrison) 76 Sept.  
Radio-Spearheads Patton Armor (Read) ..... 48 June  
Ultrasonic Communications (Rowe). 48 Oct.

**CRYSTALS**

Quartz Crystal Frequency Measurement (Laing) ..... 46 May  
Quartz Crystal—Today and Tomorrow (Clark) ..... 45 Sept.  
Testing Crystals (Jelstrup) ..... 44 July

**ELECTRONICS**

British Electronic Target Locators (Porter) ..... 28 May  
Electronic Aids to Photography (Turner) ..... 32 May  
Electronics—At Work (Bradford).... 54 June  
Electronic Circuits Perform Mathematical Processes (Beitman)..... 72 May  
Electronic Moisture Indicator (Seidlinger) ..... 35 May  
Electronic Timers (Proctor)..... 53 Oct.  
Installation and Maintenance of Navy Electronic Equipment.... 80 Mar.

**EQUIPMENT (TEST)**

Amplifier-Type Vibrating-Reed Frequency Meter (Turner)..... 46 Sept.  
An Improved Wheatstone Bridge (Silver) ..... 30 Sept.  
Audio Oscillators and Their Applications (Hoadley) ..... 29 Sept.  
Direct Reading Impedance Meter (Dexter) ..... 38 Apr.  
Electronic Volt-Ohmmeter (Arnold).. 48 Nov.  
Electrolytic Capacitor Checker (Turner) ..... 38 Oct.  
5" Oscilloscope Design (Turner).... 36 Aug.  
Impedance Bridge for L.C.R. Measurements (Turner) ..... 42 June  
Linear Sweep Generators (Tatz).... 52 May  
Microfarad Meters—Their Advantages and Limitations (Turner)... 46 Dec.  
Modulated Signal Generator (Welles) 36 Jan.  
New Type Signal Tracer (Litt, 2LCC) 31 Oct.  
Servicemen's Multimeter (Hunter).. 40 Mar.  
Sine-Square Wave Oscillator (Silver) 48 Mar.



The Audio Chanalyst (Liebscher)... 32 Dec.  
 Vacuum Tube Analyzer (Sands)... 38 Nov.

**FACSIMILE**

Facsimile Transmitter and Receiver 43 Mar.

**FREQUENCY MODULATION**

Build Your Own V.h.f. FM-AM Receiver (Ratray) ..... 29 Dec.  
 Easily Built FM Broad Band I.F. Transformers (Lyke) ..... 46 July  
 Facts on FM Station Ownership (Hoefler) ..... 36 June  
 FM for Ham Use (Frank, W9JU)... 44 Dec.  
 FM Radio Relay (Lee)..... 54 Dec.  
 New FM Frequency Converters... 35 June  
 118 mc. FM Proves Successful (McNulty) ..... 52 Apr.

**GENERAL OR MISCELLANEOUS**

Easily Built FM Broad Band I.F. Transformers (Lyke) ..... 46 July  
 "Electronically Yours, G. I. Joe" (Taylor) ..... 36 Feb.  
 French Underground Network During German Occupation (Porter)..... 72 Feb.  
 News From Overseas (Porter) 82 Jan., 58 Mar., 66 May, 72 June, 80 July  
 Plotting Engineering Data (Middleton) 56 Aug.  
 Radio Industry Goes to Press (Carroll) ..... 44 Mar.  
 Talking Doorbell (Meissner)..... 53 June  
 Temperature Control in the Design of Stable Oscillators (Tyler)..... 76 Oct.  
 The Piano of the Future (Kempner) 25 Mar.  
 Tuning For Multivibrator (Talley)... 136 Oct.

**INSTRUCTION (COURSES)**

Practical Radio Course (Ghirardi)  
 Part 30—Spurious Superheterodyne Interference ..... 44 Jan.  
 Part 31—Spurious Superheterodyne Interference ..... 52 Feb.  
 Part 32—Superheterodyne Oscillators ..... 64 Mar.  
 Part 33—Superheterodyne Oscillators ..... 50 Apr.  
 Part 34—Oscillator Circuits..... 50 May  
 Part 35—"Tracking" Superheterodynes ..... 46 June  
 Part 36—"Tracking" Superheterodynes ..... 48 Aug.  
 Part 37—"Tracking" Superheterodynes ..... 48 Sept.  
 Part 38—"Tracking" Superheterodynes ..... 50 Oct.  
 Part 39—Pushbutton Tuning ..... 56 Dec.  
 Television Radio Course (Noll)  
 Part 1—An Introduction to Television ..... 50 Jan.  
 Part 2—The Television Channel. 46 Feb.  
 Part 3—Television Transmitting Equipment ..... 46 Mar.  
 Part 4—The Television Receiver. 32 Apr.  
 Part 5—Antennas for Television Receivers ..... 40 May  
 Part 6—Television R.F. & I.F. Systems ..... 50 June  
 Part 7—Television I.F. System... 52 July  
 Part 8—Television Sound Channel 52 Aug.  
 Part 9—Video Amplifiers ..... 57 Oct.  
 Part 10—Functions of Video Circuits ..... 48 Dec.  
 Theory and Application of U.H.F. (Kiver)  
 Part 9—Coupling Methods ..... 58 Feb.  
 Part 10—Electric Fields ..... 57 Apr.  
 Part 11—Magnetic Fields ..... 57 June

**MEDICAL EQUIPMENT**

Developments of Cardiac Diagnostic Instruments (Rappaport) ..... 25 Sept.

**MILITARY**

Air Corps Radio Praseology Training (Susan) ..... 70 Jan.  
 Bombers' Ears ..... 41 Feb.  
 Captured 1000 Watt Jap Transmitter 96 Oct.  
 Classroom Chores 10,000 Feet Up (Kent) ..... 56 May  
 Dad's Advice to G. I. Joe (Paige)... 28 Apr.  
 "Electronically Yours, G. I. Joe"

**VERSATILE is the name for this RUGGED TURNER mike**

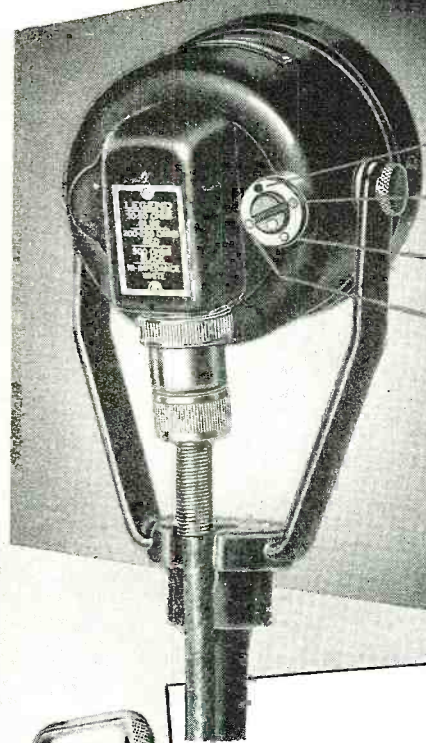

30-50 OHMS

200-250 OHMS

500 OHMS

HIGH IMPEDANCE

**Turner U9S**

**4 Impedance Requirements at Your Fingertips**

A twist of the "selecto-switch" on the Turner U9S gives you a choice of 30-50, 200-250, 500 ohms or high-impedance to fill practically ANY impedance requirement. Removable cable feature permits quick cable changes and its adjustable saddle fits standard microphone stands and allows semi- or non-directional operation. Professional in both appearance and performance, the U9S is a precision instrument, ruggedly built to stand up and deliver under severe service conditions. It is widely used for commercial broadcast, P.A., and police communications work. Level -52DB at high-impedance with response free from peaks or holes from 40 to 9000 cycles. Gunmetal type finish. Complete with 20 ft. removable cable set. Ask your distributor or write.

Complete Turner Catalog describes fully all TURNER Microphones for general and specific applications. Write for your free copy.

**THE TURNER COMPANY**  
 900 17TH ST. N.E.; CEDAR RAPIDS, IOWA



211



Hand-D



33

TURNER

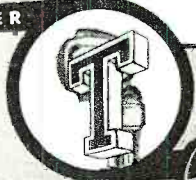

**TURNER**

Pioneers in the communications field

Microphones

Crystals Licensed Under Patents of the Brush Development Co.



*Inside Facts About*  
**ROWE No. 7**  
**PERMANENT MAGNET**

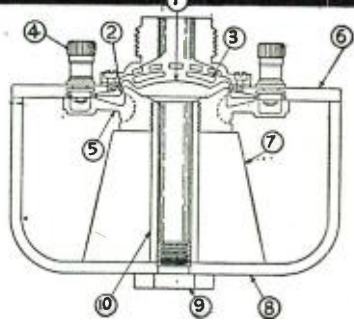

- 1—One-piece metal diaphragm. Voice coil wound on diaphragm.
- 2—Horn mounting accurately centered.
- 3—Perforated die-cast palate.
- 4—Cadmium plated heavy-duty binding posts.
- 5—Flange molded to inner pole piece.
- 6—Outer pole piece of special alloy.
- 7—Heavy ALNICO permanent magnet.
- 8—Bowl of heavy gauge steel.
- 9—Brass assembly nut binds all parts.
- 10—Inner pole piece made of brass.

Write for circular RN-146 giving complete details.

**ELECTRONICS DIVISION**

**ROWE Industries**  
 3120 MONROE ST., TOLEDO 6, OHIO

*For Soldering in  
 Tight Places...*  
**DRAKE**  
 No. 400 Soldering Iron

*Smallest Industrial Iron  
 Ever Designed*  
 60 Watts—1/4 in. Tip  
 Only 9 in. long—Wt. only 8 oz.

This mighty mite is backed by DRAKE'S 25 years of soldering iron manufacturing experience. The high quality and long service of DRAKE Soldering Irons have made them outstanding favorites with all types of radio men everywhere. The DRAKE No. 400 is an outstanding value at



**Only \$4.50**  
List

*Drake Has an Iron  
 for Every Purpose.  
 Ask Your Radio  
 Parts Jobber.*



**DRAKE ELECTRIC WORKS, INC.**  
 3656 LINCOLN AVE., CHICAGO 13, ILL.

(Taylor) ..... 36 Feb.  
 G. I. Plans for Postwar Shop  
 (Hetrick) ..... 46 Apr.  
 News from Overseas (Porter)  
 82 Jan., 58 Mar., 66 May, 72, June 80 July  
 Profession—Flight Radio Officer  
 (Lewis) ..... 80 Apr.  
 Radar Plots the Invasion (Mason).. 64 Oct.  
 Radar—Silent Weapon of World  
 War II ..... 25 Oct.  
 The Proximity Fuse ..... 51 Dec.  
 Wacs at Work (Swasey)..... 35 Feb.

**PHONO**

Tone Control Circuits (Hoadley).... 46 Aug.  
 Tone Control Circuits for Phonographs (Winter) ..... 42 Feb.  
 Unique Volume Expander &  
 Compressor (Stevens) ..... 50 July

**POWER SUPPLIES**

Line Cord Voltage Bank (Davidson).100 Aug.  
 Power Supply Filter Design (Renne) 38 Feb.  
 0-300 Volt Regulated Power Supply  
 (Davis) ..... 38 Sept.

**RADAR**

Practical Radar (McQuay)  
 Part 1 ..... 29 June  
 Part 2 ..... 38 July  
 Part 3 ..... 39 Aug.  
 Part 4 ..... 40 Sept.  
 Part 5 ..... 44 Oct.  
 Part 6 ..... 41 Nov.  
 Radar ..... 35 Nov.  
 Radar Plots the Invasion (Mason).. 64 Oct.  
 Radar—The Silent Weapon of  
 World War II ..... 25 Oct.

**RAILROADS**

Pasadena Police Adopt Handie-Talkie ..... 130 Mar.  
 Radio Cuts 3 Hours Off Freight  
 Train Time ..... 76 July  
 Radio for Transit Utilities (David)... 44 Feb.  
 Two-Way Radio for Highway  
 Freighters (Chaddick) ..... 45 July

**RECEIVERS**

Build Your Own V.h.f. FM-AM  
 Receiver (Rattray) ..... 29 Dec.  
 Emergency Radio Receiver Tests  
 (Distelhorst) ..... 36 Apr.  
 450 mc. Super-Regenerative  
 Receiver (Frank, W9JU)..... 29 July  
 Home Constructed 112 mc. Receiver  
 (Gavin, W9YES, & Heytow,  
 W9FAL) ..... 29 Nov.  
 "Junk Box" Short Wave Receiver  
 (Hooten, W8KPX) ..... 36 Sept.  
 112 mc. Converter (Frank, W9JU)... 46 Nov.  
 Radio for Morale (Read)..... 30 May  
 Simple High-Fidelity Tuner  
 (Kunde, Jr.) ..... 42 July

**RECORDING**

A New Portable Disc Recorder  
 (Peters) ..... 35 Apr.  
 Business Recording Equipment  
 (Stone) ..... 32 Nov.  
 Dual Speed Recording Unit..... 49 May  
 Magnetic Tape Recording (Winter).. 32 June

**RELAYS**

D.C. Motor-Operated Time-Delay  
 Relays (Heyl) ..... 102 Sept.  
 F. M. Radio Relay (Lee)..... 54 Dec.

**SERVICE**

All-Feminine Service Shop (Latimer) 100 Sept.  
 Answers to RETA Membership  
 Examinations ..... 102 July  
 Constructing a Heavy-Duty Output  
 Transformer (Hurlbut) ..... 35 July  
 Converting a Battery Set to AC  
 Operation (Boles) ..... 68 June  
 Dad's Advice to G.I. Joe (Paige)... 28 Apr.  
 Emergency Radio Receiver Tests  
 (Distelhorst) ..... 36 Apr.  
 For the Service Shop (Conklin).... 64 July  
 G. I. Plans for Postwar Shop  
 (Hetrick) ..... 46 Apr.  
 "Juke Box" Servicing Proves  
 Successful (Conklin) ..... 78 Aug.

Killion's Wartime Plans (Conklin)... 68 Apr.  
 Line Cord Voltage Bank (Davidson).100 Aug.  
 Louis Webb Charts Present-day  
 Service Procedure (Conklin)..... 83 May  
 Pentode vs Triode Operation (Brier).104 Dec.  
 Postwar Plans for the Radio Dealer  
 (Conklin) ..... 64 June  
 Radio Serviceman Plans for Postwar  
 Operation (Latimer) ..... 88 July  
 Reaching the Ruralist (Latimer).... 82 Oct.  
 Servicemen Are Organizing (Dale). 38 Mar.  
 Servicemen's Guide to Priority  
 Purchasing (Carrington) ..... 40 Apr.  
 Service Now—Sales Later (Tunnell). 64 Jan.  
 Servicing Auto Radios (Kiver)..... 28 Mar.  
 Servicing Hints on Auto Radio  
 Interferences (Kay) ..... 48 Apr.  
 Sidelines for the Radio Serviceman  
 (Graf) ..... 36 July  
 The Rural Radioman (Winters).... 36 May

**SOUND (ACOUSTICS, ETC.)**

Four Channel Mixer for your  
 Amplifier (King) ..... 110 Oct.  
 Microphone Input Circuit (Campbell) 49 Jan.  
 Phasing of Loud Speakers (Cook)... 30 Apr.  
 Servicing Public Address Equipment  
 (Moody) ..... 46 Jan.  
 Tone Control Circuits (Hoadley).... 46 Aug.  
 Unique Volume Expander and  
 Compressor (Stevens) ..... 50 July  
 Wartime Speaker Enclosures  
 (Hoadley) ..... 48 July

**SHORT WAVE LISTENER**

International Short-Wave (Boord)—58 Jan., 56  
 Feb., 56 Mar., 54 Apr., 47 Oct., 45 Nov.,  
 52 Dec.

**TELEVISION**

An Introduction to Television (Noll). 50 Jan.  
 Antennas for Television Receivers  
 (Noll) ..... 40 May  
 Color Television (Ehrlich)..... 32 July  
 Design of Television Receivers  
 (Sobel) ..... 35 Mar.

**AMATEURS  
 AND  
 RADIO REPAIRMEN**

---

**NORTHERN INDIANA'S NEWEST  
 WHOLESALE DISTRIBUTOR**

**FOR  
 NATIONAL AND R.M.E.  
 RECEIVERS**

(Place Orders for Immediate Delivery)

Hickok—Test Equipment  
 Premax—Ten Meter Verticals  
 Aerovox—Resistors & Condensers  
 Eimac's New 4-125A Tubes  
 Turner—Microphones

**EXCLUSIVE DISTRIBUTORS  
 FOR STROMBERG-CARLSON  
 AMPLIFIERS**

*Stanton Radio Supply*  
**W9PSP W9JKE**  
**521 State St., HAMMOND, INDIANA**



Functions of Video Circuit (Noll)....	48	Dec.
Television—As I See It (deForest)...	35	Jan.
Television for Future Airway Traffic Control (Morse) .....	38	Jan.
Television—for Industry and Home (Baltin) .....	53	Jan.
Television for the Amateur (Read, W9ETI) .....	35	Aug.
Television I.F. Systems (Noll).....	52	July
Television Industry Prepares for Postwar (Carmine) .....	43	Jan.
Television in Great Britain (Laden). ..	32	Jan.
Television Is Coming to the Smaller Cities (Lescarbourea) .....	29	Jan.
Television Receiver Design (Kiver)...	40	Jan.
Television R. F. and I. F. Systems (Noll) .....	50	June
Television Sound Channel (Noll)....	52	Aug.
Television Transmitting Equipment (Noll) .....	46	Mar.
The Television Channel (Noll).....	46	Feb.
The Television Receiver (Noll).....	32	Apr.
Video Amplifiers (Noll).....	57	Oct.

**TESTING**

Electrolytic Capacitor Checker (Turner) .....	38	Oct.
Emergency Radio Receiver Tests (Distelhorst) .....	36	Apr.
Testing Crystals (Jeltrup).....	44	July
The Oscilloscope Applied to Transmitter Checking (Eddy & Howard) ..	32	Oct.

**THEORY**

Constructing a Heavy-Duty Output Transformer (Hurlbut) .....	35	July
Practical Radio Course (Ghirardi) Part 30—Spurious Superheterodyne Interference .....	44	Jan.
Part 31—Spurious Superheterodyne Interference .....	52	Feb.
Part 32—Superheterodyne Oscillators .....	64	Mar.
Part 33—Superheterodyne Oscillators .....	50	Apr.
Part 34—Oscillator Circuits .....	50	May
Part 35—"Tracking" Superheterodynes .....	46	June
Part 36—"Tracking" Superheterodynes .....	48	Aug.
Part 37—"Tracking" Superheterodynes .....	48	Sept.
Part 39—Pushbutton Tuning .....	56	Dec.
The Cathode Follower (Hendriks)...	54	Feb.
Theory and Application of U.H.F. (Kiver)—		
Part 9—Coupling Methods .....	58	Feb.
Part 10—Electric Fields .....	57	Apr.
Part 11—Magnetic Fields .....	57	June
Transformer Theory (Wehrmann)...	35	Sept.
What Makes the Plate Current Dip? (Falquier) .....	118	July

**TRAINING**

Air Corps Radio Phraseology Training (Susan) .....	70	Jan.
Classroom Chores 10,000 Feet Up (Kent) .....	56	May
Radio Jobs for G.I. Joe (Wayne)...	25	Nov.
Training with Visual Aids (Winter) ..	41	Oct.

**TRANSMITTERS**

Build This Victory Transmitter (Dexter) .....	30	Aug.
Captured 1000 Watt Jap Transmitter ..	96	Oct.
450 mc. Microwave Transmitter (Frank, W9JU) .....	38	May
Frequency Modulated Transmitters (Newman) .....	38	June
Generating R. F. at 600 mc. (Maron) ..	51	Sept.
Multi-Band 30 Watt Transmitter (Silver) .....	48	Feb.
100 mc. Transmitter (Maron).....	42	Aug.
Television Transmitting Equipment (Noll) .....	46	Mar.

**TUBES**

The Saga of the Vacuum Tube (Tyne)—		
Part 15 .....	54	Jan.
Part 16 .....	52	Mar.

# PLUGS and JACKS

**...for every known application!**

Built in accordance with latest Signal Corps and Navy specifications, Amalgamated Plugs and Jacks are tropicalized to make them fungus resistant, waterproof and moistureproof when called for. Insulators of these components are designed to withstand extremes of temperatures for  $-67^{\circ}\text{F}$  to  $+167^{\circ}\text{F}$ , at humidities up to 100%. We also specialize in producing Plugs which will bear up under the high heat met in rubber molding cord sets.



**NOTE:** Amalgamated Engineers will gladly consult with you on the design and development of Plugs and Jacks for special applications—present or postwar.



**PLUG PL-55 and JACK JK-26, N.A.F. 1136-1**

Long sleeve, two-conductor plug, mate to Jack JK-34-A. Withstands minimum of 60 cycles AC, potential of 500 volts effective, applied between any two terminals for not less than two seconds. Meets minimum insulation value of 2000 megohms between conductors at  $68^{\circ}\text{F}$  at humidities up to 100%.



**JACK JK-26, N.A.F. 215284-2**

Two-conductor Jack, mate to PL-54. Tropicalized. Withstands 60 cycle AC potential of 500 volts effective, applied between any two terminals for not less than two seconds. Meets minimum insulation value of 2000 megohms between conductors at  $68^{\circ}\text{F}$ , at humidities up to 100%.



**PLUG, STYLE "A"**

Two-conductor, special type plug for use with Neoprene or Buna S molded cords. Same specifications as PL-55.



**JACK JK-48**

Light duty, two-conductor Jack, mate to Plug PL-291 and Plug 291-A.



**PLUG PL-204**

Hand set. A special plug wherein both a modified plug, PL-55 and PL-58, are held in place by a phenolic case. Same specifications as PL-55 and PL-66.



**PLUG PL-54, PL-540, PL-354, N.A.F. 215285-2**

Short sleeve, two-conductor plug, mate to Jack JK-26. Same specifications as PL-55.



**PLUG, STYLE "D"**

Two-conductor, special type plug for use with Neoprene or Buna S molded cords. Same specifications as PL-55.

**AMALGAMATED RADIO TELEVISION CORP.**

476 BROADWAY • NEW YORK 13, N. Y.



# THERE IS ONLY ONE RIGHT WAY TO TRAIN FOR TELEVISION

**FIRST:** See Television.

**SECOND:** Learn television from engineers who work in the industry.

**THIRD:** Train with real up-to-the-minute television broadcasting and receiving equipment. Be expert in servicing, operating, and engineering, so that you are capable of taking a job in the industry.

**FINISH:** By working with real television studio production experts with actual performances and with television manufacturing engineers in a large, up-to-date laboratory, so that you can become expert in the branch of television you are most capable of following. This is the right way to get into television and the way of

**AMERICAN TELEVISION  
LABORATORIES, INC.**

433 E. Erie St., Chicago 11, Illinois

Where there are day or evening classes,  
full or part time

A NATIONAL ORGANIZATION  
APPROVED FOR GI TRAINING

AMERICAN TELEVISION INSTITUTE  
Division of American Television Laboratories, Inc.  
433 E. Erie Street  
Chicago 11, Illinois

Please send me information regarding television training.

Name.....Address .....

City.....State .....

## CLARK RADIO EQUIPMENT CORPORATION

### CUSTOM BUILT AUDIO EQUIPMENT

- Preamplifiers
- Monitor Amplifiers
- Recording Amplifiers
- Commercial Playback Turntables
- Commercial Recorders
- Labyrinth Type Speakers
- Public Address Amplifiers
- Coil Winding

4313 North Lincoln Avenue  
Chicago 18, Illinois  
Lincoln 1747

Part 17 .....	58	May
Part 18 .....	56	July
Part 19 .....	54	Sept.
Part 20 .....	51	Nov.
Tube Substitution Chart (Crane)....	51	Apr.

### U. H. F.

The Future of U. H. F. (Laden)....	25	June
Theory and Application of U. H. F. (Kiver)—		
Part 9—Coupling Methods .....	58	Feb.
Part 10—Electric Fields .....	57	Apr.
Part 11—Magnetic Fields .....	57	June
Transmission Lines at 200 mc. (Garretson) .....	28	Feb.
Wave Guides (Mallory).....	36	Dec.
Let's Talk Shop (Marty)—51 Feb., 51 Mar., 45 Apr., 48 May, 45 June, 45 Aug., 44 Sept., 35 Dec.		
QTC (Coleman)—57 Jan., 60 Feb., 55 Mar., 56 Apr., 55 May, 56 June, 55 July, 55 Aug., 50 Sept., 56 Oct., 43 Dec.		

—30—

### International Short-Wave (Continued from page 110)

burg, operating on a frequency of 6.020, 49.8 meters, by authority of the Chief Signals Officer of the U.S. Army." A New Delhi frequency of 11.71 is reported in English at 8:30 a.m.; heterodyned by WLWK. Addis Ababa, Ethiopia, 9.620, relays BBC news at 11 a.m.; fair signal in Australia.

London's high frequencies, GSH, 21.470; GSJ, 21.530; GVR, 21.675; and GSK, 26.100, are being heard with good signals in the East around 8 a.m. London's Pacific service is now heard at new hours, 1-5 a.m.

A domestic relay is reported from OIX5, 17.801, Lahti, Finland, 8 a.m.-12:30 p.m.; suffers severe interference from Cincinnati on the same frequency.

HVJ, Vatican City, has been reported with test programs to Mexico on 17.740 at 12-12:18 p.m. and on 15.120 at 12:30-12:45 p.m. Have also used 15.120 and 11.740; excellent signals in East.

A late report indicates that the 2:15 a.m. transmission from Dakar, French West Africa, is now being radiated on 7.210 and 6.917, the latter having replaced the 11.715 frequency which was used for a while.

Although reports have come in during recent months on reception of *Radio Funchal*, 7.095, a letter received by an Eastern DXer from the proprietor of station CS2ZV, Funchal, Madeira, states there has been a ban on broadcasting from Madeira during the war and that no station is or has been operating as Radio Funchal. With the war's end, Funchal may return to the air.

*Sharq el Adna*, 6.135, Jerusalem, Palestine, is reported fair nightly, 11 p.m.-12 midnight; Jaffa, 6.170, reported heard in French, to 4 p.m., announcing as *Radio Palestine*, but seemed to be one of the "Sharq el Adna" transmitters.

Guam's KU5Q was due to close down around November 1, but remained on to relay Shanghai to American net-

works. By this time, however, all Guam frequencies may have been discontinued. Shanghai may now be relayed by Manila transmitters, which were relaying XGOO part of the time as early as late October.

Latest schedule reported on *Voice of America in North Africa* (American sources) is 6.040, 12:30-6 p.m.; 9.610, 1:45-6 p.m.; and 11.760, 6 a.m.-1:30 p.m. *Radio France*, 12.120, Algiers, heard with good signals, 12 noon-6 p.m.; no longer is relaying Prague as it did during early fall by mistake!

*Radio National Belge*, Leopoldville, Belgian Congo, has been changing frequencies slightly and often; latest frequency reported is 9.740; verifies with call listed as OTC.

British Guiana's ZFY, 6.000, Georgetown, has been heard this winter signing off at 7:20 or 7:30 p.m.; good signals usually in the East, both early mornings and early evenings.

Sofia, Bulgaria, on 9.300 is reported 12 midnight-1:10 a.m.

WVL, 2.380, Quarry Heights, Canal Zone, may be on 2.390 now; being heard with poor signals, 10:28 to sign-off at 11:05 p.m.

SUV, 10.055, Cairo, Egypt, heard to sign-off at 3:37 p.m. (Harris)

Listed schedule of OIX5, 17.800, Lahti, Finland, is 1:30-2, 5-5:40 a.m.

HH2S, 5.947, Port-au-Prince, Haiti, has been heard opening in French at 6:30 p.m.

ICD, 16.385, Rome, Italy, reported used to American networks, irregularly, usually at 8-8:15 a.m.

*Radio Tananarive*, 12.127, Madagascar, signs off at 8:45 a.m., reported best around 7:30 a.m.

XEBR, 11.820, Hermosillo, Mexico, verifies with a white card displaying a map of Mexico in blue.

YNQ, 6.915, Managua, Nicaragua, *La Voz de la Victoria*, verifies by air-mail letter, and is not using YNQW call as given in official lists for this short-wave transmitter; address is Apartado 338.

A Jaffa, Palestine, station on 6.790 was heard in late summer testing 1:30-4 p.m., announcing as the *Near East Broadcasting Station*.

Stockholm's SBT, 15.155, is listed 6-6:50 a.m. and 10 a.m.-1:15 p.m. weekdays; Sundays, 2:45 a.m.-1:15 p.m. We have been hearing this station almost daily, but only at 10-10:55 a.m.

From Europe comes a report that HVJ, 9.550, Vatican City, has English news at 1:15 p.m. Also has been heard in the East, testing, 12-12:45 p.m. on 17.840, where it suffers heavily from Radio Eirrean on same frequency.

Belgrade has been reported as heard irregularly on 6.150, usually 4-6 p.m.; and on 9.420, 12 midnight to fade-out around 2 a.m.; no longer uses 9.505.

### ACKNOWLEDGEMENTS

AUSTRALIA—Maher, Gillett; CALIFORNIA—Dilg, Balbi, Curtiss, Cole, Noyes; CANADA—International Service, CBC, the Rogers Broadcasting Co., Ltd., CHNS (Nova Scotia); COLORA-

**RADIO NEWS**



DO—Woolley; DISTRICT OF COLUMBIA—Netherlands Information Bureau, West Indian Radio Newspaper, U.S. Dept. of Commerce, Post Office Dept.; ILLINOIS—Johnson, Anderson; INDIANA—Green, Hoiermann; KANSAS—Steinmetz, Seckler; MASSACHUSETTS—Harris, Horton, Kernan; NEW JERSEY—Garrison; NEW YORK—Kentzel, Hayman, Australian News & Information Bureau, BBC, Bogdan; NEW ZEALAND—Milne; NORTH CAROLINA—Miller; OHIO—The Crosley Corporation; OREGON—Morris; PENNSYLVANIA—Black; SOUTH AFRICA—South African Broadcasting Corporation; SWITZERLAND—Schweizerischer Rundspruchdienst, Bern; TEXAS—Freund, Giles; VIRGINIA—Howe, URDXC; WASHINGTON—Hanson, Brott; WEST VIRGINIA—Gonder.

—30—

**Spot News**

(Continued from page 14)

in acquisition or distribution costs, OPA said, but served merely to increase margins abnormally.

Through customary retail practices of giving substantial discounts for cash payments, generous allowances for trade-ins, and mark-downs at periodic bargain sales, consumers normally paid considerably less in prewar years than the retail prices listed in the manufacturers' catalogs. But during the early

months of the war, when production was curtailed and consumer buying power had begun to increase, retail selling prices of many consumer goods gradually rose to the higher levels represented by the manufacturers' lists, OPA explained. Many of these increases took place before the price agency was authorized to impose controls.

List prices, not actual prewar selling prices, are the basis of the retail ceilings that have prevailed during the war, OPA said. On the other hand, increases now being granted to manufacturers are based on their costs and sales prices in the months before material scarcities and higher production costs had driven prices above normal peacetime levels. Furthermore, the manufacturer increases granted do not compensate for all cost increases since the beginning of the war, OPA explained, but normally require a certain amount of cost absorption on the part of the manufacturer.

For these reasons, and because sellers can now look forward for many months to an increasing volume of goods and a steady demand for all items, distributors and dealers should be able to absorb without substantial hardship the increases over 1941 prices that are granted to manufacturers, OPA pointed out.

Manufacturer pricing methods established by OPA are as follows:

On models the same as those produced from July to October 1941 the

manufacturer computes his reconversion price on the basis of his established prices to distributors, or to dealers if he did not sell to distributors.

Old price ranges and increases that may be added by manufacturers who sold through distributors are as follows: where established price to distributors is \$11 or less, allowed increase on sales is 15 per-cent; where it is between \$11 and \$30, allowed increase is 12 per-cent or \$1.65, whichever is more; where established price is over \$30, allowed increase is 10.5 per-cent or \$3.60, whichever is more.

If the manufacturer dealt only with dealers in the base period, he computes his new ceilings to dealers as follows: where established price to dealers is \$13 or less, allowed increase on sales is 15 per-cent; where it is between \$13 and \$35.41, allowed increase is 12 per-cent; where established price is over \$35.40, allowed increase is 10.5 per-cent.

OPA may withdraw reconversion price increases from manufacturers who fail to maintain approximately their prewar "product mix"—that is, the proportion of low and medium priced models to those in the higher price brackets.

**ANNOUNCEMENT HAS JUST BEEN MADE** by the Signal Corps of the development of an electronic impulse-noise generator for use in calibrating the impulse-noise sensitivity of radio receivers. Work on the proj-

**Here is how you can acquire a better knowledge of electronics without trying to be a radio engineer . . .**

**... SEND FOR** *Elementary Engineering Electronics*

**With Special Reference to Measurement and Control**

by *Andrew W. Kramer,*

Managing Editor *Power Plant Engineering,*  
Member American Institute of Electrical Engineers,  
Associate Member Institute of Radio Engineers

**Cloth, 344 pages, 259 illustrations—\$2.00 postpaid**

This is a **PRACTICAL** treatment of principles and applications. It is **NON-MATHEMATICAL**—no equations beyond elementary-algebra level in the text—fewer than a dozen of these to be learned.

**ORDER THIS UNIQUE BOOK NOW**

Check, money order or cash must accompany order.

-----  
Instruments Publishing Co., 1119 Wolfendale St., Pgh. 12, Pa.

Enclosed is \$..... for ..... copies of Kramer's **ELEMENTARY ENGINEERING ELECTRONICS** (at \$2 each).

Name .....

Address .....

*Instruments* THE MAGAZINE OF *Measurement and Control*

**SUBSCRIBE NOW!**

-----  
Instruments Publishing Co., 1119 Wolfendale St., Pgh. 12, Pa.  
Enclosed is \$2.00 for which send me *Instruments* for **ONE YEAR.**

NAME .....

Position .....

Company .....

Products .....

ADDRESS .....

This unique magazine offers a **BALANCED DIET** of articles and special features appealing to production men as well as to research men—to executives and apprentices! It covers all subjects within the growing fields of Measurements, Inspection, Testing, Automatic Control, Metering, etc.

Many important methods have been disclosed for the first time in exclusive *Instruments* articles; many more will be disclosed through its pages.

Several outstanding books appeared first as serials in *Instruments*. The one advertised above is but one example.



**Just Off the Press!**  
**OUR NEW RADIO &  
 ELECTRONIC PARTS  
 CATALOG**

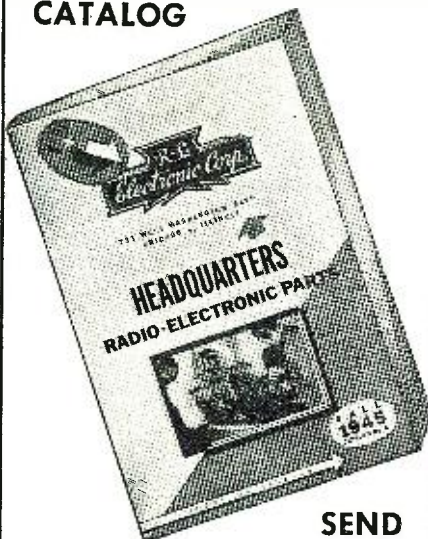

**SEND  
 FOR FREE COPY TODAY**



731 West Washington Boulevard  
 Chicago 6, Illinois

**FOR IMMEDIATE DELIVERY!**

**RECORD PLAYERS**

**COMPLETE—SIMPLY INSTALL  
 YOUR OWN  
 MOTOR AND  
 TURNTABLE!**



**Record Player  
 Complete  
 without motor  
 & turntable  
 \$3250  
 per unit**

**PLAYER  
 CONTAINS:**

- Large electro-dynamic speaker
- Tone Control • Volume Control
- A. C. Amplifier with power transformer, and connecting cords
- 3 tubes—1-6V6, 1-6C5, 1-5Y3
- Astatic pickup with arm rest
- Permanent needle—Knobs
- Acoustically-built cabinet
- All in a handsome, leatherette-covered, sturdily-constructed case, 14" wide, 7½" high, 16¾" long.

**DEALERS—Write for quantity discounts!**

**UNION RADIO CORPORATION**  
 1636 W. VAN BUREN ST., CHICAGO 12, ILL.

ect was conducted at the *Detroit Signal Laboratory* under the direction of Hunter C. Goodrich, assignment engineer. It is believed that the new generator will have important commercial applications. It may be used to measure in absolute terms receiver impulse-noise susceptibility—an important receiver characteristic, particularly in frequency-modulation and television receivers, which in the past has not been adequately defined for lack of a suitable noise generator. It may also be used in the gain standardization of field-strength meters of fixed bandwidth; and in production receiver testing, for making sensitivity tests continuously over the frequency range of the receiver. Assisting Mr. Goodrich in the development and testing of the impulse noise-generator were Mrs. I. L. Lutzier of the *Detroit Signal Laboratory* and Dr. J. E. Gorham, I. Sager, and other personnel of the *Evans Signal Laboratory*.

—30—

**Practical Radio Course**

(Continued from page 62)

lator drift upon the reception, depends upon whether the receiver is designed to operate with its oscillator frequency *higher* than that of the incoming signal, or *lower*.

Examination of Fig. 3 will make this clear. Superheterodyne operation with the oscillator frequency ( $f_o$ ) *higher* than that of the incoming signal ( $f_s$ ) by an amount equal to the i.f. employed in the receiver (455 kc. in this case) is illustrated at (A). Operation with the oscillator frequency *lower* than that of the incoming signal by the same amount is illustrated at (B).

For the condition of (A), if a rise in the ambient temperature causes physical changes in the oscillator tuning coil and capacitors that makes their resonant frequency *lower*, the oscillator frequency will drift correspondingly lower, to the value represented by the dotted line  $O_1 - O_2$ . Since  $f_i = f_o - f_{sig}$ , this reduces the frequency of the i.f. carrier by this same amount. Simultaneously, the rise in the ambient temperature also causes physical changes in the tuning coils and capacitors of the i.f. amplifier (though not necessarily the same amounts as in the oscillator), so its resonance frequency drifts to some lower value, thereby tending to accommodate itself to the i.f. carrier of lowered frequency. This can be visualized by imagining the i.f. amplifier resonance curve in (B) of Fig. 2 shifting to the left a certain amount each time the oscillator frequency (and i.f. carrier frequency) drifts lower (shifts to the left). In effect then, the frequency drift of the i.f. amplifier tends to partially compensate for the drift of the oscillator frequency, when *high-side* oscillator operation is employed.

**CURRENT  
 CONVERSION  
 WITH ATR  
 QUALITY PRODUCTS**



**ATR "A"**

**BATTERY ELIMINATORS**

For Converting A.C. to D.C.

Designed for Testing D.C. Electrical Apparatus on Regular A.C. Lines. Equipped with Full-Wave Dry Disc Type Rectifier, Assuring Noiseless, Interference-Free Operation and Extreme Long Life and Reliability.

- Eliminates Storage Batteries and Battery Chargers.
- Operates the Equipment at Maximum Efficiency at All Times.
- Fully Automatic and Fool-Proof.

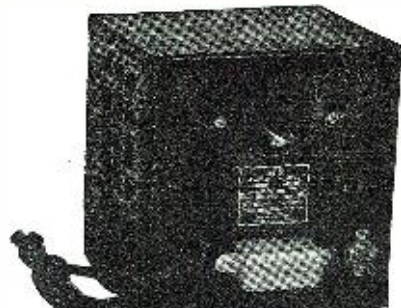

**ATR LOW  
 POWER  
 INVERTERS**

For Inverting D.C. to A.C.

For Operating Small A.C. Motors, Electric Razors, and a Host of Other Small A.C. Devices from D.C. Voltage Sources.



**STANDARD AND  
 HEAVY DUTY  
 INVERTERS**

For Inverting D.C. to A.C.

Specially Designed for Operating A.C. Radios, Television Sets, Amplifiers, Address Systems, and Radio Test Equipment from D.C. Voltages in Vehicles, Ships, Trains, Planes, and in D.C. Districts.

**WRITE for LATEST ATR CATALOG—  
 Just off the press!**

**AMERICAN TELEVISION & RADIO CO.**  
 Quality Products Since 1931  
 ST. PAUL 1, MINN. U. S. A.



What happens when the oscillator is operated at a frequency *lower* than that of the signal is illustrated at (B) of Fig. 3. Ambient temperature rise causing the oscillator frequency to drift from its original value to lower value  $O_1 - O_2$ , causes the *difference* between the signal frequency and the oscillator frequency to *increase*. Since this difference represents the frequency of the resulting i.f. carrier, its frequency is now higher than before. Meanwhile, the rise in the ambient temperature causes the resonant frequency of the i.f. amplifier to *decrease*. Accordingly, since a change in ambient temperature that causes the frequency of the i.f. carrier to increase now simultaneously causes the resonant frequency of the i.f. amplifier to decrease, the i.f. amplifier becomes more and more mistuned to the i.f. carrier. Accordingly, for this type of superhet operation, drift in the i.f. stages adds to the harmful effect of drift in the oscillator frequency. This can be visualized by imagining the amplifier resonance curve (A) of Fig. 2 to shift to the left while the i.f. carrier frequency simultaneously shifts to the right.

In the discussions that follow here, it will be assumed that the oscillator is being operated at a frequency *higher* than that of the signal, for this is the mode of operation most frequently employed. When so operated, any drift occurring in the resonant frequency of the i.f. amplifier will tend to at least partially compensate the simultaneous drift occurring in the oscillator frequency. The net amount of drift resulting will be referred to as the *net osc.-i.f. drift*. The extent to which the i.f. amplifier drift normally tends to compensate the oscillator drift depends, among other things, upon the relative frequencies of the oscillator and the i.f. amplifier. Since the oscillator frequency always is considerably higher than the resonant frequency of the i.f. amplifier, the percentage drift occurring in the i.f. amplifier must be considerably larger than that occurring in the oscillator if they are to be numerically equal (in kc.) so that they compensate each other fully. Furthermore, since the i.f. amplifier employs fixed-frequency tuning circuits, a given increment of temperature will normally cause a definite amount of frequency drift in it. On the other hand, since the oscillator employs a variable-frequency tuning circuit, its normal drift in kc. per given increment of temperature is rarely constant over its entire tuning range. Consequently, the i.f. amplifier drift could only be made to compensate the oscillator drift exactly at some *one* oscillator frequency, unless it were possible to give it a special temperature characteristic.

Although designing the receiver to employ an oscillator frequency *higher* than the signal frequency will produce only a partial correction of the effects of oscillator frequency drift, it

# SOUND VALUES at TERMINAL RADIO

## University REFLEX PROJECTORS



IN STOCK—IMMEDIATE DELIVERY

- Weatherproof and Shockproof
- Easily Handle 25 Watts Audio
- Heavy Duty Driver Units
- Preferred by Leading P.A. Men

Will project sound up to 1/2 mile. Extremely rugged construction, 100% waterproof. Non-resonant rubber rims with each unit. Furnished with universal mounting brackets, Battleship grey finish.

### Model LSAH

4 1/2 ft. air column, 25 inch bell diameter. Frequency response 70-5000 cps, 115 cps cut-off. 15 ohm voice coil, 25 watts. Complete with mounting bracket and rubber rim ..... **\$42.47** net

### Model PSAH

3 1/2 ft. air column, 21 inch bell diameter. Frequency response 70-5000 cps, 140 cps cut-off. 15 ohm voice coil, 25 watts. Complete with mounting bracket ..... **\$33.65** net

For extra heavy duty driver unit, add \$11.76 to cost of either speaker

### High Efficiency ANNOUNCING SPEAKER

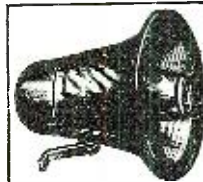

Ideal for high power paging. Extremely high projecting power due to high reflex efficiency. Handles 12 watts, yet size only 9" x 9". 8 ohm voice coil.

Complete with mounting bracket and rubber rim ..... **\$15.52** net

### Utah "GIANT" PM SPEAKER

For high power and high quality sound installations. Handles 22 watts normal, 33 watts peak. 7 pound magnet. 8 ohm voice coil. 12" diameter for standard mounting ..... **\$28.46** net

Other Utah Models in Stock

### We Have the Microphone You Need!

Terminal carries a large stock of Astatic, Brush, Amperite, American, Shure, Turner, Electro-Voice, and Universal microphones for all amateur, broadcast, public address and recording requirements.

#### FOR HAMS! P.A.! RECORDING!

TURNER VT-73—crystal microphone, complete with stand and 7 ft. cable. High output, ball swivel head ..... \$11.76 net	SHURE 707A—general purpose crystal microphone, die-cast case finished iridescent grey. Complete with 7 ft. cable, less stand ..... \$7.94 net
ASTATIC JT-30—crystal microphone, complete with stand and shielded cable. Excellent response at low cost ..... \$9.11 net	ELECTRO-VOICE 2105—High quality single button carbon type in weatherproof phenolic housing. Press-to-talk switch ..... \$10.28 net

### Terminal FLOOR STANDS

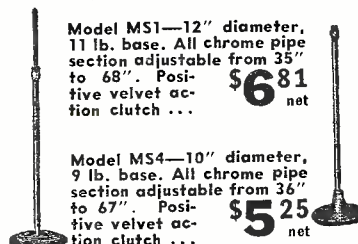

Model MS1—12" diameter, 11 lb. base. All chrome pipe section adjustable from 35" to 68". Positive velvet action clutch ..... **\$6.81** net

Model MS4—10" diameter, 9 lb. base. All chrome pipe section adjustable from 36" to 67". Positive velvet action clutch ..... **\$5.25** net

### Brush "HUSHATONE"

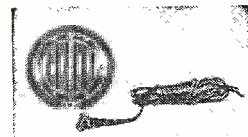

Small plastic extension speaker for under pillow use. Excellent tone quality. Hermetically sealed. No parts to wear, loosen or become detached. Complete with 6-ft. cord ..... **\$7.20** net

# Terminal Radio Corporation

85 CORTLANDT STREET, NEW YORK 7, N. Y. Telephone WOrth 2-4415



**ATTENTION!**  
STUDENTS • SERVICE MEN • HOSPITALS

*Build Your Own*  
**RADIO**

*It's Easy . . . We Show You How*

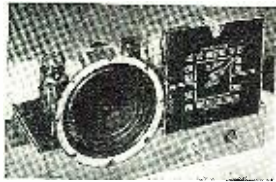

We manufacture complete radio kits. Send for details.

Four tube T.R.F. Kit complete with tubes . . . . . **\$10.95**

Six tube Superheterodyne Kit complete with tubes . . . . . **\$17.95**

**MULTI-TESTER**

All the parts you need plus complete detailed instructions to enable you to build a multi-tester which parallels commercial meter construction . . . . . **\$14.95**

*Special for This Month*  
**Pocket ohm-volt Milliammeter**  
**\$7.95**

Available at Once  
**GOVERNMENT SURPLUS**  
Transmitters. Receivers  
Test Equipment

We carry a complete stock of parts.  
Export inquiries invited.

**RADIO KITS COMPANY**

Dept. K 120 Cedar St. New York 6, N. Y.

**CAREER RADIO**

**THREE INTENSIVE COURSES**

Each one a chance for ambitious men and women to increase earning capacity and promote permanent employment.

**1. RADIO TECHNICIAN**

A general course including FM and Television. Students learn by constructing electronic and radio equipment under expert supervision.

**2. RADIO COMMUNICATIONS**

Prepare for FCC licenses. Includes telegraphy. Leads to position as merchant marine or flight radio officer.

**3. AIRLINE COMMUNICATOR**

NON-TECHNICAL. Of special interest to YOUNG WOMEN. Prepares for employment in airport flight control offices. Qualified Veterans may enroll under GI Bill or Public Law 16. Licensed by State of New York. VISIT, PHONE OR WRITE FOR DETAILS

**MELVILLE RADIO INSTITUTE**

"the radio school managed by radio men"

**CLIP THIS COUPON**

Send Me Free Information

- Check  ★ Radio Communications  
One  ★ Technical Radio  
NAME   
ADDRESS

**MELVILLE RADIO INSTITUTE**  
45 WEST 45th ST. NEW YORK 19, N. Y.

still is important, since it is well to have all factors work toward improving conditions rather than making them worse.

**Allowable Frequency Drift in AM, FM, and Television Receivers**

Since AM sound broadcasting services employ bands of 5 or 7 kc. width on each side of the carrier frequency, a net oscillator-i.f. drift as great as 10 kc. in receivers for these services is usually large enough to tune the receiver completely away from the desired signal (and possibly on to that of an undesired adjacent-channel station) if i.f. amplifiers having the ordinary selectivity characteristics for such receivers are used. It is evident, therefore, that even much less drift than this would be objectionable in such receivers because of its harmful effects on the tone quality (see Fig. 2).

Television and FM (audio) services employ wider frequency bands and consequently do not require quite the high degree of oscillator-i.f. frequency stability (in kc.) of the foregoing example. The tolerance for FM broadcast band reception has been estimated to be 5 to 20 kc., and that for television reception, 20 to 50 kc. These tolerances, when applied to FM audio signals at 50 mc. and television signals up to 100 mc. indicate permissible oscillator-frequency deviations in the range of .01 to .05 per-cent. Receivers for such services must be capable of tuning to this order of accuracy, and of maintaining their oscillator-i.f. frequency thereafter within the tolerance considered to be acceptable.

If the receiver is of the manually tuned type, employing a conventional multi-gang variable tuning capacitor, the oscillator frequency, after having drifted, may be readjusted to the correct value by readjusting the tuning control slightly until the station is heard again at maximum volume and normal tone. The resonant frequency of the preselector (which likely has also drifted) may still be somewhat incorrect, but this will not affect the reception nearly as much as does a mistuned oscillator. If the receiver is of the push-button type, it will not be possible to bring in the station again at full volume and normal tone except by readjusting the oscillator tuning adjustment provided for that particular push-button. It is evident then that for either a manually tuned or a push-button tuned receiver the tuning would have to be readjusted each time the oscillator drift became large enough to spoil the reception. Since it would be very bothersome to have to readjust the tuning of a sound or television receiver (especially one of the push-button type) after each 5 or 10 minutes of operation in order to keep the signal tuned in, other more satisfactory remedies are employed. For example, special precautionary measures may be taken during design of the components of the preselector, oscillator, and i.f. stages to reduce or

famous for

**GREAT VALUES**

**IN RADIO**

- EQUIPMENT
- PARTS and
- SUPPLIES

Now . . . available at once . . . the greatest buys in Radio Parts and Products for the Serviceman, Dealer, and Ham. A vast line, headed by—

- Test Equipment ● Replacement Cabinets ● Vibrators ● Electrolytics (all kinds) ● Tubes ● Transformers ● Soldering Irons ● Radio Kits ● Ham Supplies.

PLUS . . . hundreds of other items for every repair, maintenance, and experimental need. All items fully guaranteed . . . made right and priced right. We ship anywhere in the U.S.A.—promptly!

**WRITE FOR OUR CATALOG NOW!**

**RADIO DEALERS SUPPLY COMPANY**

135 LIBERTY ST., NEW YORK 6, N. Y.

**ROEHR DISTRIBUTING COMPANY**

*St. Louis' Radio Mail Order House*

**TUBES**

**TRANSFORMERS**

**CONDENSERS**

**RESISTORS**

**SPEAKERS**

**MIKES**

**ANTENNAS, ETC.**

*Distributors for*

**BELL SOUND EQUIPMENT**

and

**TEMPLE RADIOS**

Write for our list of tubes.

**ST. LOUIS 3, MO.**



compensate the tendency toward overall frequency drift. These will be more easily understood after the various causes of oscillator frequency drift are made clear in the next lesson of this series.

(To be continued)

**Radio Relay**

(Continued from page 28)

sired, as many as 96 telegraph circuits may be substituted for the eight telephone circuits available. AN/TRC-6 provides transmission which is as quiet and distortionless as the best commercial telephone circuits available, and it is subject to very little static or atmospheric disturbance, because of its use of pulse modulation and a very high radio frequency.

The AN/TRC-6 operates in the frequency range between 4300 and 4900 megacycles, the super-high-frequency band. The wavelength is about half the length of an ordinary lead pencil. Because of its size and complexity the equipment is not intended for use in forward areas. It is used between armies and army groups and from army groups to rear areas. It provides principal means of communications with reliability and quality as good as those of wire circuits—in many cases, better.

This outfit employs a 57-inch parabolic aluminum reflector and an unusual antenna. The reflector is perforated with  $\frac{3}{8}$ " holes to cut wind resistance. The holes, incidentally, are sufficiently smaller than a wavelength so that the reflector retains all its electrical efficiency. The reflector is excited by a wave-guide feed, the antenna being inserted through a hole in the center. Since space does not permit a full discussion of all details of this and the other sets, only the antenna will be presented in some detail.

"The r.f. energy developed by the oscillator," you learn from Maj. R. R. Little, project officer for the California experiments, "is fed through a short length of waveguide to the antenna, where it is radiated into space as a directional beam toward the receiving station. The antenna consists of a wave-guide feed and a parabolic reflector. The parabolic reflector has the property of reflecting as a parallel beam all rays striking it from a source located at the focal point of the paraboloid. Moreover, the distances along all reflected rays measured from the source to a plane held squarely in front of the paraboloid are equal, regardless of what part of the curved reflecting surface they strike. The parabolic reflector therefore serves to concentrate the electromagnetic wave from the transmitter into a narrow beam, all portions of which arrive in phase at the distant receiver. The radio beam is similar to the beam of a searchlight and must be pointed accurately at the distant receiver.

"The source of electromagnetic waves at the focal point of the parab-

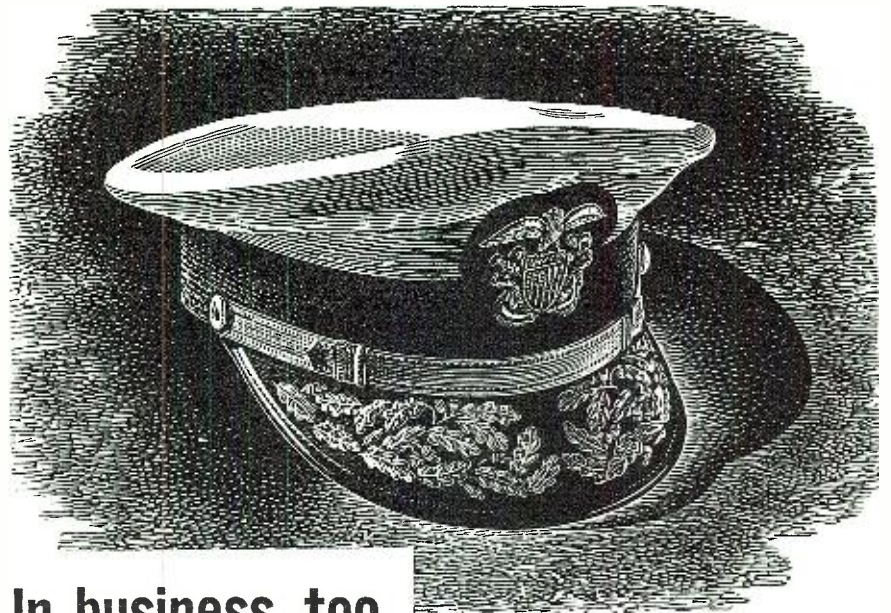

In business, too,

**TRAINED men reach the top!**

Like commissioned officers in our armed forces, business men and industrialists who "reach the top" have a working knowledge of *fundamentals*.

They know how the basic principles underlying business and industry operate; they understand marketing, accounting, finance AND production.

It is this broad knowledge which enables them to hold executive positions—to supervise the activities of specialists, technicians and others.

The Institute's Modern Business Course and Service is designed for men who recognize the obvious necessity of understanding all FOUR important departments of business and industry. It is practical, intensive and scientific!

With the help of Institute training, ambitious men can strengthen their present positions while preparing for bigger,

better jobs tomorrow.

Among the prominent men who have contributed to the Course are: Thomas J. Watson, President, International Business Machines Corp.; Frederick W. Pickard, Vice President and Director, E. I. du Pont de Nemours & Co.; Clifton Slusser, Vice President, Goodyear Tire & Rubber Co.

**Send For "Forging Ahead in Business"**

The Institute's story is factually told in the fast-reading pages of its famous little book, "Forging Ahead in Business." There is no charge for this booklet; no obligation involved. To men who are genuinely interested in self-improvement, "Forging Ahead in Business" has a message of distinct importance. Simply fill in and return the coupon below, and your FREE copy will be mailed to you promptly.

**ALEXANDER HAMILTON INSTITUTE**



Alexander Hamilton Institute  
 Dept. 352, 71 West 23rd St., New York 10, N. Y.  
 In Canada: 54 Wellington Street, West Toronto 1, Ont.  
 Please mail me, without cost, a copy of the 64-page book—  
 "FORGING AHEAD IN BUSINESS."

Name.....  
 Firm Name.....  
 Business Address.....  
 Position.....  
 Home Address.....





does it again!

## 2,160-inch Spool of SCOTCH TAPE

A money-saving miracle! 2,160 inches of genuine Scotch Brand paper-backed electrical and radio tape, approx. 1/2" wide. Sticks to any dry surface. Insulates turns on transformers, coils, radio parts, etc. Perfect for attaching paper to glass or any flat or curved surface. Our price is way below the actual value! (This offer good only in U. S. A.)

ONLY  
**50¢**  
POSTPAID

MAIL  
THIS  
COUPON  
TODAY

SEND FOR OUR FREE BARGAIN BULLETINS!

*Olson Radio Warehouse*

73 E. MILL ST., DEPT. 4, AKRON, OHIO

Send me \_\_\_\_\_ 2,160-inch spools of Scotch Tape at 50c each, postpaid. I enclose \$ \_\_\_\_\_

NAME .....

ADDRESS .....

## DEPENDABLE PERFORMANCE

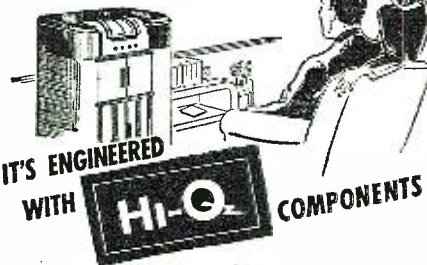

CERAMIC CAPACITORS

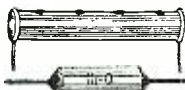

WIRE WOUND RESISTORS

CHOKE COILS



**ELECTRICAL REACTANCE CORPORATION**  
FRANKLINVILLE, N. Y.

loid is a small plane reflector in a resonant cavity at the end of the waveguide feed. The electromagnetic wave generated in the radio transmitter passes through the waveguide, and on reaching the end is directed out through the slotted end into the paraboloid.

"The advantage of highly directional transmission lies in the fact that the total power of the transmitter, which ordinarily would be scattered in all directions, is concentrated into a narrow beam pointed at the distant receiver. The receiving reflector functions in a manner similar to a telescope, with a gain in wave-gathering power over a nondirectional antenna equivalent to the gain of an identical reflector used for transmitting.

"The electromagnetic waves leaving the vacuum-tube oscillator are transmitted along the waveguide with their electric vector perpendicular to the long dimension of the rectangular cross-section. Since the waveguide is mounted with the long dimension vertical, the waves leave the waveguide feed and are transmitted into space with their electric vector in a horizontal plane.

"At the distant receiving antenna the horizontally polarized waves are focused on the opening in the waveguide feed and pass through the waveguide to the crystal detector with their electric vector horizontal—that is, perpendicular to the long dimension of the guide. If the respective planes of polarization of the waveguide feeds at the transmitter and receiver were crossed (one vertical and one horizontal), the waves polarized in one plane would not be transmitted through the receiving waveguide arranged for waves polarized in the other plane."

The first installation of AN/TRC-6, in January 1945, provided telephone facilities between 12th Army Group and 15th Army. When more equipment arrived in April, circuits were installed between 12th Army Group and 3rd Army, 6th Army Group, and 7th Army. As the 3rd Army advanced into Germany, constant communica-

Top cross-section view of antenna AN/TRC-5 and parabolic reflector.

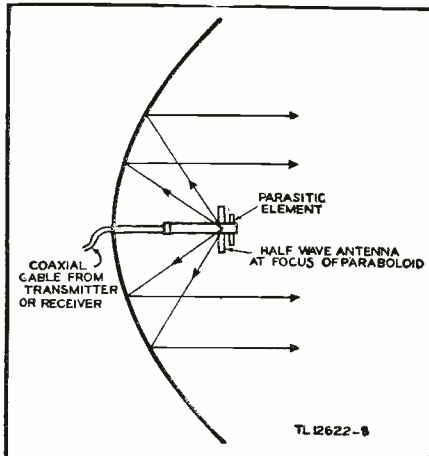

TL 12622-8

**Export for Profit**

Roburn Agencies, Inc. have represented leading manufacturers of radio and electrical equipment, parts and accessories, in world-wide markets since 1935. Extensive facilities relieve you of all export headaches — correspondence, advertising, sales, finance, packing and shipping. A few additional clients seeking experienced, reliable representation are invited. Write for information on Profits Through Exports.

**Roburn Agencies, Inc.**  
115W Fulton Street New York 7, N. Y.

**RADIO PARTS AND TUBES**  
AT NEW LOW PRICES  
SEND FOR OUR LATEST BARGAIN BULLETIN  
**PAPEL BROTHERS**  
2639 East Fourth St., Los Angeles 33, Calif.

## Amateur Radio WRITERS WANTED

To write articles on transmitters, receivers, antennas, test equipment, and any material of general interest to amateurs. Articles should be typewritten, between 2000 and 2500 words in length, accompanied by suitable diagrams, photos, and parts lists. Liberal payment made upon acceptance.

Address all communications to  
**Box 419**  
**RADIO NEWS**  
185 North Wabash Avenue, Chicago 1, Illinois



tions between it and 12th Army Group were maintained by AN/TRC-6, which was installed at each new location to which the army moved. The total distance by radio from 12th Army Group near Frankfurt, Germany, to 3rd Army in southern Germany was nearly 300 miles, using two terminals and three relay stations.

AN/TRC-5 performs functions identical to those of AN/TRC-6, but operates in an entirely different frequency range, 1350-1450 mc. It is somewhat smaller than AN/TRC-6. This equipment also provides eight high-quality telephone circuits. Production of these sets had barely started when the war ended, so none had been used in the fighting theaters. It is anticipated, however, that this set will be used by the occupation forces in Japan.

This set provides an excellent opportunity to consider further the theory of pulse transmission upon which it operates, and the principles upon which are founded its transmitter, antenna, and receiver.

The transmitting multiplex unit translates the v.f. signals of the eight voice-frequency channels into pulse-position-modulated, time division signals for transmission over the radio link. First, the multiplex generates a series of eight .4-microsecond channel pulses followed by a 2-microsecond synchronizing pulse. The eight channel pulses and the sync pulse are referred to as the sync period, and each sync period is repeated every 100 microseconds. Modulation of the eight channel pulses is accomplished by electrically scanning each of the v.f. circuits once during each sync period. Thus the position of each channel pulse in time, with respect to the sync pulse, can be varied during successive periods at a rate determined by the frequency of the modulating signal. The amount that the channel pulse is displaced from normal depends upon the amplitude of the modulating signal.

The transmitter converts the position-modulated, positive-going pulses into impulses of ultra-high-frequency power. The final waveform of the radiated impulses may be pictured as a recurrent series of nine short groups of oscillations, which may be in frequency from 1350-1500 mc. Each channel pulse is emitted from the antenna for a period of about .4 microseconds, and the sync pulse for 2 microseconds.

As for the antenna, each consists of a radiating element, a parasitic reflector, and a 50-inch parabolic reflector which results in a line-of-sight concentration of r.f. power.

The antenna assembly is essentially a half-wave dipole, fed at the center by means of a coaxial cable. The radiation resistance at the center of the dipole is approximately 50 ohms. The dipole support consists of a short length of coaxial cable used to supply r.f. energy to the dipole. Two r.f. chokes are placed around the coaxial cable and serve to balance the antenna dipole to ground; otherwise the dipole half connected to the outer con-



Jobbers told us, even before the first "VOMAX" had been shipped, that its unmatched specifications had instantly established it as the standard of comparison among their clients. Its outstanding superiority is its **completeness**. "VOMAX" makes you master . . . no longer victim . . . by at last giving you the ability to measure directly . . . accurately . . . every operating—and signal—voltage in radio receivers.

Not only does "VOMAX" measure every voltage . . . d.c., a.c., a.f., a.v.c., limiter, discriminator, power output. With it you can at last measure r.f. signal voltages up beyond 100 mcs. in actual receiver operation! Here is true visual dynamic signal tracing.

Read the brief specifications at the right and you'll see why "VOMAX" has been purchased by the military, universities, atomic bomb research laboratories, great industrial organizations and by thousands of wide awake service technicians.

Designed for precision laboratory use, tremendous sales enable us to still keep "VOMAX" price well below OPA ceiling. "VOMAX" measures every voltage directly . . . makes you the master . . . for only \$59.85.

## "VOMAX"

### Measures EVERY Voltage

1. Brand new post-war design . . . positively not a "warmed-over" pre-war model.
2. More than an "electronic" voltmeter, VOMAX is a true vacuum tube voltmeter in every voltage/resistance/db function.
3. Complete visual signal tracing from 20 cycles through over 100 megacycles by withdrawable r.f. diode probe.
4. 3 through 1200 volts d.c. full scale in 6 ranges at 51, and in 6 added ranges to 3000 volts at 126 megohms input resistance. Plus minus polarity reversing switch.
5. 3 through 1200 volts a.c. full scale in 6 ranges at honest effective circuit loading of 0.6 megohms and 8 mfd.
6. 0.2 through 2000 megohms in six easily read ranges.
7. - 10 through + 50 db. (0 db. = 1 mw. in 600 ohms) in 3 ranges.
8. 1.2 ma through 12 amperes full scale . . . 6 d.c. ranges.
9. Absolutely stable—one zero adjustment sets all ranges. No probe shorting to set a meaningless zero which shifts as soon as probes are separated. Grid current errors completely eliminated.
10. Honest, factual accuracy: ± 3% on d.c.; ± 5% on a.c.; 20 $\mu$  through 100 megacycles; ± 2% of full scale, ± 1% of indicated resistance value.
11. Only five color-differentiated scales on 4 3/4" D'Arsonval meter for 51 ranges (including d.c. volts polarity reversal) eliminate confusion.
12. Meter 100% protected against overload burnout on volts/ohms/db.
13. Substantial leather carrying handle. Size only 12 3/4" x 7 3/4" x 5 1/4".

Send postcard for free catalog of measurement and communication equipment.

OVER 34 YEARS OF RADIO ENGINEERING ACHIEVEMENT

*McMurdo Silver Company*

1260 MAIN STREET, HARTFORD 3, CONNECTICUT

LOCATES TROUBLE INSTANTLY  
IN ALL ELECTRICAL DEVICES



### HANLAN APPLIANCE TESTER

In this single unit are combined all the necessary tests for examining every appliance. Checks thermostats under actual working conditions. Tells instant it opens or closes. Controls the heat on soldering irons—prevents overheating. Tests continuity, open circuits, etc. Checks automatic irons, vacuum cleaners, motors, shavers, bulbs, fuses, appliances with 3-way switches, etc. Great time, effort and money saver! Only \$9.50

Pat. Pend.  
complete. WRITE FOR CIRCULAR. HANLAN Co.,  
1419-R West Jefferson Los Angeles 7, Calif.  
FREE with each Tester. New, Complete, Practical Course in electrical appliance repairing.

RADIO,  
ELECTRONICS  
and YOU!

THERE are big rewards in the communications line for the Radio man who has the answers! Too, the equipment that has made Radio communication possible is functioning now in other rewarding fields. Electron tubes in industry promise a whole new World of Electronics. I. C. S. has a variety of Radio Courses and a great new standard Electronics Course. Write for booklet, pick your Course.

INTERNATIONAL CORRESPONDENCE SCHOOLS  
BOX 8283-X, SCRANTON 9, PENNA.

Send me full information on the following subject:

Name.....Ade.....

Home Address.....State.....

City.....State.....

Present Position.....Working Hours.....A.M. to.....P.M.

.....



# TELEVISION TECH CORRESPONDENCE COURSE

**WANTED:** Radiomen to take a specialized television course. Instructions begin and end with television. Course has been written for the Radio Serviceman who wishes to learn television repair, and the radio commercial operator who wishes to prepare for this new field. A knowledge of basic radio is assumed.

**PREPARATION:** The authors of a large portion of this course are Edward M. Noll and O. J. Jimerson. Mr. Noll is author of the present television series in Radio News and a former member of the television department of a major radio corporation; Mr. Jimerson, a former senior radar inspector and a former member of the same television staff.

## TELEVISION TECH ENTERPRISES

BOX 94 HATBORO, PA.

### MORE SMASH BUYS at National Radio Distributors

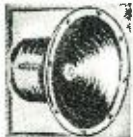

**SPEAKERS at Your Price**  
10" PM 12 Watts Output, Extra Heavy Slug.....\$4.95  
in lots of ten or more.....\$4.35  
12" PM 15 Watts Output, Extra Heavy Slug.....\$7.39  
in lots of eight or more.....\$6.35

**RESISTANCE LINE CORDS**  
135 ohm, 180 ohm, 220 ohm, 290 ohm, 160 ohm, 200 ohm, 250 ohm and 330 ohm.  
Each.....47c n Lots of 10.....45c ea.  
535 ohm } Eac: 65c 2/c AC-DC Serv. Cord  
560 ohm } and plug.....22c

**SPECIAL.** Ant. and R.F. Coil for use with .000365 Variable Condensers. Per Set.....59c

**CONDENSER KIT (By-Pass)**  
Consists of 100 condensers (all 600 Volt) in the following sizes: .001, .002, .006, .01, .02, .03, .05, .1 Mfd. Per Kit.....\$5.95

**RADIO KNOB KIT**  
Contains 50 assorted styles set screw knobs for 1/4" shaft. A beautiful assortment of the most popular styles in present use. Per Kit.....\$3.69

**INSULATED RESISTOR KIT**  
Contains 100 most popular sized DELUXE assortment of 1/4, 1/2 and 1 Watt, R.M.A. color coded, some Gold Band. Per Kit.....\$2.75

**AERIAL KITS** (individually boxed) complete, including full instructions.....75c

**SPECIAL.** All sizes by-pass condensers. Up to .05 mfd. (All 600V). Ea. \$0.07 Per 100.....\$5.50 Fully Guaranteed

**RADIO KITS**—4-tube TRF (including Tubes). SPECIAL.....\$10.75  
5-tube SUPERHET (including Tubes).....\$17.95

Write for Our Latest Catalog. Just out!

### National Radio Distributors

140 A. West 42 St., New York 18, N.Y.

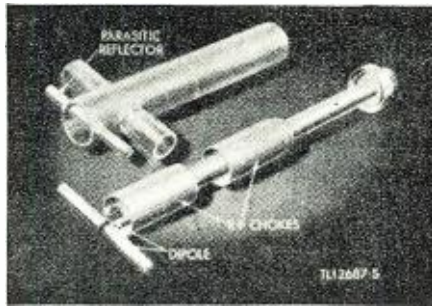

Photograph of the AN/TRC-5 antenna assembly. The outer case has been removed.

ductor would be at ground potential with respect to r.f. and would not radiate properly. The r.f. choke consists of a metal skirt, one-quarter wavelength long, placed about the coaxial cable feed.

Electrically, the choke is merely a quarter wavelength line shorted at the lower end and open at the upper end. The short circuit is reflected at the open end as a high impedance, and since the skirt is at r.f. ground potential, the left-hand dipole will be isolated from ground, thereby forming a balanced input. The bottom choke functions in a similar manner and presents a high impedance to ground at a point on the coaxial cable outer conductor just below the top skirt. This high impedance prevents the leakage of r.f. currents down the outer shield of the coaxial cable. The dipole is encased in polystyrene and the skirts are encased in lucite to prevent changes in electrical characteristics due to moisture, etc. No adjustments of any kind are required for satisfactory performance over the frequency range of 1350 to 1500 mc.

A parasitic reflecting element is mounted directly in front of the dipole and is spaced so that it will reradiate in the proper phase to reinforce the signal radiated back toward the parabolic reflector. In this way there is very little direct radiation from the antenna, the main part of the radiation being reflected as a highly directional beam by the parabolic reflector.

The antenna assembly is mounted on a parabolic reflector with the dipole located at the focal point of the paraboloid. The paraboloid has the property of reflecting as a beam all rays striking it from a source located at its focal point. Moreover, the distance along all reflected rays measured from the source to a plane held squarely in front of the paraboloid are equal, regardless of what part of the curved reflecting surface they strike. The parabolic reflector or paraboloid therefore serves to concentrate the electromagnetic wave from the transmitter into a narrow beam, all portions of which arrive in phase at the distant receiver. The radio beam is similar to a searchlight and must be pointed accurately at the distant receiver.

The receiver is a 15-tube superheterodyne, tunable over a frequency range of 1350 to 1500 mc. R.f. energy picked up by the receiving antenna is

## EASY TO LEARN CODE

It is easy to learn or increase speed with an Instructograph Code Teacher. Affords the quickest and most practical method yet developed. For beginners or advanced students. Available tapes from beginner's alphabet to typical messages on all subjects. Speed range 5 to 40 WPM. Always ready—no QRM.



**ENDORSED BY THOUSANDS!**

The Instructograph Code Teacher literally takes the place of an operator-instructor and enables anyone to learn and master code without further assistance. Thousands of successful operators have "acquired the code" with the Instructograph System. Write today for convenient rental and purchase plans.

## INSTRUCTOGRAPH COMPANY

4709 SHERIDAN ROAD, CHICAGO 40, ILLINOIS

## TEST EQUIPMENT

**SHIPPED FROM STOCK!**

SIMPSON 260-volt-ohm-milliammeter. \$33.25  
SIMPSON 215-volt-ohm-milliammeter. 17.25  
TRIPLETT 2413-tube tester..... 45.00  
TRIPLETT 666-H-volt-ohm-milliammeter..... 16.00  
RADIO CITY 705-signal generator.... 49.50  
RADIO CITY 805-tube and set tester.... 89.50  
SUPERIOR 400-multimeter..... 52.50  
SUPERIOR CA-11-signal tracer..... 18.75  
DuMONT 164-E-3" oscilloscope..... 105.00  
Also, many, many other available.

**WE ALSO STOCK AMPLIFIERS!**

Amplifiers and complete sound systems available from \$29.69 up. Write to us on your specific needs.

Orders shipped C.O.D. upon receipt of 25% deposit

**SCENIC RADIO & ELECTRONICS CO.**  
53 Park Place • New York 7, N. Y.



### Photo Electric Unit

For numerous control applications such as burglar alarms, industrial safety controls, automatic counters and in conjunction with a chime or bell to announce entrance of people in stores and offices. For AC.

Complete with all tubes and SPDT control relay. Net.....\$9.45

**ADSON RADIO CO.**  
221 FULTON ST., NEW YORK 7, N. Y.

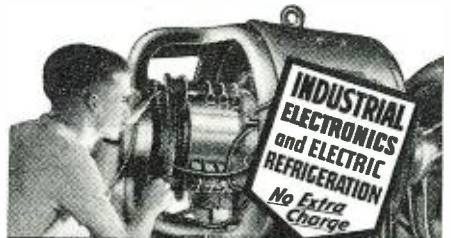

**TRAIN FOR  
A GOOD PAYING JOB IN  
ELECTRICITY  
WITH A REAL PEACE-TIME FUTURE!**

*Pay Tuition After Graduation*

Practical training on real electrical equipment, "Learn-by-Doing" at Coyne—12 weeks' shop training. No previous experience or advanced education needed. Prepare for a good job in vital work—protect your future. EXTRA INDUSTRIAL-ELECTRONICS and ELECTRIC REFRIGERATION TRAINING—NO EXTRA CHARGE!  
"Part-Time Employment Plan" and "Job After Graduation Service" offered. Send coupon now for my Big Free Book. We are equipped to train those who qualify under G. I. Bill. We also have facilities for men with physical disabilities whether due to war or other causes.

H. C. LEWIS, Pres., COYNE ELECTRICAL SCHOOL  
500 S. Paulina St. Dep. 16-81 Chicago 12, Illinois

**MAIL THIS COUPON TODAY!**  
H. C. LEWIS, Pres., Coyne Electrical School  
500 S. Paulina St., Dept. 16-81, Chicago 12, Ill.

Send Big Free Book and details.  Send G. I. Bulletin  Send Physical Disability Details

Name.....  
Street.....  
City..... State.....



fed through a coaxial cable to the receiver input connector, where it is coupled to a crystal detector. In the crystal detector stage the r.f. signal is beat against an oscillator frequency from an oscillator which is 16 mc. lower or higher than the received signal. The resulting 16-mc. intermediate frequency from the crystal detector is then fed through seven stages of i.f. amplification. The output of the seventh i.f. stage is then coupled to the detector. The positive-going output pulses from the cathode of the detector are fed through three cascade two-stage pulse limiters. These limiter stages function to remove noise and other objectionable amplitude-modulated signals, resulting in a signal of constant amplitude. The limited pulses are then fed through a coupling stage and pulse output stage to the receiving multiplex. The alarm control stage is biased past cut-off by the video pulses, causing an alarm relay to be de-energized and alarm buzzer to remain inoperative. Loss of signal causes the alarm buzzer to sound. A rectifier tube provides +270 volts and -10 volts d.c. for operation of the receiver circuits.

Well, there are the new sets. But what advantages do they offer? Here is the Signal Corps' answer:

1. The same facilities as wire circuits, with the same or better quality.
2. Reduction of installation time from weeks or months to hours or days.

3. Reduction in weight and volume of equipment, for example, from 94,000 pounds to 17,000 pounds for a 100-mile system, 2700 cu. ft. to 700 cu. ft.

4. Reduction of repeater stations in some cases from four to one every 100 miles.

5. Reduction of sabotage in hostile territory — improvement of military security.

-30-

### Studio to Master Control

(Continued from page 49)

Equipment for a remote broadcast depends on the size and nature of program to be aired, area of operations, and, what is most important, whether or not the actual broadcasting will be done from a fixed location or while in transit.

Special type microphones of rugged construction are used in conjunction with battery powered amplifiers exclusively designed for field operations. In addition to this standardized sequence, a five minute transit nemo may require the use of a compact high quality short-wave transmitter, communications type receiver, impedance matching units, headphones, spare tubes, batteries, and necessary maintenance equipment.

In spite of all precautions taken to insure continuous operation of remote equipment, it is, however, an unwritten law amongst broadcasters to route

any and all remote shows through a stand-by studio nearest the point of origination. Then in the event of trouble, the stand-by studio fills with appropriate music until normal transmission can once again be established with the remote point.

Field engineers have broadcast from swift bombers high in the clouds, from spray-swept decks of speeding PT craft, and lately one intrepid paratrooper covered his own descent using light weight para-talkie gear!

The war has already given birth to a new species of engineer, namely, the communications-correspondent. Men such as these have risked their lives to make recordings of actual V bomb attacks, spot-broadcast real battle engagements, and hit the beach with the first wave, armed only with tape recorder and microphone.

True to his creed, "Whatever it is, wherever it is, we'll air it," the field engineer assuredly occupies an extremely important role in introducing the vast, invisible radio audience to circumstances and events closely affecting their future and destiny.

In broadcasting, as well as associated industries, probably the least romantic yet vitally important job is that of maintenance engineer. Upon his tolerant shoulders rests the sole responsibility of servicing, checking, and maintaining a wide variety of complicated broadcast equipment.

For him the day may begin with the delicate job of replacing a new ribbon

# Fahnestock Clips

## RADIO'S GREATEST CONVENIENCE

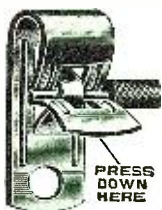

### FAHNESTOCK SPRING BINDING POST GRIPS THE WIRE BY THE ACTION OF A SPRING

Grips the wire with just the right pressure for good electrical contact without least injury to the wire. NO TOOLS REQUIRED TO MAKE THE CONNECTION. Simply press down on the spring, insert the wire and let go. The end of the wire does not have to be bent or twisted, consequently the connection can be made or unmade as often as desired, without the end of the wire breaking off.

Positive contact; cannot jar loose.

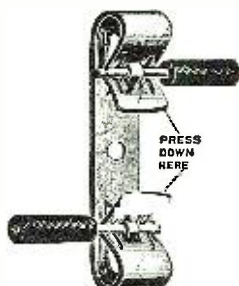
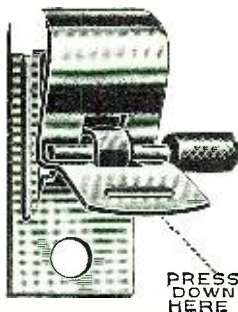

### FAHNESTOCK ELECTRIC COMPANY, Inc.

46-44 ELEVENTH STREET  
LONG ISLAND CITY 1, N. Y.

Please send me at once, Descriptive Literature, Prices and Delivery Schedule on

### FAHNESTOCK CLIPS

Name .....  
Address .....  
City..... State.....



## Unusual Buy Cathode-Ray Tubes

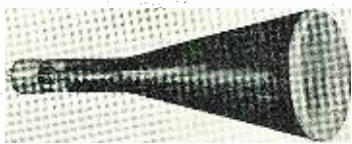

New, Factory sealed, for  
**TELEVISION & OSCILLOSCOPES**  
RCA 5BP4 price.....\$18.00  
N-U 3AP1 price.....\$ 9.00  
Other CR Tubes 3" to 12"

### Amphenol Coaxial Cables

Polystyrene beaded & Polyethylene solid dielectric, for low losses and freedom from interference.  
Type 21B-290-7/26-XXV, 72 Ohm., List price \$0.85, your price \$0.25 p. ft. Many other types. Ask for list.

### TELEVISION PARTS

RCA Deflection yokes compl. with hardware and cable.....\$19.50  
RCA High and Low Voltage complete in one unit Television power supplies, oversize unit.....\$90.00  
AEROVOX Type 3009 Capacitor .5 MFD, 3000 Volt Working.....\$ 2.40  
DUMONT Wide Band Oscilloscope Type 241.....\$458.00  
All types of ceramic, mica and oil CAPACITORS. Many other television parts.  
Send 50 cents coin/stamps for complete list including diagrams for TELEVISION sets RCA, GE, DUMONT, ANDREA. Free with order \$5.00 or more.  
RCA Parts and Equipment Distributors  
WORLD'S FIRST SPECIALIZED HOUSE IN TELEVISION  
ELECTRONICS SERVICE & SUPPLY  
262 West 40th Street, New York 18, N. Y.

in a ribbon-type microphone. Perhaps an hour or two later master control may call on the emergency phone. Within a few seconds the maintenance engineer, tool bag streaming behind, is whizzing down the hallway anxious to knock some sense into a few stubborn relays. The close of day may find him busily engaged taking noise and distortion measurements on some newly purchased monitor amplifiers.

With the exception of maintenance, very few engineers, even those of many years seniority, are entirely familiar with the back of an ordinary studio control room rack. There, between jack field and terminal block, in an intricate pattern of colored wire run innumerable connections linking microphone to pre-amp, pre-amp to mike key, and so on until the final termination line to MC is reached. As if to make the job-repair more difficult, fixed pads, attenuators, and bridging coils appear at most unexpected places. It is, therefore, no wonder that the indefatigable maintenance man sometimes breathes a prayer of gratitude to the gods of like impedances.

Aside from being on emergency duty twenty-four hours a day, maintenance engineers adhere to a fixed schedule of procedure which includes a systematic check on all technical facilities essential to operations. On the so-called dog watch, which occupies the late evening and early morning hours, complete audio quality and continuity checks are given to both studios and master control. Maximum efficiency is thereby achieved during the following day's operations.

Psychologists have proved that men who like to know how, why, and wherefore, usually are the best mechanics in any technical field. Such persons are alive with the desire to comprehend and, if possible, to improve the object of their interests. However, some engineers who seek to augment a decided theoretical background with additional practical experience at times request a transfer to the maintenance division. In certain cases at least two years experience in this field is a must even before considering an applicant for employment.

Master Control in the neophyte engineer's eyes is the Valhalla of the elite, the dwelling place of absolute personal efficiency, integrity, and knowledge. Actually, this seeming image of perfection is the result of close co-operation, double checking and minute observance to even the slightest details.

The human brain with its complex pattern of nerves has often been compared with the central master control of a major network. Programs coming in from many sources are here integrated, checked, and channelled off into lines feeding transmitter, smaller master controls of outlying stations, recording companies, and other portions of the system's vast network.

Discounting feeds for recording purposes, sometimes as many as six different air programs will be passing



## SALESMEN FOR CITY AND COUNTY Nationally Known Manufacturer

Build up a business of your own with Nationally Advertised Products bearing Underwriters' label. Sell to schools, factories, service stations, warehouses, hotels, restaurants, public institutions, truck and bus companies, grain elevators, house trailers, autos, farms, homes, etc. Capable man can earn real money. Established in 1916. Write letter with details, age, experience, etc.

THE FYR-FYTER CO.,  
Dept. 22-13 Dayton 1, Ohio

## KING OF ELECTRIC SWITCHES VERSATILE SWITCH OF A THOUSAND USES MILLIONS IN POSTWAR APPLICATIONS



Floodlights your porch when the door is opened — sounds alarm when window is opened — signals arrival of mail — controls heating of furnace — filling of water tank. —these and many other services are performed by this versatile switch. Shipped with instruction sheet showing numerous illustrated uses for this device at the low price of \$1.00 postpaid.

KING PRODUCTS COMPANY  
BATAVIA 4, ILLINOIS

## PEN-OSCIL-LITE

Extremely convenient test oscillator for all radio servicing alignment. Small as a pen. Self powered. Range from 700 cycles audio to over 500 megacycles u.h.f. Output from zero to 155 v. Used by Signal Corps. Write for information.

GENERAL TEST EQUIPMENT CO.  
38 Argyle Buffalo 9, N. Y.

## RADIO

RADIO Technician and Radio Communications courses. Register now for new classes starting first MONDAY of each month. Day and Evening Classes.

AMERICAN RADIO INSTITUTE  
101 West 63d St., New York 23, N. Y.  
Approved under GI Bill of Rights.

## GRABREE'S WHOLESALE RADIO

2608 Ross Ave.

DALLAS 1 TEXAS

## ★ ★ RADIO ★ ★ COMMUNICATIONS

... on land ... on sea ... in the air  
RADIOTELEPHONY — RADIOTELEGRAPHY

Practical courses conform to FCC technical standards. Free tuition. Free bulletin.  
WESTERN RADIO COMMUNICATIONS INSTITUTE  
Specialists in Radio Communications  
106 W. Third St. (A), Los Angeles 13, Calif.

## Specify SAUERISEN ACIDPROOF CEMENTS—COMPOUNDS FOR

Tanks, Sewers, Stacks, Floors  
Technical cements for all purposes.

Send sketches or samples  
Sauerisen Cements Company · Pittsburgh 15, Penna.

FOR

*Perfection*

IN PERFORMANCE  
AND CLARITY OF TONE



USE—  
PERFECTION Brand  
SPEAKERS  
embodying  
ALNICO 5

PERFECTION  
ELECTRIC COMPANY  
829 SOUTH STATE STREET  
CHICAGO 5, ILLINOIS



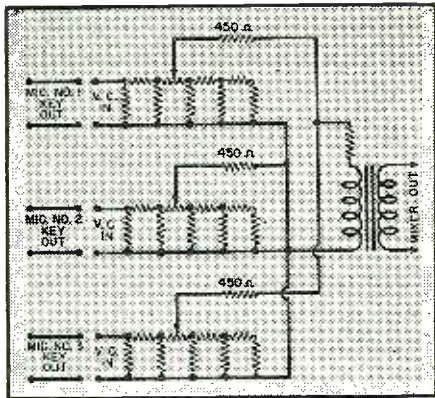

Fig. 3. Ladder type mixer.

through the hands of the MC operator, to points both near and far. It is easy to understand, therefore, that large sums of money are involved and the slightest error on the part of the man at the operating board can easily disrupt the entire nationwide network.

Line failures, the bugaboo of early broadcasting, are today quickly isolated and tracked down by telephone company and MC engineers working together. Should any piece of MC equipment fail or go bad while on the air, it must immediately be patched out manually and an emergency piece substituted instead; for time is money and any time lost is money lost, not to say anything of operating prestige involved.

To sustain uniform transmission and, at the same time, uncover any losses on incoming as well as outgoing lines, a close check is kept on the standard level of +8 VU. Programs are also monitored for line noises, distortion, and hum. Should these occur they are included in the daily operational report together with any technical errors or operational difficulties.

Audio frequency runs covering the range from 30 c.p.s. to 10,000 c.p.s. are given to both emergency and regular transmitter lines by the night crew. Application of this procedure is also observed on both remote and recording lines.

Practically every switching action performed on the MC board is pre-conceived, not only in the light of what is supposed to happen when a certain relay is actuated but also what should be done in case this relay fails to operate. On more complex switchovers, the case of the relay not operating is just a minor consideration to be taken into account.

Ramifications such as these are the MC engineer's daily subsistence. In time he even develops an uncanny ability to see the major portions of the entire network operating with a machine-like precision.

For a likely impression of master control in operation, imagine for a moment five good sized loudspeakers mounted overhead with each one of them carrying a different program. At once the shrieking of a soprano somewhere on the west coast will

January, 1946

## NEW TENTH EDITION

... out in February

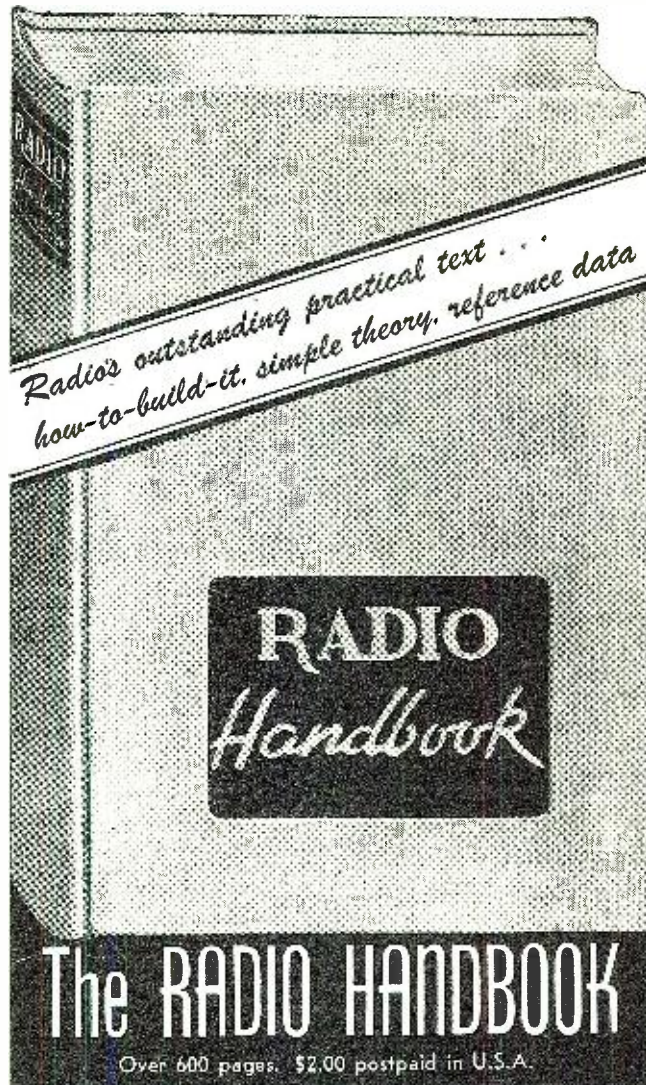

Radio's outstanding practical text; the how-to-build-it book for the practical man. The leader in the field for many years. Written especially for those without technical or mathematical training; all theory sections are in the simplest possible language.

New enlarged tenth edition has many improvements, especially expanded u.h.f. chapters and complete postwar tube tables.

Over 700 pages; clothbound, gold-stamped. Hundreds of diagrams and large photographs. From your favorite radio parts dealer, or direct from us, postpaid.

**EDITORS AND ENGINEERS**

1420 North Highland Avenue, Los Angeles 28, California

The advertisement features a stack of 'Job Card' forms. The text reads: 'NEW! 4-in-1 Job Card'. Below this, it says 'Designed for Service Dealers'. A list of features includes: '1. Radio - Appliance Tag', '2. Customer Claim Check', '3. Guarantee', and '4. Job Flow Card'. At the bottom, it says 'SAMPLE AND PRICES ON REQUEST' and 'Radio Press HOBGANTOWN WEST VIRGINIA'.

## Electrical TRAINING RADIO & ELECTRONICS

Fundamentals of Industrial Electrical Engineering

8 months' intensive residence course prepares for technician, engineering aides in communications, power, business machines, sales, service.

Theory and extensive laboratory practice, drafting. Graduates hold responsible technical and engineering positions. Approved for veterans. Enter Feb. 25, July 8, 53rd yr. Catalog.

**BL SS** 201 Takoma Avenue Washington 12, D.C.  
ELECTRICAL SCHOOL





**HOPP**  
**Plastic**  
**RADIO DIALS**  
 DIAL WINDOWS, NAME PLATES, SCALES,  
 GAUGES, CHARTS, CALCULATORS, ETC.

RONIC CORPORATION OF AMERICA

PLASTIC RADIO DIALS combine the beauty of radiant color with the utility of perfect light transmission.

The possibilities of design, size, shape and color combination are limitless.

Whether your problem is dials, or any of hundreds of allied applications, let Hopp artists and engineers "sit in" on your designing problem.

Send us your blueprints or samples for quotation.

**THE HOPP PRESS, INC.**  
 PRINTING - FABRICATING - FORMING  
 460 W. 34th STREET, N. Y. C.  
 ESTABLISHED 1893

**RADOLEK**  
 Radio-Electronic Service Parts

Large stocks assure the finest and most complete selections of all available items at lowest prevailing prices. Thousands of active buyers depend on us for their entire Radio repair and replacement requirements. Because we understand service problems, every order is expedited for delivery in double quick time. Everything we do is planned for convenience and satisfaction to our customers. You will find it profitable to make Radalek your buying headquarters.

**FREE BUYING GUIDES**

Because of existing conditions we keep our customers right up to the minute on available merchandise by releasing supplements frequently instead of sending our regular Big Profit Guide once a year. Send the coupon now to get these Free Buying Guide Supplements as they are issued.

**FREE!**

**FAST SERVICE!**  
 RADOLEK CO., Dept. B-110  
 601 W. Randolph St., Chicago 6, Ill.

Please send FREE Buying Guide Supplements

NAME \_\_\_\_\_  
 ADDRESS \_\_\_\_\_

**ORDER FROM RADOLEK**

seemingly contest with the dull thud-thud of a hot New York jive band. From another source may come bursts of staccato laughter interspersed with loud hand clapping in the vicinity of +20 VU or thereabouts. By now the symphonic show is going full blast with one of Beethoven's protestations against life while the dull orator from studio X drones on and on.

In between the telephone jangles discordantly demanding your attention, advice, and good humor; if there is any left by now. All in all though the MC engineer learns to take these things in his stride, maintaining however a quality of vigilance and almost instantaneous reaction in case something should go amiss.

After a somewhat strenuous 8 hour day, one would naturally expect the MC engineer to be relaxing on the porch with the evening newspaper. Instead he is more likely to be found puttering around the basement, putting the final touches on the new amplifier which he swears is flat  $\pm 1$  db. from 10 to 18,000 c.p.s.

-30-

**Radio Operated Airplane**  
*(Continued from page 29)*

remote-control box on the ground and are employed in guiding the plane, which was used during the war as a flying target for anti-aircraft gunners. The fifth radio frequency holds the parachute in its true position for an ultimate landing of the plane. This fifth frequency is automatically in operating position while the other four frequencies are being used. When the pilotless flight is terminated, a switch at the control box on the ground cuts off the audio-frequency tones and thus releases the trapdoor of the parachute, also stopping the engine.

The launching catapult of this dwarfed airplane functions on the principle of a slingshot. It is composed of a metal-tubed length with top rails, and a group of helical springs. As the miniature airplane departs from the firing end of the catapult, the assembly is arrested by a snubber shock cable and the target plane continues its flight into the air. The 8-horsepower engine generates a staccato noise which is said to blanket the semi-tropical, jungle-like countryside of that vicinity of Florida.

The seven-man ground crew of Lieutenant Eugene M. Applebaugh bide their time as the lieutenant, beside the mobile radio-controlled apparatus on a three-quarter-ton Army truck, maneuvers by radio the catapulted craft into a steep climb and short bank. Only a stone's throw away are teams of anti-aircraft gunners practicing a simulated defense (even in peacetime) against the pseudo-marauder in the threat of this radio-guided airplane target.

The helmeted crews, with quick pre-

**Classified**  
 Rate 20c per word, Minimum, 10 words

**RADIO ENGINEERING**

RADIO Engineering, Broadcasting, Aviation and Police Radio, Servicing, Marine Operating and Electronics taught thoroughly. Expenses low. Write for catalog. Valparaiso Technical Institute. Dept. N, Valparaiso, Ind.

**RADIO EQUIPMENT**

RADIO Service men and experimenters send for our giant radio catalogue. Save dollars. United Radio Co. (100M) Newark, N. J.

**FOR SALE**

RECTIFIERS—Halfwave, 5 Amperes, \$4.50, 2.2 Amperes, \$2.25; 1.5 Amperes, \$1.85. Fullwave, 1 Ampere, \$2.50; 5 Ampere, \$1.85. Maximum 18 volts input. List free. Milton Bursma, Route 5, Grand Rapids, Mich.

BUZZER Code Practice set complete with key, battery and instructions. Sends real wireless signals. Only \$1.65. Two sets \$3.00. Guaranteed Rathert Electric. Dept. N. Cresco. Iowa.

LOWEST Prices. Radio Tubes, parts. Bargain lists 3c. Potter, 1314 McGee, Kansas City 6, Mo.

ARMY Aircraft Surplus! R14 Headphones, \$2.50; throat mikes, \$4.50; hand mikes, \$6.50; telephone cushions, pair, 95c; bushel basket electrical & radio gadgeteer's lot, damaged, used, only \$4.95 shipped express. Aero Instrument Company, Municipal Airport, Houston, Texas.

FREQUENCY meters, vibrating reed type, 50 and 60 cycles, 125 volts, 10 needs. Three inch case, flush mount. New. \$3.50 postpaid. John Isaacs. 2412 W. 156th St., Gardena, Calif.

2 RME 99 RECEIVERS. 450 watt transmitter, 5 band, P.A. amplifiers, prices reasonable. C. H. Miller, 2221 Ave. D, Kearney, Nebr.

ELECTRONIC Continuity Tester. Newly designed circuit with radical war developments. Range from 0 ohms to 50 megohms; test condensers; uses 60 cycle A.C.; cost of construction, \$4.00. Circuit design, \$.75. Paul Anthony Laboratories, Chestnut St., Manchester, N. H.

**CORRESPONDENCE COURSES**

USED Correspondence Courses and Educational Books sold or rented. Inexpensive. Money-back guarantee. Write for Free Catalog listing 4000 bargains.—(Courses Bought.)—Lee Mountain. Pisgah, Ala.

CORRESPONDENCE Courses and self-instruction books, slightly used. Sold. Rented. Exchanged. All subjects. Satisfaction guaranteed. Cash paid for used courses. Complete information and 100-page illustrated bargain catalog FREE! Write Nelson Company, Dept. 2-59, Chicago 5.

USED Correspondence courses, Educational and Technical Books, bought, sold, rented. Catalog Free. Educational Exchange, Henagar, Ala.

AMATEUR radio licenses. Complete code and theory preparation for passing amateur radio examinations. Home study and resident courses. American Radio Institute, 101 West 63rd Street, New York City.

**PATENT ATTORNEYS**

RANDOLPH & Beavers: Registered Patent Attorneys, 231 E. Columbian Building, Washington, D. C. In order to Protect your invention and reap the reward that should be yours, Patent your invention without delay, and at the same time have Rights to sell as Manufacturers convert to Civilian Production. Write for information and Record Form Today.

PATENTS SECURED Two valuable booklets sent free. Write immediately. Victor J. Evans & Co., 148-A Merlin Bldg., Washington 6, D. C.

**WANTED**

WANTED—Old issues of Modern Electrics and Electrical Experimenter. Lipani, 157 Leverett St., Boston, Mass.

**MISCELLANEOUS**

EXPORT to Denmark. Leading Danish firm in the radio and electrical industry wants to take over the representation for Denmark of American firms. We are particularly interested in Novelties and Specialties, but also in other products in the above lines. Submit quotations to TO-R Radio A/S, Hovitzvej 11, Copenhagen F, Denmark.

VETERAN, 27, over four years Signal Corps, three as officer. Experience chiefly operations but interested technical radio. Would like position where possible learn radio, advance by study. High I. Q. (147). Louis Haas, 1866 W. 42nd Place, Los Angeles 37, Calif.



# JUKE BOX RECORDS

## LATEST & HARD-TO-GET BACK NUMBERS

Some slightly used and some brand new—Victor, Bluebird, Columbia, Okeh, Decca, Capitol, etc. Such artists as Glenn Miller, Benny Goodman, Harry James, Bing Crosby, Frank Sinatra, Gene Autry, Duke Ellington, Fats Waller, Guy Lombardo, Andrews Sisters, Kate Smith, Ink Spots, Mills Bros., etc.

**BIG PROFITS** Your opportunity to cash in on this new field that is sweeping the country. Specify the type of music that sells best in your territory such as Swing, Sweet Music, Cow-boy, Hill-billy, Polkas, Blues, etc. Your price \$13.90 per 100 records, f.o.b. Chicago, 2% off for cash with order. All shipments made within 48 hours.

CHAS. HOODWIN CO.

4419 Broadway, H-15, Chicago 40, Illinois  
World's Largest Dealers in Used Records



**NEW TINY POCKET SIZE RADIO!**  
Slips in your pocket or purse. Wt. only 3 ozs.! Complete **READY TO PLAY** as shown with self-contained phone for personal use. Beautiful black plastic case. Has a patented fixed Crystal - Slide Tuning Dial! **NO TUBES. BATTERIES, OR ELECTRIC PLUG-IN REQUIRED.** U.S. PAT. 2,117,100. RECEIVES LOCAL BROADCASTS without outside aerial wires.

**GUARANTEED TO WORK** when connected and used according to instructions or your money back. 10-day trial. Can be used in homes, offices, hotels, cabins in bed after hours. (cash, money order, check) and pay postman \$2.99 plus delivery fees on arrival or send \$3.99 for postpaid delivery. **IDEAL GIFT FOR CHILDREN OR ADULTS ALIKE!** Get your **PA-KETTE RADIO** NOW for real enjoyment. Dealers in most cities.

PA-KETTE ELECTRIC CO.  
KEARNEY, NEBRASKA

DEPT. RN-1

## WANTED

Engineer with nationwide sales organization desires radio or electrical products or ideas which can be developed into marketable items. WRITE fully.

BOX 423 c/o RADIO NEWS  
185 N. Wabash Ave. Chicago 4, Ill.

# Learn RADIO-ELECTRONICS-TELEVISION

## 12 WEEKS TRAINING IN COYNE SHOPS WHERE YOU "LEARN-BY-DOING"

*H. C. Lewis*

Trained Radio-Electronics men needed now. They will be needed too when the war is over. Tremendous expansion in Radio, Electronics, Frequency Modulation and Television predicted—a world of new opportunities. Get Radio Training in the Coyne Shops in Chicago now, and BE READY.

*All Finance Your Training*

If you are short of money, you can start now and pay most of your tuition after you graduate. Many earn while learning. Free Lifetime Employment Service to graduates. **EXTRA TRAINING IN INDUSTRIAL ELECTRONICS and Electric Refrigeration—no extra cost.**

**FREE BOOK**  
Whether you're 16 or up to 40, get the facts. Big illustrated book tells about your future in Radio-Electronics-Television. Mail coupon today. We also have facilities for men with physical disabilities whether due to war or other causes. Check coupon for details.

**VETERANS**  
Coyne is equipped to train those who qualify for training under the G. I. Bill of Rights. Check coupon.

H. C. LEWIS, Pres., RADIO-ELECTRONICS DIVISION  
COYNE ELECTRIC SCHOOL  
500 S. Paulina St., Dept. 16-1A, Chicago 12, Illinois

Send me FREE BOOK ON COYNE RADIO-ELECTRONICS TRAINING and details of "Pay-After-Graduation" Plan.  Send physical disability details.  Send special G. I. Bulletin.

NAME \_\_\_\_\_  
ADDRESS \_\_\_\_\_  
CITY \_\_\_\_\_ STATE \_\_\_\_\_

cision, zero in on the flying target and go through a rapid routine of load, fire, and reload as the control men continue to line up the elusive target in their guns' sights. The radio-controlled plane, at a pace of 125 miles an hour, dives and banks in evasive endeavors to frustrate the anti-aircraft gunners. This shuffling or maneuvering of the target demonstrates one of the significant benefits of this new type of radio-guided target over the outmoded former system whereby planes towed targets and had to keep on a constant course with their target's dragging sleeves. Once the practice run over the guns is completed, Lieutenant Applebaugh flips another switch on his remote radio-controlled apparatus, a trapdoor on the topside of the small airplane pops open, and the motor begins to sputter and die. From the trapdoor, there emerges a slender mass of silk—a parachute—and in its embrace the model airplane begins its slow but comfortable descent to earth.

The 12-foot wingspread has a counterpart in an 8-foot fuselage of steel tubing covered with canvas. Within this body of the plane are contained the engine, generator, battery, radio receiving apparatus, and the landing parachute under the topside hatch. Late models have displaced the antiquated landing gear with reinforced shock-absorbing keel. The flying target can be set up and launched in a jiffy, with as little open space as 100 yards.

Pellets of atomic energy, with radio in the pilot's seat, may be the source of power for civilian airplanes of the future. Or, the *electronic airplane* (a descriptive term first used by this writer) may take off, be guided, landed, and even powered by electronic waves. Already an automobile is being powered by electronic energy. The radio-operated airplane, however, in its present stage, may be seen at many civilian flying fields first as a novelty to focus attention on the Air Age; then, in later developments, as a flying machine without a human pilot aboard but guided from the ground by radio and carrying passengers on sightseeing tours in the vicinity of our large cities or around such sightseeing objectives as Grand Canyon.

-30-

### Our Apology

That nice Railway Radio gear on our November cover was designed and made by Motorola.

### Photo Credits

Page	Credit
25, 26, 27, 28, 94, 154	U. S. Army Signal Corps
29	U. S. Army Air Forces
30, 31	CBC
33, 110	General Radio Co.
34, 112	Millen Mfg. Co.
38	Robinson-Houchin Optical Co.
44	Superior Instruments Co.
47, 48, 49	CBS
64, 141	BBC
134	General Electric Co.

# Better ATLAS SOUND Equipment Ready for YOU

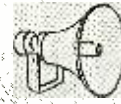

## DOUBLE REENTRANT PROJECTOR

Many sizes. From 15 in. air column to 6 foot air column.



## 360 RADIAL CHANDELIER PROJECTORS

Double Reentrant. For driver units. 3 and 4 foot air column lengths.



## DRIVER UNITS

Various Power Handling Capacities. Newest types of Indestructible Phenolic Diaphragms.



Miniature Type Reentrant Projectors—Booster Speakers.

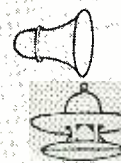

Cone Type Parabolics and Chandelier Baffles for all size cone speakers.



## MICROPHONE SUPPORT STANDS

20 types and sizes. All Fittings, Adaptors and Accessories. Floor Stands, Desk Stands, Banquet Stands, Boom Stands.

Wooden and Metal Cone Speaker Enclosures, Baffles, Carrying Cases, Loud Speaker Support Stands and Brackets.

# ATLAS SOUND CORPORATION

1447 39th Street  
BROOKLYN, N. Y.



ADVERTISER	AGENCY	PAGE	ADVERTISER	AGENCY	PAGE
Acme Electric & Mfg. Co., Inc., The	Scheel Advertising Agency	110	Lectrolab Products	Sander Rodkin Advertising Agency	84
Adson Radio Company	Mitchell Advertising Agency	154	Lifetime Sound Equipment Co.	Miller Agency Company	140
Aerovox Corporation	Austin C. Lescarboursa & Staff	161	Lincoln Engineering School	Buchanan Thomas Advertising	120
Aireon Manufacturing Corporation	Graven & Hedrick Advertising	75	Mallory, P. R. & Co., Inc.	Aitkin-Kynett Co.	Third Cover
Alexander Hamilton Institute	Ralph H. Jones Co	151	Marion Electrical Instrument Co.	Shappe-Wilkes, Inc.	93
Alliance Manufacturing Company	Foster & Davies, Inc.	113	Meck, John Industries, Inc.	Fensholt Company, The	Second Cover
Allied Radio Corporation	Henry H. Teplitz	9	Melville Radio Institute	Seidel Advertising Agency	150
Amalgamated Radio Television Corp.	Shappe-Wilkes, Inc.	145	Miles Reproducer Co., Inc.	Altomar Advertising Agency	120
American Phenolic Corporation	Evans Associates	71	Millen, James Mfg. Co.	James Millen, Inc.	12
American Radio Institute	Sternfield-Godley, Inc.	156	Milo Radio & Television	Burke & Wayburn Advertising	114
American Television Institute	Firestone Advertising Agency	143	Murdoch, Wm. J. Company	John A. Smith & Staff	66
American Television & Radio Co.	Evans Associates	143	Murray Hill Books, Inc.	Harry P. Bridge Advertising Company	80, 81
Arrow Radio Company	Firestone Advertising Agency	143	McElroy Mfg. Corp.	Shappe-Wilkes, Inc.	123
Ashbach, Leonard Company	Lieber Advertising Company	124	McGraw-Hill Book Company	Shappe-Wilkes, Inc.	132
Astatic Corporation, The	Wearstler Advertising, Inc.	139	McMurdo Silver Company	Stentor Company	153
Atlas Sound Corporation	Burke & Wayburn Advertising	159	National Company	Graydon Smith Advertising	162
Audak Company	Hart Lehman	8	National Electronic Supply	MacDonald-Cook Company	100
Audel Publishers	Grant & Wadsworth, Inc.	138	National Radio Distributors	Burke & Wayburn Advertising	154
Baker-Phillips Co.	Mitchell Advertising Agency	84	National Radio Institute	Vansant, Dugdale & Co., Inc.	3
Bell Telephone Laboratories	N. W. Ayer & Son	91	National Schools	Mayers Company	20, 21
Eliss Electrical School	N. W. Ayer & Son	157	National Union Radio Corporation	Hutchins Advertising Company	61
Breeze Corporations Inc.	Burke Dowling Adams	105	Newark Electric Co., Inc.	Charles Brunelle	109
Bud Radio Co.	Allied Advertising Agency	102	Newcomb Audio Products Co.	Gail Hall Advertising	96
Buffalo Radio Supply	International Advertising Agency	120	Ohmite Manufacturing Co.	Henry H. Teplitz	59
Burlington Instrument Company	Weston-Barnett, Inc.	70	Olson Radio Warehouse	Jessop Advertising Agency	152
Burstien-Applebee Company	Frank E. Whalen Advertising	134	Onan, D. W. & Sons	Graves & Associates	112
Candler System Company	Van de Mark Advertising	142	Pa-Kette Radio Company	Arrow Advertising Agency	159
Capitol Radio Engineering Institute	Henry J. Kaufman Advertising	73	Papel Brothers	Schram Company	152
Centralab	Gustav Marx Advertising	115	Perfection Electric Company	Schram Company	150
Clark Radio Equipment Co.	Savage & Talley	143	RCA Institutes, Inc.		112
Clippard Instrument Laboratory	Savage & Talley	94	R. C. & L. F. Hall		86
Collins Radio Company	McCann-Erickson, Inc.	16	R-L Electronic Corp.	R. S. Wittenberg Advertising	148
Concord Radio Corporation	E. H. Brown Advertising	60	Radiart Corporation, The	Kenneth Kolpien	79
Cornell-Dubilier Electric Corp.	Reiss Advertising	107	Radio Corporation of America	J. Walter Thompson Company	22
Coyne Electrical School	Phil Gordon Agency	132	Radio Corporation of America (VICTOR DIV.)	Kenyon & Eckhardt, Inc.	89
Coyne Electrical School	McJunkin Advertising Company	154, 159	Radio Dealers Supply Co.	H. J. Gold	150
Crabtree's Wholesale Radio		156	Radio Distributing Co.	Edward Hamburger Advertising	150
Croname, Inc.		111	Radio Kits	Sidney S. Lovitt Advertising	92
Crystal Research Laboratories	Post & Johnson, Inc.	106	Radio Parts Company	Sidney S. Lovitt Advertising	92
DeForest's Training, Inc.	McDonald-Cook Company	15	Radio Press		157
Diamond Straw Machine Company	Halpern Advertising Agency	130	Radio Supply & Engineering	Karl G. Behr Advertising	116
Drake Electric Works, Inc.	William Hoffman & Associates	144	Radio Wire Television, Inc.	Diamond Seidman Co.	108
Duotone Company, The	Maxon, Inc.	131	Radionic Equipment Company	Hirshon-Garfield, Inc.	98
Eastern Amplifier Corp.	Roberts & Reimers, Inc.	17	Raudlek Company	Turner Advertising Agency	158
Telephone Radio Company	Burton Browne Advertising	87	Rauland Corporation, The	Roy D. Zeff & Associates	101
Editors & Engineers		157	Raytheon Manufacturing Company	Burton Browne Advertising	10, 11
Ecior, Inc.	Henry H. Teplitz	137	Rider, John Publisher, Inc.	Lansford F. King Advertising	69
Electrical Reactance Corporation	Scheel Advertising Agency	152	Roburn Agencies	Reiss Advertising	152
Electronic Service & Supply	Burke & Wayburn Advertising	156	Roehr Distribution Company		150
Fada Radio & Electric Co., Inc.	Sternfield-Godley, Inc.	6	Rowe Industries	Miller Agency Company	144
Fahnestock Electric Company, Inc.		155	Runzel Cord & Wire Company	Duane Wanamaker Advertising	123
Fyr-Fyter Company	Van de Mark Advertising	156	Sauereisen Cements Company	McCarty Company	156
Galvin Mfg. Corporation	Gourfain-Cobb Advertising	119	Scenic Radio & Electronic Co.		154
General Cement Mfg. Co.	Turner Advertising Agency	122	Snyder Mfg. Co.	E. L. Brown Advertising	135
General Electric	Maxon, Inc.	114	Sound Equipment Corp. of Calif.	Beaumont & Hohman, Inc.	62
General Industries Company	Fuller & Smith & Ross, Inc.	82	Sperry Gyroscope Co., Inc.	Charles Dallas Reach	19
General Test Equipment Co.	Suzanne B. Hayman	156	Sprague Products	Harry P. Bridge Company	63
Goodchild Plastics		126	Sprayberry Academy of Radio	Harry P. Bridge Company	7
Greene's Jack, Radio & Television Co.	Burke & Wayburn Advertising	140	Standard Radio & Electronics Products Co.		74
Greenlee Tool Co.	Howard H. Monk & Associates	136	Standard Transformer Corporation	Burnet-Kuhn Advertising	78
Guardian Electric	Kennedy & Co.	65	Stanton Radio Supply		144
Hallcrafters, Inc.	Burton Browne Advertising	5, 77	Stark's	A. L. Addison Advertising	128
Hammarlund Mfg. Co., Inc., The	Roeding & Arnold, Inc.	24	Stevens Walden, Inc.	Howard-Wesson Co.	14
Hanlan Company		124, 153	Superior Instruments Company	Mitchell Advertising Agency	67
Harvey Radio Company	Shappe-Wilkes, Inc.	90	Supreme Instruments Corporation	O'Callaghan Advertising Agency	86
Henry Radio	Burton Browne Advertising	104	Supreme Publications	Henry H. Teplitz	97, 141
Hoodwin, Chas. Co.	J. L. Stewart, Agency	159	Television Tech Enterprises		154
Hopp Press, Inc.	Gallard Advertising Agency	158	Terminal Radio Corporation	Mitchell Advertising Agency	149
Hytron Radio & Electronics Corp.	Henry A. Loudon Advertising	99	Triplet Electrical Instrument Co.	Western Advertising Agency	18, 129
Illinois Condenser Company	Sander Rodkin Advertising Agency	142	Tri-State College	Clem J. Steigmeyer Advertising	126
Instructograph Company	Turner Advertising Agency	154	Turner Company, The	W. D. Lyon Company	143
Instruments Publishing Co.	Cupco Advertising Division	147	Union Radio Corporation	Craig Dennison	148
Insuline Corp. of America	S. R. Leon Company	133	United Screw & Bolt Corporation	Fred W. Mellis	23
International Correspondence School	N. W. Ayer & Son	153	United Transformer Corp.	Shappe-Wilkes, Inc.	Back Cover
Islip Radio Mfg. Corporation	Kotula Company	136	Universal Instrument Company		122
J. F. D. Mfg. Company	Mitchell Advertising Agency	100	Ward Leonard Electric Co.	E. M. Freystadt Associates, Inc.	13
Jensen Industries, Inc.	Allen D. Parsons	106	Ward Products Corporation, The	Burton Browne Advertising	92
Jensen Radio Manufacturing Company	Burton Browne Advertising	85	Weller Manufacturing Company	Beaumont, Heller & Sperling, Inc.	96
Johnson, E. F.	David, Inc.	103	Western Radio Communications Institute		156
Kato Engineering Co.		138	Wholesale Radio Laboratory	Pfeiffer Advertising Agency	118
Kenyon Transformer Co., Inc.	Jasper, Lynch & Fishel, Inc.	117	Wilcox Electric Company, Inc.	R. J. Potts-Calkins & Holden	95
King Products		156	World Wide Communications Equipment		126
Kluge Electronics Company	Wookey & Roman Advertising Agency	121	YMCA Trade & Technical Schools	Cecil Presbrey, Inc.	124
Kurz-Kasch, Inc.	Kircher, Helton & Collett	127	York Radio Distributing Co.		128
Lake Radio Sales Co.	Sander Rodkin Advertising Agency	72			



# 11 CAPACITOR

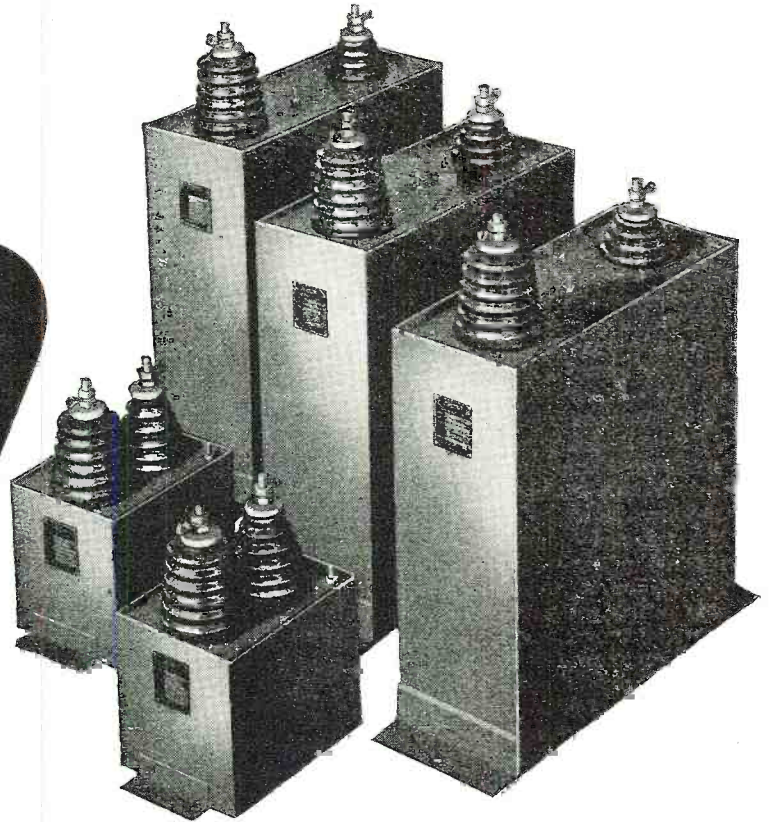

# READNAUGHT'S

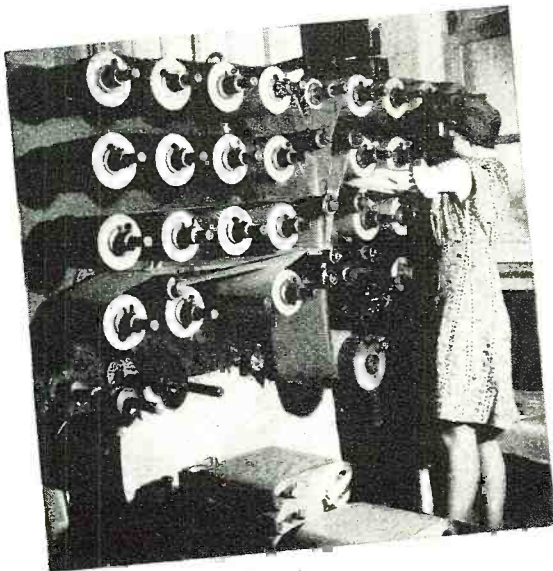

● Interested?  
Write for detailed literature.

● Outstanding production equipment in the hands of Aerovox craftsmen, accounts for these veritable capacitor dreadnaughts. In exacting services such as radio transmitters, heavy-duty electronic equipment, and in the electric power field, these units have won citation after citation for exceptional ruggedness.

Such ruggedness stems from the Aerovox winding facilities second to none. Special winding machines insure that the multi-layered sections are uniformly and accurately wound under critically-controlled tension. Also, a system of impregnation tanks, pumps and control equipment guarantees the necessary drying after vacuum impregnation that is positively unexcelled by any impregnation process anywhere.

Hermetically-sealed welded steel containers; heavy-duty porcelain insulators; cork gaskets and pressure sealing; non-ferrous metal hardware; silver-soldered joints; sturdy mounting means—these are the externals of these capacitor dreadnaughts. Standard listings of Type 20 up to 50,000 v. D.C.W. Capacitances from 0.1 to 10 mfd.



# Capacitors

INDIVIDUALLY TESTED

AEROVOX CORPORATION, NEW BEDFORD, MASS., U. S. A.

SALES OFFICES IN ALL PRINCIPAL CITIES

Export: 13 E. 40 St., New York 16, N. Y. • Cable: 'ARLAB' • In Canada: AEROVOX CANADA LTD., HAMILTON, ONT.



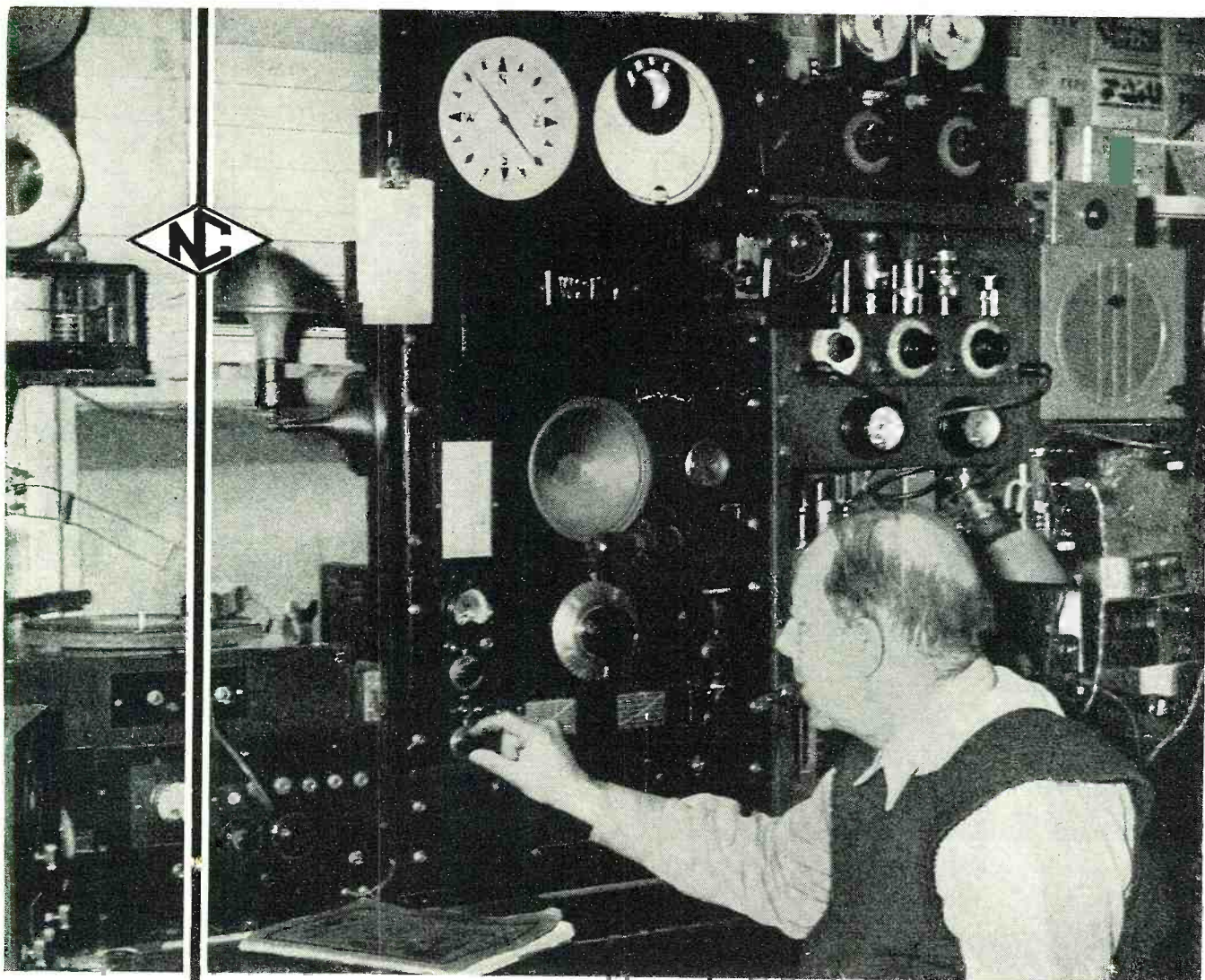

CAPTAIN HORACE L. HALL, U.S. Merchant Marine, retired, at his home in Springfield, L.I., N.Y., made daily recordings of transmissions from Australia, for more than four years, missing but four days. The apparently harmless news broadcasts kept the Australian Government in New York and Washington informed of every phase of the progress of the war, by a pre-arranged code.

The National HRO, used for this remarkable accomplishment is the first ever to have been shipped into the New York area and is over ten years old.

**NATIONAL COMPANY INC., MALDEN, MASS.**

PRINTED IN U.S.A.



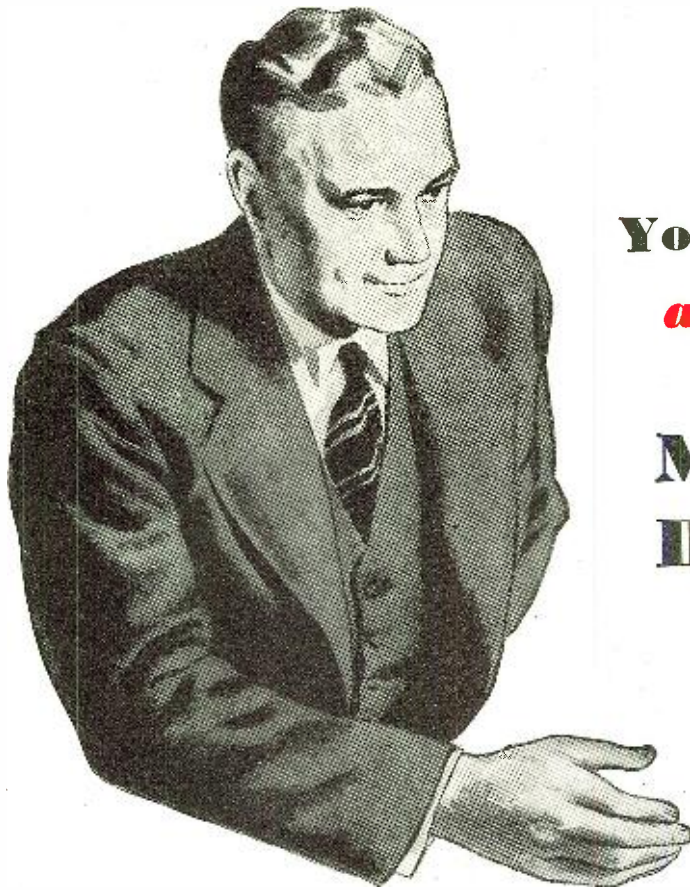

**You'll Get Help**  
*and lots of it*  
**From Your**  
**MALLORY**  
**Distributor**

**T**RUE, your Mallory distributor has the best replacement parts that money can buy. But, equally important, he has a thorough knowledge of the business . . . has the *willingness* to be of service and the *capacity* to give it generously.

Your Mallory distributor will quickly help you locate the parts you want . . . assist you in installing them properly . . . help you in problems of sales, management and personnel training . . . in short, save you a lot of time and money. That's why he's a friend worth cultivating—and a good man to do business with.

## Here is What He Offers

**1**

A complete line of Mallory replacement parts . . . many of them first developed by Mallory research . . . ALL of them guaranteed against premature failure by years of service in the field.

**2**

A program of standardization that meets the maximum number of application needs with the minimum number of parts . . . reduces investment, simplifies replacement, speeds up delivery.

**3**

Efficient service . . . backed by detailed information on prices, parts, catalog numbers . . . promptly applied whether orders are large or small . . . especially effective in meeting emergencies.

**4**

Technical service helps . . . bulletins, booklets, catalogs, letters with complete data on what to use and where to use it . . . special publications on radio fundamentals and new developments.

**5**

A background of personal experience . . . acquired through years of service in radio . . . helpful in solving difficult or unusual problems . . . effective in training dealer personnel.

**6**

Commercial "know how" . . . implemented by sound methods of keeping your business "on the beam" . . . with special attention to promotion devices that help sell your story to the public.

**P. R. MALLORY & CO. Inc.**  
**MALLORY**  
 APPROVED PRECISION PRODUCTS  
 VIBRATORS . . . VIBRACKS® . . . CAPACITORS . . . VOLUME CONTROLS  
 . . . SWITCHES . . . RESISTORS . . . FILTERS . . . RECTIFIERS . . .  
 POWER SUPPLIES . . . ALSO MALLORY TROPICAL DRY BATTERIES,  
 ORIGINALLY DEVELOPED BY MALLORY FOR THE U. S. ARMY.  
Reg. U. S. Pat. Off.  
**P. R. MALLORY & CO., Inc., INDIANAPOLIS 6, INDIANA**



# UNUSUAL DESIGNS AT



## RESONANT TRANSFORMERS

This high voltage application involved a minimum size requirement. For maximum compactness, the final transformer produced has a turns ratio of 115/5,800, but a voltage ratio due to resonance of 115/10,000 V.



## VARIABLE AC SATURATED INDUCTOR

This inductor is part of a voltage sensitive non-linear network. By adjustment of the inductor with a specific capacitor, peak non-linearity can be adjusted over a substantial range in voltage.

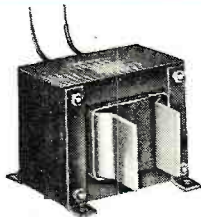

## CONDENSER - PULSE WELDING TRANSFORMER

This transformer is designed for a small precise spot welding set. For this type of application, design factors include High Q and maximum surge power transfer. The transformer shown is the equivalent of 100 VA in size, but handles 1,000 VA pulses.

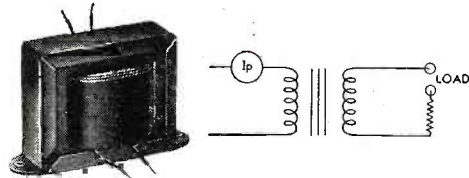

## SPECIAL CONTROL TRANSFORMER

In this odd application, the requirements were that the primary current go down with increase in load current. In actual practice, when normal load is placed on the secondary, the primary current drops 50%.

The UTC application engineering section is available for your problem.

*United Transformer Corp.*

150 VARICK STREET

NEW YORK 13, N. Y.

EXPORT DIVISION: 13 EAST 40th STREET, NEW YORK 16, N. Y.,

CABLES: "ARLAB"

